

EPower controller – extraordinary power control

Improve process performance and save on energy costs with our formidable range of power products. Covering all types of load and voltage, these reliable products offer features such as high performance alarm strategies and advanced diagnostic load fault detection and are supported by our vast experience in all types of power control applications.



The EPower controller uses the newest technologies and innovations to manage your process and reduce your energy costs. On every level it brings you the flexibility you need to best meet your requirements now and in the future.

Let us look after your power control for you with EPower controllers and give you the peace of mind that you have the best for your process – even as it changes.

Eurotherm has a significant R&D capability and a policy of continuous development, improvement and innovation. Investing in EPower controllers will keep options and new developments within your reach as you can upgrade to meet your changing requirements at any point.

EPower controller – total flexibility from precision power control

Easy configuration to save you engineering costs ...

The EPower controller has been designed for easy configuration and modification. The front, integral display has a “QuickStart” facility that leads the user through initial set up in a series of simple steps. To further save engineering this QuickStart code can be specified with your order and the instrument shipped pre-configured.

More advanced configuration can be achieved utilising Eurotherm iTools PC configuration software – which provides the significant assistance of graphical wiring tools and downloadable function blocks to minimise engineering time and cost. Once you have created your application you can easily save and clone your work – either as a back-up or to download to multiple instruments that need the same or similar configuration – keeping your work safe and save repeat engineering costs.

- “QuickStart” for easy commissioning
- Easy save and clone of configuration
- Advanced graphical wiring configuration tools
- Integral front panel operator interface
- Remote display option – can also be used as independent policeman

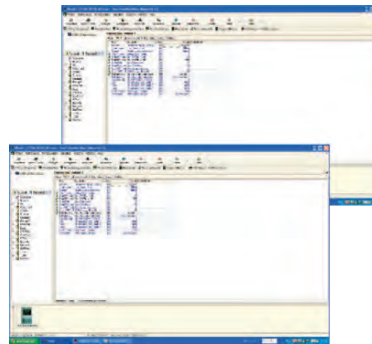

Efficiency through advanced technologies...

EPower controllers have measurement accuracy, functionality and innovation that will deliver you extraordinary power control to help your process, environment and budget.

- Measurement accuracy (better than 0.5%) to help save energy
- Load management for better distribution of energy and to minimise peak energy usage costs
- Reduce energy bills and other costs with a selection of advanced firing modes to best suit your load type:
 - Minimise electrical disturbance
 - Increase lifetime of heater elements



Flexibility

Advanced technologies in harmony with modularity and ease of use to deliver your power control needs.

Efficiency

World class power control with innovative features to minimise your energy costs with exceptional process performance.

Peace of mind

A power controller that will bring you rapid return on investment and can be adapted in the future if your requirements change – one product for all solutions

EPower controller – total flexibility from precision power control

- Easy ordering, configuration and maintenance through modular design
- If your requirements change EPower controller can be easily adapted to your needs
- Minimum spares holding – many options configurable through a common driver module e.g. firing mode, load phases, control etc.
- Up to four power modules provide single and multi-phase control
- Software configurable options to bring you flexibility:

Control Type	Firing Modes	Load Type	Load Configuration	Feedback
Single phase	Phase angle	Standard	Single phase	V2
2 x single phase	Half cycle	Resistive	Star	I2
3 x single phase	Burst firing	Complex	Delta	True power
4 x single phase	Fix modulation period	Resistive	Star with neutral	RMS load voltage
Two phase	Logic mode	Inductive e.g. Transformer	Open Delta	RMS load current
2 x two phase		Short Wave		Open loop
True three phase		Infrared		

You no longer need to be restricted to the options that you order – EPower controller provides you with configurable options and modular hardware to give you the flexibility to match your process now and in the future. Combine this with an instrument that provides easy configuration via the integral display and full graphical configuration via Eurotherm iTools PC configuration tool as standard – you have a power controller that makes life that bit easier.

Success stories commercial benefits

CASE STUDY Typical saving case – power factor improvement with burst firing

- Significant reduction of fixed rate costs
- Reduction of reactive power by almost two thirds
- Reduced annual cost for same power consumption
- Return on investment within 18 months

BUSHING 100 ZONES	30 KW EACH	BUSHING USE	80%
COMPARATIVE ANALYSIS	SCR NORMAL TRANSFORMER	EPOWER LTC 2 TAPS	
Firing mode	Phase angle	Burst firing	
Power factor	0.71	0.92	
Consumption for one month / 720h	720 h	720 h	
Active energy	3,000 kW	3,000 kW	
Reactive energy	3,001 KVAR	1,264 KVAR	
Installed power	4,243 KVA	3,256 KVA	
Cost for one month			
Active power	73,781 €	73,781 €	
Reactive power	30,595 €	12,891 €	
TOTAL	104,376 €	86,672 €	
MONTHLY SAVING		17,704 €	
ANNUAL VARIABLE SAVING		212,450 €	
Installed power fixed rate	512,758 €	393,402 €	
ANNUAL TOTAL SAVING		331,806 €	
PRICE LIST Edf GREEN A5			
EPower/transformers investment + installation	500,000€	ROI	18 months

For the full stories and all our successes go to www.eurotherm.com/success

The EPower controller – the best solution for your power control

With EPower controllers you are not only buying one of the best power controllers in the world, you are supported by a global network of application and control specialists from Eurotherm. While we are a truly global company, we have not forgotten that you still need local support and understanding. Our team will bring you technical expertise along with in depth experience and understanding in numerous application areas – from glass furnaces, to semiconductor manufacture, to the heat treatment of metals and many more. The EPower controller is one product for all your solution needs.

We can provide you with a range of services to suit your needs – from training to commissioning and maintenance contracts for your installation.



Easy Maintenance

- Modular design for easy management of spare parts and quick mean time to repair (MTTR)
- Fast and easy configuration
- Easy wiring, installation and commissioning
- Remote Display option



CASE STUDY New technology to advance heater control and prevent all future overheating

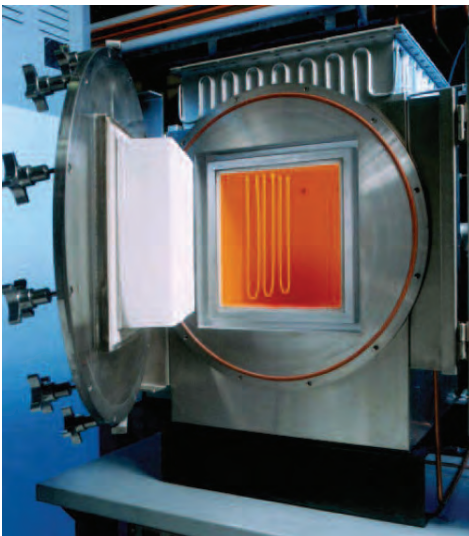

Our client successfully tested a feature of the EPower controller in a new way alongside their world leading brand of (MoSi₂) heaters known as Kanthal Super. A key feature of MOSi₂ heaters is the relationship between impedance and heater temperature.

Customer Challenge

Our customer's goals were to protect their heaters from over temperature, so extending the heater lifetime and to achieve maximum and consistent power.

Solution

- Power controller installed in conjunction with Kanthal Super heaters
- EPower feature used to supply information about heater impedance
- EPower unit controlled by a 2704 over Master Comms

Customer Benefits – using EPower controller

- Significantly helps prevent overheating and ultimately extends lifetime of the heater
- Enables use of minimum margins for power demand while still preventing overheating. This keeps the process time and costs down
- Reports actual number of kWh or mWh used or saved; vital for precise analysis.
- Can ensure the heat treatment process is running at optimum performance at all times
- Predictive Load Management leads to energy savings and possible cost savings

The option that you need ...

A single driver module can support up to four power modules – and hence four independent control loops. Power modules are available in current ratings covering a range from 50A to 630A in compact version and up to 4000A in high current version. The driver module itself supports option boards to give you additional flexibility in your solution:

- **Communications** – RS485 Modbus RTU, Profibus, DeviceNet®, Modbus TCP network protocols, CCLink, EtherNet/IP and ProfiNet
- **Predictive Load Management (PLM)** – A powerful feature to effectively manage your power requirements across multiple machines to save on your energy costs
- **Flexible I/O** – The driver module supports standard I/O and up to three additional I/O boards with analogue inputs, analogue outputs, digital I/O and relay outputs
- **LTC** – The Load Tap changer option for single phase unit applications only, allows for managing multitap transformers, preventing both increased harmonics and the reduction of power factor
- **Energy Counter** – Available over communications and for display on user screens, customers can access up to 5 scalable counters, one per individual phases and a global energy usage counter

The high current version (decentralised) of EPower will be able to manage current ratings from 800A to 4000A and support from 1 to 4 phases.

To make the integration easy, the product is divided in two parts:

- The driver module providing all firing interfaces (MC : Module of Control)
- The power stack(s) cooled by air (800A to 2000A) or water (2000A and 4000A)

All the functionalities of the compact version remain available on the high current version (Quick start configuration, IO boards, PLM, comms capabilities etc.), providing all the benefits of flexibility, efficiency and peace of mind.

Providing a total solution for your application, the MC EPower is supplied with all the necessary accessories (e.g. cable, current transformer, fuses etc.) to ensure optimum performance.

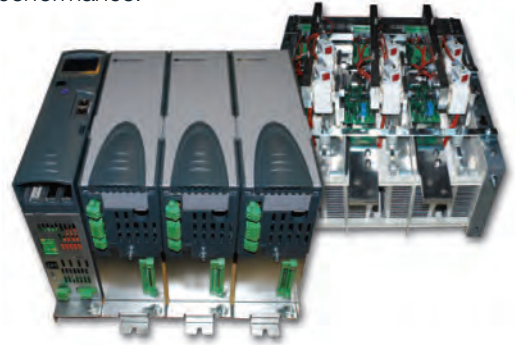

Success stories commercial benefits

CASE STUDY Success for renewable energy wafer technology



An exciting collaboration resulted in outstanding solution for our client, a world leader and pioneer in the design and development of wafer technologies used for the manufacture of solar panels.

Customer Challenge

Our client needed to control immense power with absolutely no loss of stability or accuracy.

Solution

- Power control panel for reactor control
- New Load Tap Changing block application with EPower controller
- All enable manufacture of thin film solar modules and the result is best in class

Customer Benefits

- Unmatched accuracy, stability and quality of power control
- Perfect continuity of power during the transformer tap switches. The Load Tap Changing application vastly improves power factor
- Huge savings expected to exceed future government energy cost saving target
- Reduced energy bills
- Unaffected high quality production
- One of best power solutions in industry today

For the full stories and all our successes go to www.eurotherm.com/success

A product to integrate into a complete solution

EPower controllers have not only been designed to be world-class power controllers that you can rely on, they have been designed to integrate perfectly into a wider control system.

Whatever your system communication preferences are – Modbus RTU, Profibus, DeviceNet, Modbus TCP/IP, CC-Link, EtherNet/IP, ProfiNet – EPower controllers can easily be integrated into your system and send the information you need about your load (current, voltage, alarms etc) so that you stay in control of your process.

Whether you need this latest power controller in a new system or to upgrade an existing system – Eurotherm can help you. Our expertise is not limited to power control – the full benefit of EPower controllers can be optimised using our engineers as experts in creating complete solutions and total, plant-wide DCS.

Throughout our product ranges – controllers, recorders, power controllers, signal conditioning, automation solutions and DCS – you will get expert knowledge, support and world class solutions. We can assist you with small and large applications and offer complete life cycle support and partnership engineering teams – whatever you need, we are there to work with you.

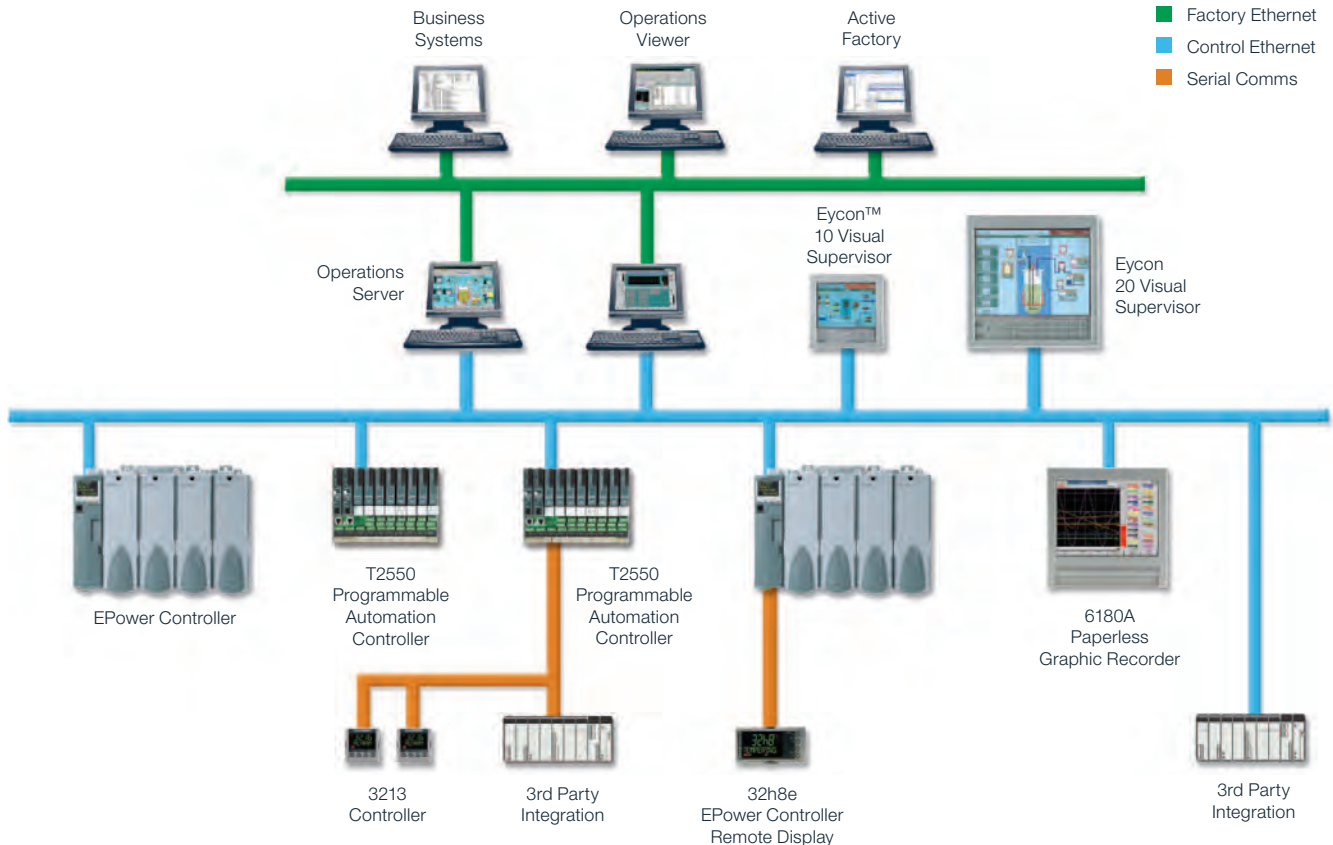

Predictive Load Management – the best innovation for energy management

You can reduce your energy costs across your plant by utilising the Predictive Load Management (patent pending) functionality within the EPower controller. This new feature provides a better distribution of energy across different loads in your installation, by managing the priority and, if necessary, load shedding. The EPower controller prevents overshoot of the nominal power. This will keep you within the limits of your electrical contract for your installation and prevent increases in energy tariffs imposed by your supplier. Unlike other software offering this type of feature, Predictive Load Management from Eurotherm anticipates your energy usage rather than just reacting when you have already exceeded your tariff peak.

Power consumed without "Predictive Load Management"

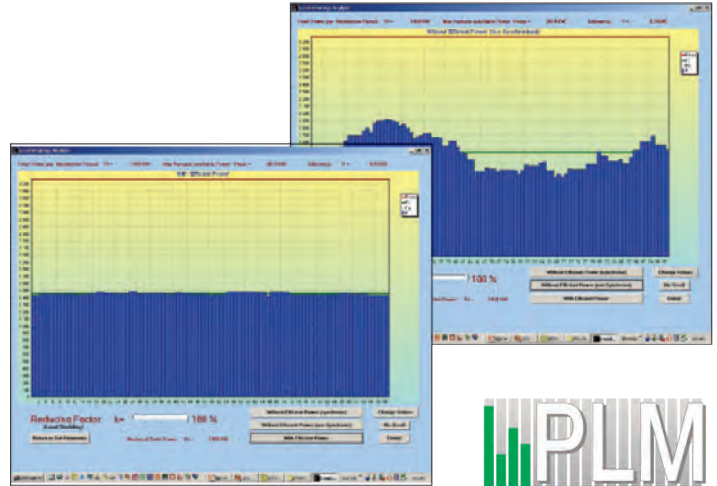

Power consumed with "Predictive Load Management"



Using EPower controllers with Predictive Load Management could well be one of the best value decisions you could make for your plant!

Success stories commercial benefits

CASE STUDY

- Reduced KW Power
- Reduced energy usage
- Reduced annual cost on electricity bill
- Return on investment within 4 months

TOTAL POWER OF FURNACES KW	2900		
AVERAGE POWER DEMAND KW	15000	20 ZONES	145
SUPPLY SUBSCRIPTION KW	3000	FURNACE USE	85%
Type	Hours	Power without PLM	Power with PLM
Peak (TTE)	2309	1,500	1,300
Winter peak hours (HPH)	1762	1,500	1,400
Winter off-peak hours (HCH)	1553	1,500	1,500
Summer peak hours (HPE)	2953	1,500	1,400
Summer off-peak hours (HCE)	2201	1,500	1,500
PRICE LIST Edf GREEN A5	Fix rate calculation	without PLM	with PLM
	Reduced power KW	3,000	1,398
	Fix rate cost €	362,520	168,934
	ANNUAL SAVING €	193,568	193,568
	Variable rate calculation	without PLM	with PLM
	Variable rate cost €	334,317	318,021
	ANNUAL SAVING €	16,296	16,296
	TOTAL SAVING €	209,864	209,864
EPower investment + installation £	70,000€	ROI	4 months

For the full stories and all our successes go to www.eurotherm.com/success



CASE STUDY Energy efficiency with PLM



In today's economy, energy efficiency or, more accurately, the lack of it, is a hotly debated topic. One point that often evades the spotlight is the amount of energy required to actually produce the world's electricity supplies.

Customer Challenge

Our client needed to control power usage across the whole process to comply with strict emissions tolerance legislation to meet efficiency targets for 2020 which detail reduction in greenhouse gasses by 20% and an increase in usable energy efficiency by 20%.

Solution

- Heat treatment installation equipped with EPower
- Using Predictive Load Management to control whole power delivered on installation

Customer Benefits

- Use of PLM means the EPower controller meets industrial demands for energy efficiency and can reduce energy bills by 9%.
- Reduced energy costs by providing more efficient distribution across a variety of loads and conditions.
- Enables customer to stay within emissions tolerance limits – better for the environment
- Accurate record keeping that provides proof of the provider's compliance
- More efficient energy production and distribution for the customer.
- Company executives estimate that the solution will reduce energy costs by improving overall process efficiency by as much as 10%

CASE STUDY Greater energy efficiency using the EPower controller to improve power factor



Our prestigious client had the same problem that most companies have, keeping employees comfortable while they are at work.

Customer Challenge

Our client needed to improve effective climate management in a very large but older office building to ensure a comfortable environment for all employees while avoiding huge energy bills.

Solution

- The Eurotherm solution included EPower three-phase modules, receiving setpoint values via Modbus to a Field Controller, and driving Vulcan Radiator electric baseboard heaters
- Using the Predictive Load Management feature
- Using Zero Cross firing – replacing phase angle SCRs

Customer Benefits

- Improved energy savings
- Reduced previous noise interference
- Power factor improvements
- Created a more comfortable and efficient working environment

Real-world applications

Vacuum furnace in heat treatment

- Heater element control
- Power repartition in heating elements, providing energy saving
- Alarm strategy
- Digital communication allowing supervisory control
- Use Predictive Load Management across multiple furnaces to reduce energy costs

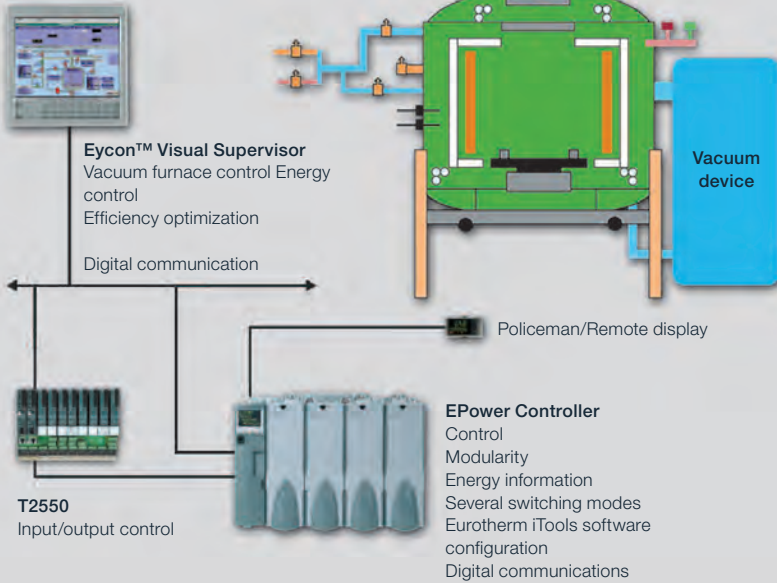

Load tap changer

The load tap changer (LTC) is a method of improving the perceived power factor and harmonic distortion when controlling a load that is required to be driven in phase angle firing mode.

This is achieved by automatically switching a number of taps on the load transformer. This control can be performed on the primary of the transformer where the maximum tap voltage is the limiting factor or the secondary of the transformer where the maximum current is the limiting factor.

The Load Tap Changer requires the External Feedback option.

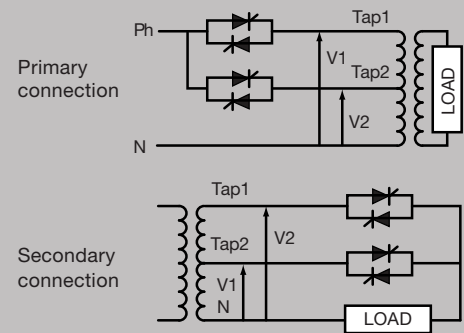

The operating region of control will determine the number of taps required but a maximum of 4 is usually sufficient.

Power Factor Curves for different numbers of taps.

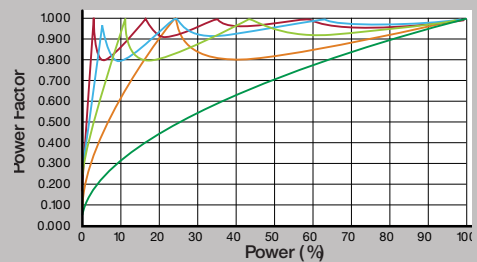

Semiconductor manufacturing

Silicon was discovered in 1823 and is used in the manufacture of today semiconductors.

Semiconductors need a silicon of a very high purity and, therefore, the silicon is transformed by successive stages (crystal growing, epitaxy) that need very slow and accurate heating.

The EPower Controller will provide many solutions to this specific and expensive process:

- Precise and steady control of the heater elements
- Advanced and configurable strategy enables the EPower Controller to adapt to the load state
- Secure your process utilising a comprehensive alarm strategy and by transferring process information to a supervisor



Tin Bath furnace in float manufacturing

Melting is one of the first steps in the 'float' process'. At this stage glass is in liquid state in a molten furnace at around 1550°C. Roof heating is made by silicon carbide heaters. EPower Controller controllers provide all the solutions to the multizone control of this specific heater elements.

- Ageing compensation of the silicon carbide heaters with power control
- Power distribution control in the heater elements providing cost savings: suppression of inrush current for a better energy management and a minimum stress on the power transformers
- Digital communication with standard protocols for an efficient process monitoring
- Use Predictive Load Management across the glass plant to reduce energy costs

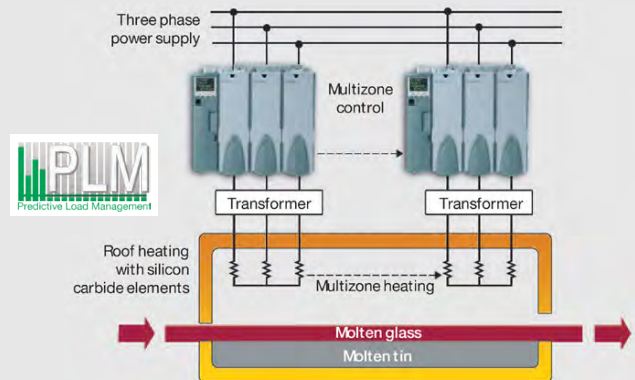

Selection guide and technical specifications

Driver Module			
	Supply Voltage	85 to 264V ac	
	Supply Frequency	7 to 63Hz	
	Power consumption	120W	
	Temperature limits	Operating storage	0 to 50°C max (driver + 4 fans) -25 to 70°C
	Display		4 lines dot LD matrix array
	Communications		Modbus RTU 2 wire EIA485 Modbus TCP/IP 10baseT Ethernet Profibus DPv1 DeviceNet network protocol CC-Link EtherNet/IP ProfiNetIO
	Inputs and Outputs	Standard	2 Analogue inputs 1 Analogue output 2 Digital inputs/outputs 2 Relay SPDT (1= Watchdog)
		Optional modules (max 3)	Per module – 1 Analogue input 1 Analogue output 2 Digital inputs 1 Relay
	Measurement Accuracy		±0.5%
	Remote Panel		Dedicated remote panel port 32h8e panel indicator
	QuickStart		Configurable by order code or on start up via dedicated front panel HMI
	Predictive load management (PLM)		Optional module connecting up to 63 instruments over dedicated communications (CAN based). Configurable PLM (optimises energy usage)
	Software Options		Load Tap Changer (single phase) Energy Counter
	Approvals		CE (EN 60947-4-3), UL 508

Power Modules (Up to 4*)		
	Frequency	47 to 63Hz
	Operating Temperature	Nominally 40°C, Operation 0 to 50°C de-rating applied over 40°C
	Cooling fans/Turbines	≥160A
	Fan/Turbine supply	115V or 230V
	Firing Modes	Phase angle Half Cycle Burst Firing Fixed Modulation Logic
	Load types	Standard Resistive Complex Resistive Inductive loads e.g. Transformer
	Load Configuration	Single phase Ph/Ph or Ph/N Two leg control 3 wire star or delta Three phase control 3 or 4 wire star, 3 or 6 wire delta
	Power module combinations	1, 2, 3 or 4 single phase (1, 2, 3 or 4 modules) 1 or 2 x two leg (2 or 4* modules) 1 x 3 phase (3 modules)
	Feedback Types	Open Loop V2 I2 True Power Vrms Irms
	Compact Power Module	Voltage Ranges
Current ranges in compact version Nominal current range		50A, 100A, 160A, 250A, 400A, 500A, 630A 16 to 630A
Feedback		Internal voltage and current Order option – External voltage and current
Approvals		CE (EN 60947-4-3), UL 508
MC Power Module	Voltage Ranges	100 to 690V ac
	Current ranges in high current version Air Cooled Water Cooled	800A, 1000A, 1300A, 1700A, 2000A 2000A, 3000A, 4000A
	Turbine supply	115V or 230V
	Feedback	External voltage and current
	Approvals	CE (EN 60947-4-3)