

Ceramic Insulated

CHANNEL STRIP HEATERS

**A Reliable Heat Source
with Seamless
Stainless Steel Sheath
For Flat Surface
Mounting Installations,
Used in Hundreds
Of Industrial and Commercial
Heating Applications . . .**

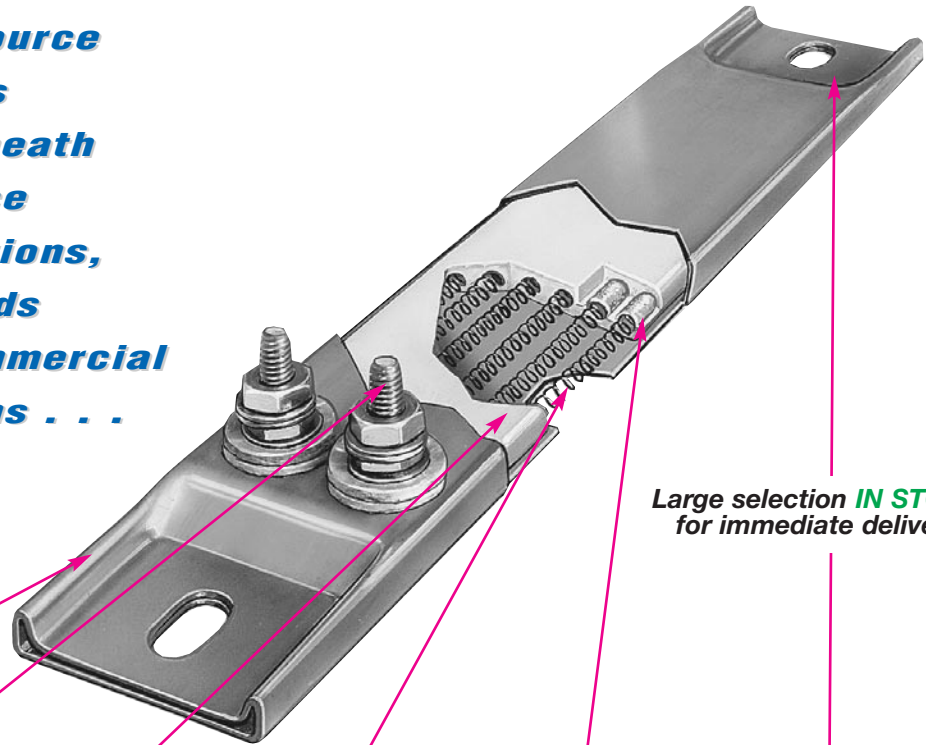

**Large selection IN STOCK
for immediate delivery**

A Type 304
Stainless
Steel

sheath provides the best combination of physical strength and resistance to high temperatures and chemical corrosion. Dependable at sheath temperatures of up to 1200°F (650°C).

B Stainless
Steel
10-32

threaded screws are standard and are securely fastened. Various termination configurations and options are available. See pages 8-4 through 8-7.

C Specially
selected
and de-

signed ceramic insulator houses the resistance wire coil, insulating it from the outer sheath.

D Helically
wound
resistance

wire coil made from nickel-chrome wire is evenly stretched and precisely strung through the ceramic insulator, providing uniform heat. Resistance wire is then mechanically connected to screw terminals or lead wires for a strong positive joint.

E A custom
mixture
of several

high purity magnesium oxide grain sizes, chosen to increase thermal conductivity and dielectric strength, are used to fill all remaining space inside and around the ceramic insulator. Voids are densely packed.

F Channel
strip
heaters

are available with or without mounting tabs. If without, the ends are silver soldered shut to prevent moisture and contaminants from entering the heater.

Typical Applications

- ➔ Ovens
- ➔ Hot Plates
- ➔ Dies
- ➔ Molds
- ➔ Drying
- ➔ Melting
- ➔ Baking
- ➔ Incubators
- ➔ Platens
- ➔ Food Warmers
- ➔ Welding Preheating
- ➔ Air Heating
- ➔ Sealing Bars
- ➔ Thermoforming
- ➔ Tank Heating



Note: Channel Strip Heaters are available with fins for air heating applications. See pages 8-12 through 8-15.

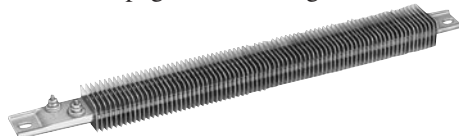

Agency Approvals



Channel Strip Heaters have been certified as Recognized Components by Underwriters Laboratories (File Number E65652) under CCN KSOT2/8 to meet UL standard 499 and Canadian Standard C22.2, No 72.

This file specifies the end use limitations and conditions of acceptability for the use of this type of heater. For additional information consult Tempco.

If you require UL, CSA, or other NRTL Agency Approvals, please specify when ordering.

Ceramic Insulated Channel Strip Heaters

Channel Strip Heaters have proven to be extremely efficient and dependable as a heat source for surface heating in hundreds of industrial and commercial applications.

For surface mounting installations, Channel Strip heaters must be securely clamped along their entire length to a smooth metal surface. When supported by mounting tabs, the terminal end should be secured firmly. Opposite end should be loose to allow for thermal expansion.

TEMPCO offers Channel Strip Heaters in three rectangular sizes

1" WIDE BY 5/16" THICK

Available with or without mounting tabs. When supplied with Type L lead wire termination, mounting tabs are not available.

1-1/2" WIDE BY 5/16" THICK

Available with or without mounting tabs. When supplied with Type L lead wire termination, mounting tabs are not available.

1-1/2" WIDE BY 3/8" THICK

Available with or without mounting tabs. When supplied with Type L lead wire termination, mounting tabs are not available.
(3/8" thick heaters have radius corners)



Standard Specifications and Tolerances of Channel Strip Heaters
If tighter tolerances are required, consult Tempco.

PERFORMANCE RATINGS

Maximum Sheath Temperature: 1200°F (650°C)
Nominal Watt Density: 20 W/in² (3.1 W/cm²)
Maximum Watt Density: 45 W/in² (dependent on design parameters)

ELECTRICAL SPECIFICATIONS

Maximum Voltage: 480VAC (dependent on design parameters)
Maximum Recommended Voltage with Leads: 480V
Maximum Amperage: Lead Wire Termination: 10 amp
 Screw Terminations: 10-32UNF—25 amp
Resistance Tolerance: +10%, -5%
Wattage Tolerance: +5%, -10%

PHYSICAL SIZE CONSTRUCTION LIMITATIONS

Width
 1" and 1-1/2" wide heaters +.000, -.010"

Length
 Up to 24" ±1/16"
 Over 24" ±1/8"

Mounting Slot Size
 Standard 5/16" × 1/2"
 Special Bushings 1/2" × 5/8"

Terminations

Screw Terminal Terminations

Type T1

- 10-32 Screw Terminals at each end
- Available on 1" and 1-1/2" wide heaters



No Mounting Tabs

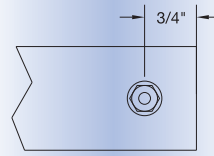

With Mounting Tabs

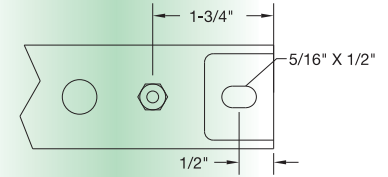

Type T2

- 10-32 Screw Terminals (Tandem) at one end
- Available on 1" and 1-1/2" wide heaters

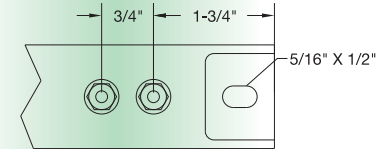
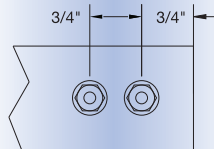
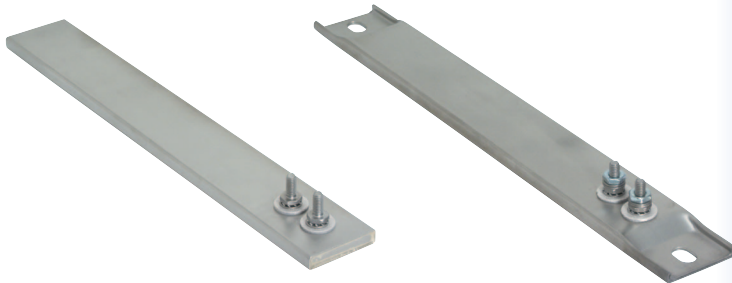

Type T3

- 10-32 Screw Terminals (Parallel) at one end
- Available on 1-1/2" wide heaters only

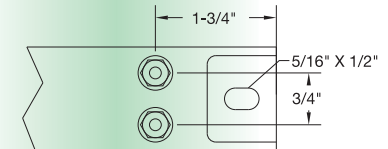
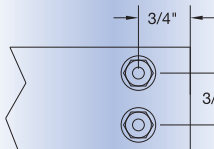
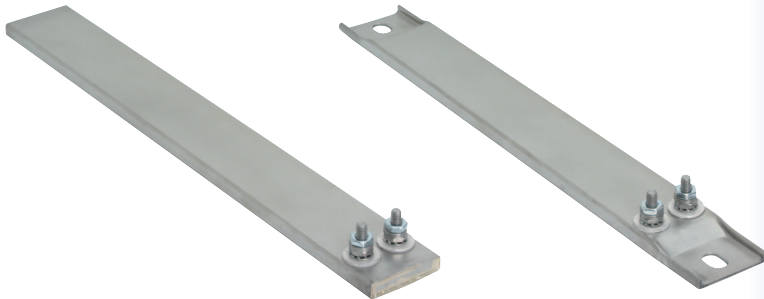

Type T4

- 10-32 Screw Terminals offset at one end
- Available on 1-1/2" wide heaters only

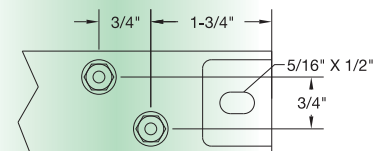
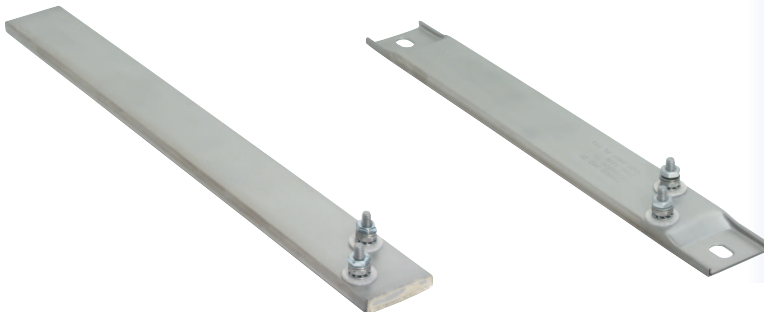

10-32 Screw Terminal Height

31/32"

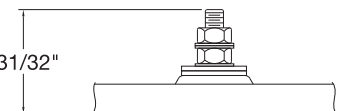

Lead Wire Terminations

Type L Flexible lead wires exit from end of heater. 10" long leads standard; if longer leads are required, specify. Recommended only for tight quarters or where flexibility of the lead wire is required. Not available on heaters with tabs.

Maximum Amps: 10 at 240VAC **Maximum Volts:** 480



Type L1 Flexible lead wires exit from top of heater. 10" long leads standard; if longer leads are required, specify.

Maximum Amps: 10 at 240VAC **Maximum Volts:** 480

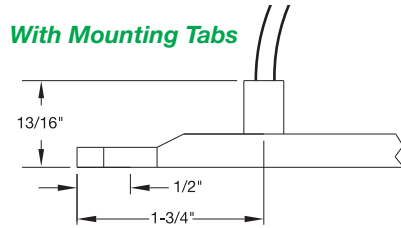
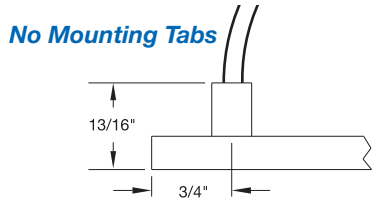
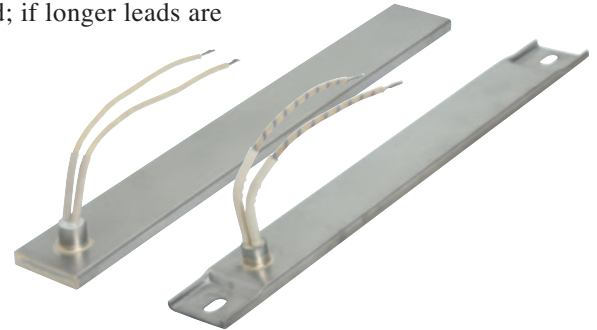

Type W1 Wire braid provides strength and protection to the lead wire insulation, offering sharp bending not possible with armor cable. 10" of wire braid over 12" long leads is standard; if longer leads or braid are required, specify.

Maximum Amps: 10 at 240VAC **Maximum Volts:** 480

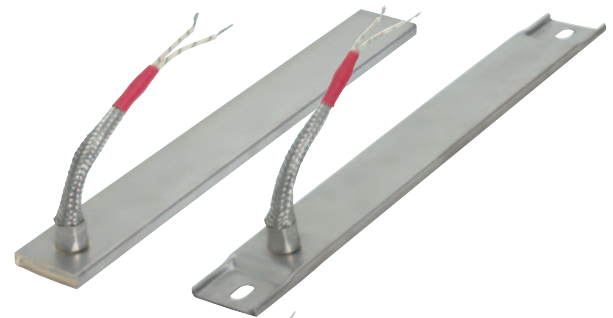
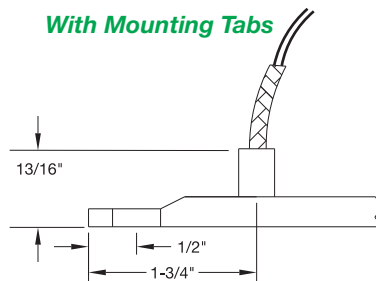
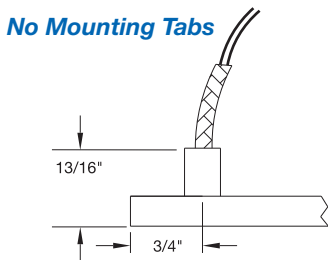

Type W2 Stainless steel braid over each lead wire offers sharp bending not possible with armor cable, as well as abrasion protection. 10" long leads standard; if longer leads are required, specify. Not available on heaters with tabs.

Maximum Amps: 10 at 240VAC **Maximum Volts:** 480



Type R1 Armor cable provides strength and prevents contamination from getting into the heater. 10" of armor over 12" long leads are standard; if longer leads or armor are required, please specify.

Maximum Amps: 10 at 240VAC **Maximum Volts:** 480

Type R1A: Galvanized cable **Type R1B:** Stainless steel cable

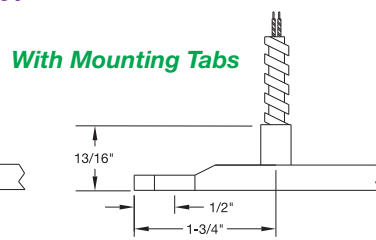
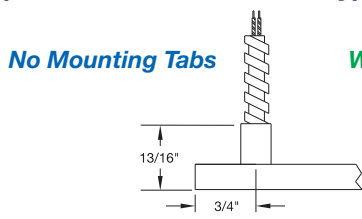

CONTINUED →

Terminations

Continued from previous page...

Type R2 Right-angle armor cable prevents contamination from getting into the heater. 10" of armor over 12" long leads is standard; if longer leads or armor are required, please specify.

Maximum Amps: 10 at 240VAC **Maximum Volts:** 480

Type R2A Galvanized cable

Type R2B Stainless steel cable

Type R2C Elbow and leads only (no cable)

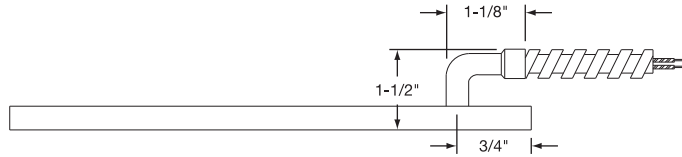

No Mounting Tabs

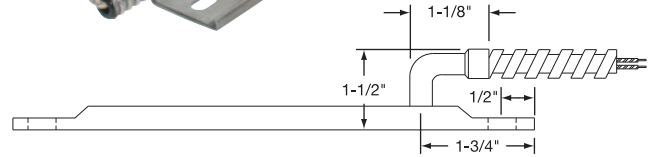
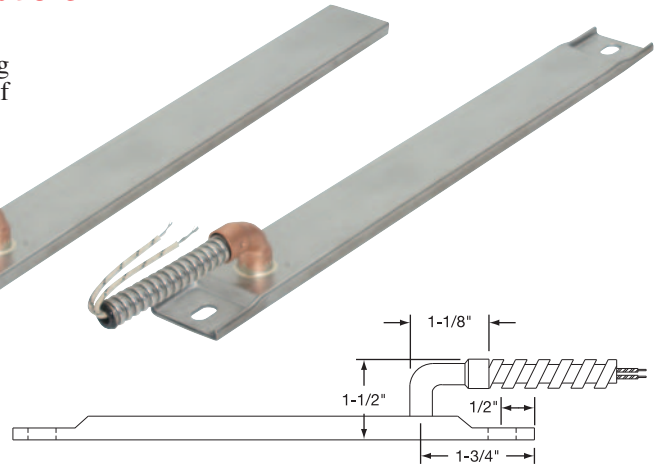

With Mounting Tabs

Terminal Protection

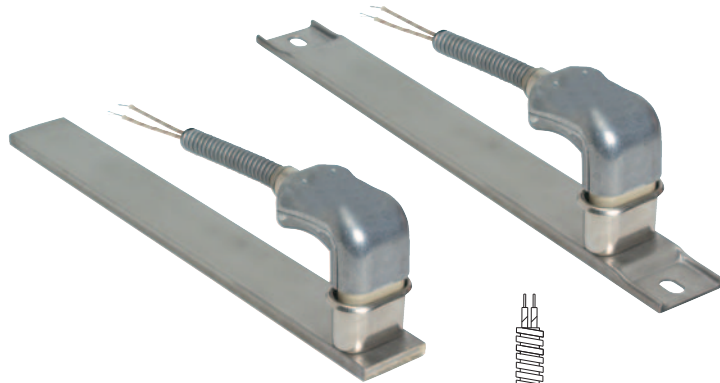

Type P High-Temperature Quick Disconnect Plug. If armor protected lead wires are required, specify armor and lead length. Available on 1-1/2" wide heaters only.

Maximum Amps: 10 at 240VAC **Maximum Volts:** 250

Type P1A Cup only (UT900)

Type P1B Cup and straight plug (H900)

Type P1C Cup and 90° plug (HW900)

Type P1D Cup, straight plug and galvanized cable

Type P1G Cup, 90° plug and galvanized cable

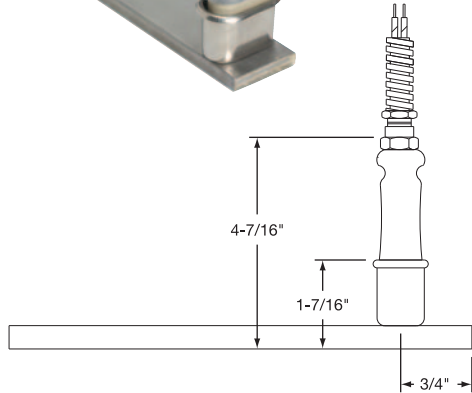

No Mounting Tabs (Type P1D Shown)

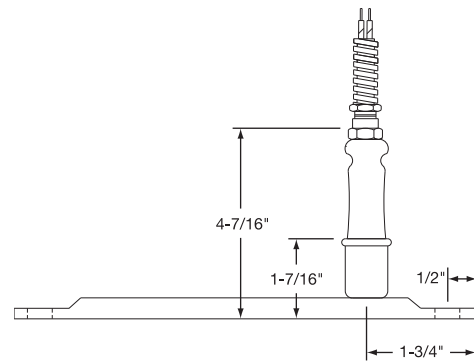

With Mounting Tabs (Type P1D Shown)

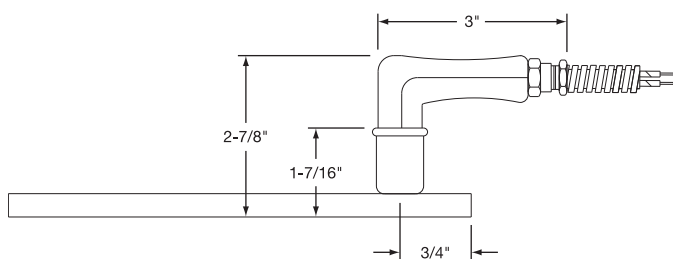

No Mounting Tabs (Type P1G Shown)

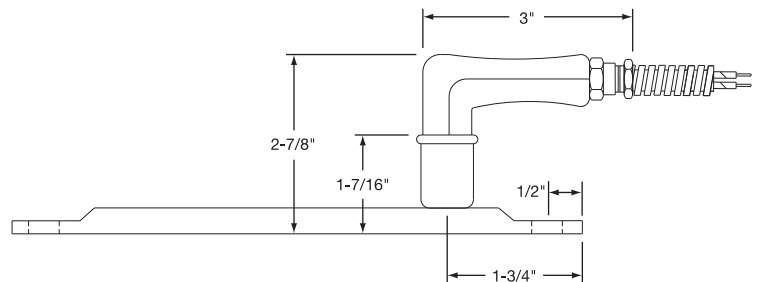

With Mounting Tabs (Type P1G Shown)

Exposed electrical wiring on Strip Heaters is a violation of electrical safety codes, including O.S.H.A.

Terminal Protection

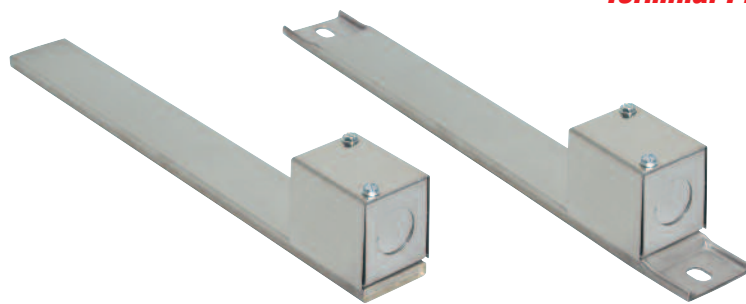

Type C Terminal box has a 1/2" trade size knockout (actual diameter 7/8"). Box provides excellent protection to exposed terminals. If armor-protected lead wires are required, specify armor and lead length. Available on 1" and 1-1/2" wide heaters.

- Type CA** No cable or braid
- Type CB** Galvanized cable
- Type CC** Stainless steel cable
- Type CD** Wire braid

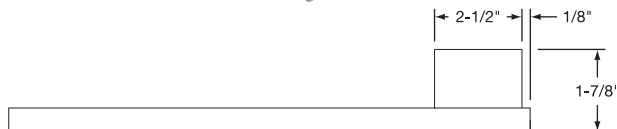

No Mounting Tabs

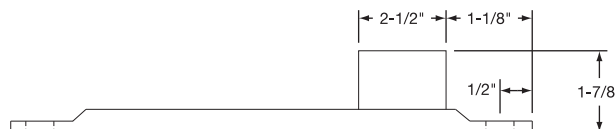

With Mounting Tabs

Type MP Specially designed box is welded to the Channel Strip Heater and potted with epoxy. The ends of the heater are also welded. Leads exit through a 1/2" NPT nut that can be located at the top or in the front of the box. Armor cable can be supplied with the male fitting, providing a completely sealed Channel Strip. Available on 1 1/2" wide heaters only.

10" long leads standard; if longer leads are required, specify.

Maximum Amps: 25 **Maximum Volts:** 480

- Type MPA** Box only
- Type MPB** Box with prewired galvanized cable
- Type MPC** Box with prewired stainless steel cable
- Type MPD** Box with prewired wire braid

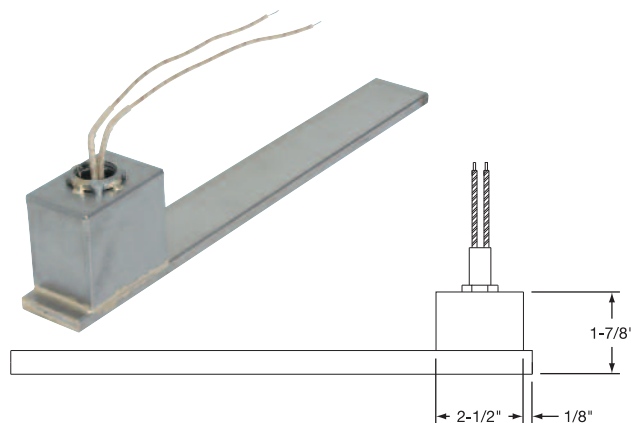

Ceramic Covers for Insulating Screw Terminals

Igloo™ Igloo Ceramic terminal covers consist of two individual ceramic parts. With a tight-fitting cap and a solid base, an Igloo cover will fully insulate any standard 10-32 terminal lug used for electrical wiring hookups. Igloo covers can be assembled on all Channel Strip heaters with Type T1 and Type T4 screw terminals.



Type C6

Double Port In-Line

Part Number: CER-101-104



Type C7

Double Port 90°

Part Number: CER-101-106



Type C8

Single Port

Part Number: CER-101-107

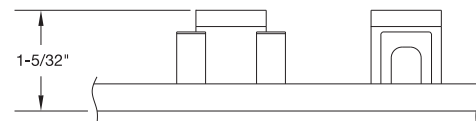

Ceramic Cap

Thread 10-32 **Part Number** CER-102-101

Three different types of Igloo bases are available for your wiring convenience. Double Port In-Line, Double Port 90° and Single Port. When ordering, specify the type of Igloo.

Strip Heaters



Standard Sizes and Ratings

Standard (Non-Stock) Sizes and Ratings

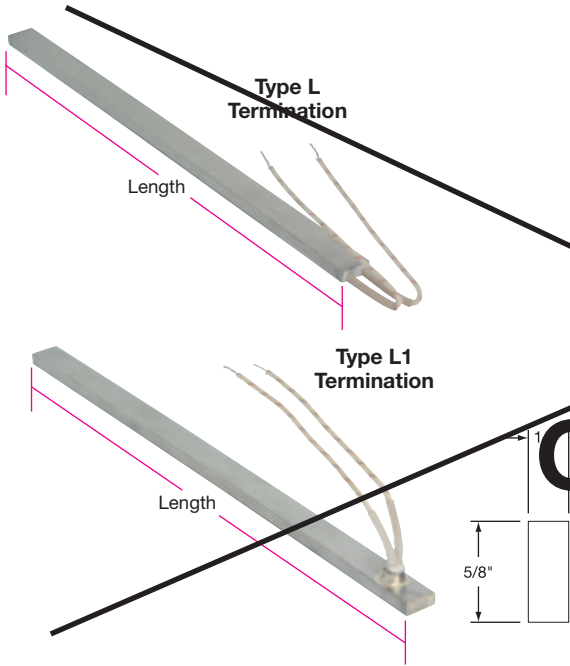

5/8" x 1/4" (15.88 x 6.35 mm) Channel Strip Heaters

Part numbers shown are for heaters with Type L Termination with 10" plain leads or Type L1 Termination with 10" plain leads.

- Additional available terminations: Type R2 and Type W1
- Mounting tabs are not available on this size.

Length in mm	Wattage	Watt Density		Type	Part Number	
		W/in ²	W/cm ²		120V	240V
1½ 38.1	50	29	4	L	CSH00001	—
2 50.8	50	19	3	L	CSH00002	—
3 76.2	150	34	5	L	—	CSH00003
3 76.2	150	34	5	L1	—	CSH00004
4 101.6	200	33	5	L	CSH00005	—
5 127.0	240	30	5	L	CSH00006	—
5 127.0	240	30	5	L1	CSH00007	CSH00008
6 152.4	240	22	3	L1	CSH00009	—
8 203.2	350	24	4	L	CSH00010	CSH00011
9 228.6	350	24	4	L1	CSH00012	—
12 304.8	500	25	4	L	—	CSH00013
13 330.2	500	23	4	L	CSH00014	—
14 355.6	550	23	4	L1	—	CSH00015
18 457.2	900	29	5	L	CSH00016	—
18 457.2	900	29	5	L1	CSH00017	CSH00018
20 508.0	1000	29	5	L1	CSH00019	CSH00020

Obsolete

1" x 5/16" (25.4 x 7.94 mm) Channel Strip Heaters Channel Strip Heaters with T2 Terminals and Mounting Tabs

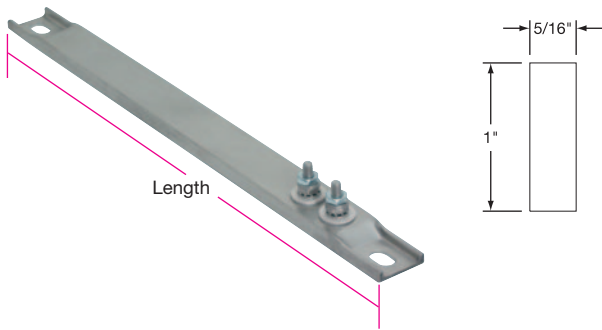

Length in mm	Wattage	Watt Density		Part Number	
		W/in ²	W/cm ²	120V	240V
8 203.2	250	13	2	CSH00021	—
9½ 241.3	300	13	2	CSH00022	—
11 279.4	350	13	2	CSH00023	—
12 304.8	400	13	2	CSH00024	CSH00025
14 355.6	450	13	2	CSH00026	CSH00027
15¼ 387.4	500	13	2	CSH00028	CSH00029
17¼ 454.0	600	13	2	CSH00030	CSH00031
19½ 495.3	600	12	2	CSH00032	CSH00033
21 533.4	750	14	2	CSH00034	CSH00035
22½ 571.5	750	13	2	CSH00036	CSH00037
23¾ 603.3	800	13	2	CSH00038	CSH00039
25½ 647.7	900	14	2	CSH00040	CSH00041
27½ 698.5	900	13	2	CSH00042	CSH00043
28¾ 730.3	1000	13	2	CSH00044	CSH00045
30½ 774.7	1000	13	2	CSH00046	CSH00047
33½ 850.9	1000	12	2	CSH00048	CSH00049
35¾ 911.2	1000	11	2	CSH00050	CSH00051
38½ 977.9	1250	13	2	CSH00052	CSH00053

Ordering Information

Catalog Heaters

Select a Channel Strip Heater from the Standard Sizes and Ratings lists on pages 8-8 through 8-11.

Channel Strip Heaters whose Part Numbers are in **RED** are available from Stock for immediate delivery.

Standard Non-Stock Part Numbers have a 3-week lead time.

Custom Engineered/Manufactured Heaters

An electric heater can be very application specific; for sizes and ratings not listed, **TEMPCO** will design and manufacture a Channel Strip Heater to meet your requirements. **Standard lead time is 3 weeks.**

Please Specify the following:

- Width & Thickness
- Length
- Wattage
- Voltage
- Termination (see pages 8-4 through 8-7)
- Lead Cable/Braid Length
- Special Features
- Quantity

⚠ WARNING: Cancer and Reproductive Harm - www.P65Warnings.ca.gov.

Standard (Non-Stock) and Stock Sizes and Ratings

1-1/2" x 5/16" (38.1 x 7.94 mm)

Channel Strip Heaters with T1 Terminals and Mounting Tabs

Stock Items Are Shown In **RED**

Length in mm	Wattage	Watt Density		Part Number		
		W/in ²	W/cm ²	120V	240V	
6	152.4	150	21	3	CSH00316	CSH00583
8	203.2	150	14	2	CSH00218	CSH00219
8	203.2	250	23	4	CSH00220	CSH00221
9½	241.3	200	12	2	CSH00222	CSH00223
9½	241.3	300	18	3	CSH00224	CSH00225
10½	266.7	250	13	2	CSH00226	CSH00227
12	304.8	250	10	2	CSH00228	CSH00229
12	304.8	500	20	3	CSH00230	CSH00231
12	304.8	350	12	2	CSH00345	CSH00528
14	355.6	300	9	1	CSH00232	CSH00233
14	355.6	500	15	2	CSH00234	CSH00235
15¼	387.4	325	9	1	CSH00236	CSH00237
15¼	387.4	500	13	2	CSH00238	CSH00239
17⅞	454.2	375	8	1	CSH00240	CSH00241
17⅞	454.2	500	11	2	CSH00242	CSH00243
17⅞	454.2	750	16	2	CSH00244	CSH00245
17⅞	454.2	1000	21	3	CSH00246	CSH00247
19½	495.3	500	10	1	CSH00248	CSH00249
19½	495.3	750	14	2	CSH00250	CSH00251
19½	495.3	1000	19	3	CSH00252	CSH00253
19½	495.3	1200	23	4	CSH00326	CSH00330
21	533.4	500	9	1	CSH00254	CSH00255
23¾	603.3	250	4	1	CSH00256	CSH00257
23¾	603.3	500	7	1	CSH00258	CSH00259
23¾	603.3	750	11	2	CSH00260	CSH00261
23¾	603.3	1000	15	2	CSH00262	CSH00263
23¾	603.3	1500	22	3	CSH00264	CSH00265
25½	647.7	750	10	2	CSH00266	CSH00267

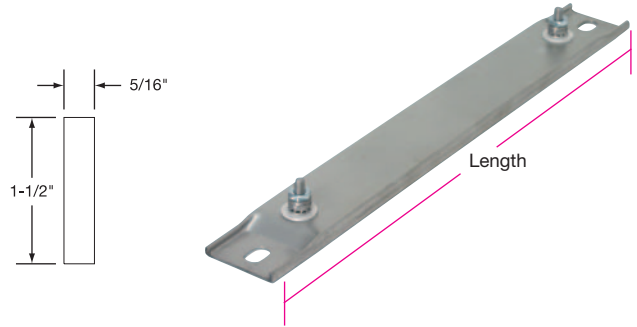

Stock Items Are Shown In **RED**

Length in mm	Wattage	Watt Density		Part Number		
		W/in ²	W/cm ²	120V	240V	
25½	647.7	1000	13	2	CSH00268	CSH00269
26¾	679.5	700	9	1	CSH00270	CSH00271
26¾	679.5	750	10	1	CSH00272	CSH00273
29¼	742.0	750	8	1	CSH00347	CSH00348
29⅞	758.8	750	8	1	CSH00274	CSH00275
30½	774.7	750	8	1	CSH00276	CSH00277
33½	850.9	750	7	1	CSH00278	CSH00279
33½	850.9	1000	10	2	CSH00280	CSH00281
34⅞	879.5	1000	9	1	CSH00282	CSH00283
35⅞	911.4	1000	9	1	CSH00284	CSH00285
37¼	946.2	1500	13	2	CSH00286	CSH00287
38½	977.9	1000	8	1	CSH00288	CSH00289
42½	1079.5	1250	9	1	CSH00290	CSH00291
42½	1079.5	1500	11	2	CSH00292	CSH00293

1-1/2" x 5/16" (38.1 x 7.94 mm)

Channel Strip Heaters with T2 Terminals and Mounting Tabs

Stock Items Are Shown In **RED**

Length in mm	Wattage	Watt Density		Part Number		
		W/in ²	W/cm ²	120V	240V	
6	152.4	150	21	3	CSH00317	CSH00320
8	203.2	150	13	2	CSH00189	CSH00190
8	203.2	250	21	3	CSH00342	CSH00343
8	203.2	500	42	7	CSH00322	CSH00325
10½	266.7	250	12	2	CSH00191	CSH00192
12	304.8	350	13	2	CSH00193	CSH00194
14	355.6	500	15	2	CSH00195	CSH00196
17⅞	454.2	750	16	2	CSH00197	CSH00198
19½	495.3	1200	23	4	CSH00327	CSH00331
23¾	603.3	750	11	2	CSH00199	CSH00200
25½	647.7	500	7	1	—	CSH00201
29¼	743.0	750	8	1	CSH00202	CSH00203
33½	850.9	750	7	1	CSH00204	—
34⅞	879.5	1000	9	1	CSH00205	CSH00206
35⅞	911.2	1000	9	1	CSH00207	CSH00208
37¼	946.2	1500	13	2	CSH00209	CSH00210

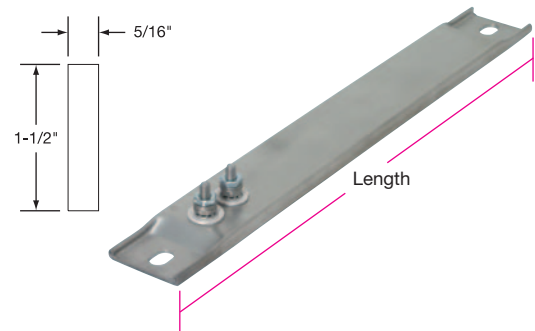

Length in mm	Wattage	Watt Density		Part Number		
		W/in ²	W/cm ²	120V	240V	
38½	977.9	800	7	1	CSH00211	—
53⅞	1368.6	1500	8	1	—	CSH00212
53⅞	1368.6	2500	14	2	—	CSH00213
63⅞	1622.6	1800	8	1	—	CSH00214
63⅞	1622.6	3000	14	2	—	CSH00215
71⅞	1825.8	2000	8	1	—	CSH00216
71⅞	1825.8	3000	12	2	—	CSH00217

Strip Heaters



Standard Sizes and Ratings

Standard (Non-Stock) and Stock Sizes and Ratings

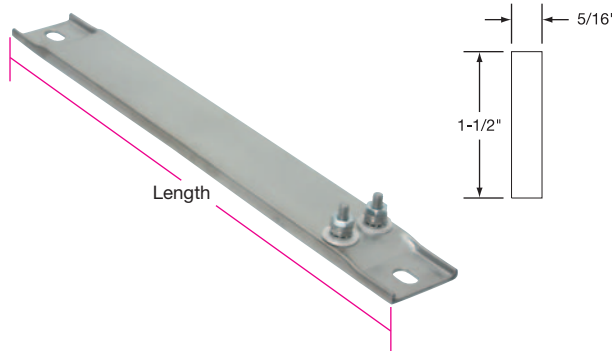

1-1/2" x 5/16" (38.1 x 7.94 mm)
Channel Strip Heaters with T3 Terminals
and Mounting Tabs

Stock Items Are Shown In **RED**

Stock Items Are Shown In **RED**

Length in mm	Wattage	Watt Density		Part Number	
		W/in ²	W/cm ²	120V	240V
5¼ 133.4	125	20	3	CSH00336	CSH00337
5½ 139.7	125	23	4	CSH00159	CSH00160
5½ 139.7	250	34	5	CSH00161	CSH00162
5¾ 146.1	300	47	7	CSH00163	CSH00164
6 152.4	150	17	3	CSH00165	CSH00166
6 152.4	300	41	6	CSH00167	CSH00168
8 203.2	150	10	2	CSH00169	CSH00170
8 203.2	250	17	3	CSH00344	CSH00171
8 203.2	500	34	5	CSH00323	CSH00324
10½ 266.7	250	11	2	CSH00172	CSH00173
10½ 266.7	400	17	3	CSH01618	CSH01433
12 304.8	250	9	1	CSH01600	CSH01601
12 304.8	350	12	2	CSH00346	CSH00174
14 355.6	300	8	1	CSH01602	CSH01603
14 355.6	500	14	2	CSH00175	CSH00176
15¼ 387.4	325	8	1	CSH01604	CSH01605
17⅞ 454.2	500	11	2	CSH01606	CSH01607
17⅞ 454.2	750	15	2	CSH00177	CSH00178
17⅞ 454.2	1000	21	3	—	CSH01257
19½ 495.3	350	7	1	CSH01608	CSH01609

Length in mm	Wattage	Watt Density		Part Number	
		W/in ²	W/cm ²	120V	240V
19½ 495.3	1200	21	3	CSH00328	CSH00332
21 533.4	500	8	1	CSH01610	CSH01611
21 533.4	750	13	2	CSH01620	CSH01621
23¾ 603.3	750	10	2	CSH00179	CSH00180
23¾ 603.3	1000	15	2	CSH01624	CSH01625
25½ 647.7	500	7	1	CSH01613	CSH01614
26¾ 679.5	700	9	1	CSH01615	CSH01616
26¾ 679.5	1000	13	2	CSH01655	CSH01626
29¼ 743.0	750	8	1	CSH00181	CSH00182
30½ 774.7	750	8	1	CSH01627	CSH01628
30½ 774.7	1250	13	2	—	CSH01629
33½ 850.9	950	9	1	CSH01630	CSH01631
34⅞ 879.5	1000	9	1	CSH00183	CSH00184
35⅞ 911.4	1000	9	1	CSH00185	CSH00186
35⅞ 911.4	1500	13	2	—	CSH00462
37¼ 946.2	1500	12	2	CSH00187	CSH00188
42½ 1079.5	1500	11	2	—	CSH01632
45½ 1155.7	1250	8	1	—	CSH01617
47⅞ 1216.0	2250	14	2	—	CSH01230

Ordering Information

See page 8-8

Type ARC Channel Strip Radiant Heater Arrays



Tempco can design and manufacture a custom channel strip heater array for applications requiring infrared heat. Call for details.

Other type of infrared heaters can be found in [Section 7](#).



Standard (Non-Stock) Sizes and Ratings

1-1/2" x 5/16" (38.1 x 7.94 mm) Channel Strip Heaters with T4 Terminals and Mounting Tabs

Stock Items Are Shown In RED

Length in mm	Wattage	Watt Density		Part Number		
		W/in ²	W/cm ²	120V	240V	
5¼	133.4	125	34	5	CSH00338	CSH00339
5¾	146.1	300	55	8	CSH01596	CSH01595
6	152.4	150	24	4	CSH00318	CSH00321
7½	190.5	150	15	2	CSH00054	CSH00055
7½	190.5	200	20	3	CSH00056	CSH00057
8	203.2	150	13	2	CSH00058	CSH00059
8	203.2	175	15	2	CSH00060	CSH00061
8	203.2	250	21	3	CSH00062	CSH00063
8	203.2	400	31	5	CSH00064	CSH00065
8	203.2	500	42	7	CSH00066	CSH00067
10½	266.7	250	12	2	CSH00068	CSH00069
10½	266.7	350	17	3	CSH00070	CSH00071
10½	266.7	400	19	3	CSH00072	CSH00073
12	304.8	250	10	1	CSH00074	CSH00075
12	304.8	350	13	2	CSH00076	CSH00077
12	304.8	500	19	3	CSH00078	CSH00079
14	355.6	300	9	1	CSH00080	CSH00081
14	355.6	500	15	2	CSH00082	CSH00083
15¼	387.4	325	9	1	CSH00084	CSH00085
15¼	387.4	500	13	2	CSH00086	CSH00087
17⅞	454.2	350	7	1	CSH00088	CSH00089
17⅞	454.2	375	8	1	CSH00090	CSH00091
17⅞	454.2	500	11	2	CSH00092	CSH00093
17⅞	454.2	750	16	2	CSH00094	CSH00095
17⅞	454.2	1000	23	3	CSH00096	CSH00097
19½	495.3	350	7	1	CSH00098	CSH00099
19½	495.3	500	9	1	CSH00100	CSH00101
19½	495.3	750	14	2	CSH00102	CSH00103
19½	495.3	1000	19	3	CSH00104	CSH00105
19½	495.3	1200	23	4	CSH00329	CSH00333
21	533.4	500	8	1	CSH00106	CSH00107
21	533.4	750	13	2	CSH00108	CSH00109
23¾	603.3	500	7	1	CSH00110	CSH00111
23¾	603.3	750	11	2	CSH00112	CSH00113

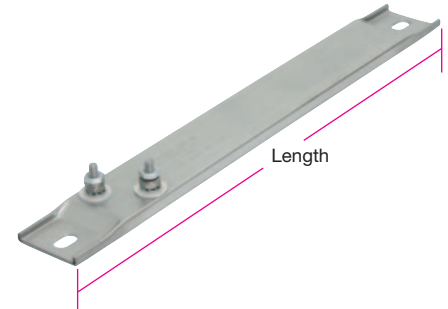
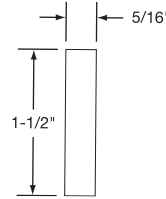

Stock Items Are Shown In RED

Length in mm	Wattage	Watt Density		Part Number		
		W/in ²	W/cm ²	120V	240V	
23¾	603.3	1000	15	2	CSH00114	CSH00115
23¾	603.3	1500	22	3	CSH00116	CSH00117
25½	647.7	500	7	1	CSH00118	CSH00119
25½	647.7	750	10	2	CSH00120	CSH00121
25½	647.7	1000	13	2	CSH00122	CSH00123
26¼	679.5	700	9	1	CSH00124	CSH00125
26¼	679.5	750	9	1	CSH00126	CSH00127
26¼	679.5	1000	13	2	CSH00128	CSH00129
29¼	743.0	750	8	1	CSH00130	CSH00131
30½	774.7	750	8	1	CSH00132	CSH00133
30½	774.7	1000	11	2	CSH00134	CSH00135
30½	774.7	1250	13	2	—	CSH00136
33½	850.9	750	7	1	CSH00137	CSH00138
34%	879.5	1000	9	1	CSH00139	CSH00140
35%	911.4	1000	9	1	CSH00141	CSH00142
35%	911.4	1500	13	2	CSH00143	CSH00144
37¼	946.2	1500	13	2	CSH00145	CSH00146
38½	977.9	800	7	1	CSH00147	CSH00148
38½	977.9	1000	8	1	CSH00149	CSH00150
38½	977.9	1500	12	2	CSH00151	CSH00152
42½	1079.5	1250	9	1	CSH00153	CSH00154
42½	1079.5	1500	11	2	CSH00155	CSH00156
47%	1216.2	1350	9	1	—	CSH00157
47%	1216.2	2250	14	2	—	CSH00158

1-1/2" x 3/8" (38.1 x 9.53 mm) Channel Strip Heaters with T4 Terminals and Mounting Tabs

Length in mm	Wattage	Watt Density		Part Number		
		W/in ²	W/cm ²	120V	240V	
7½	190.5	200	19	3	—	CSH00294
9	228.6	500	31	5	—	CSH00295
10½	266.7	250	12	2	CSH00296	—
10½	266.7	400	19	3	CSH00297	—
12	304.8	500	18	3	—	CSH00298
15¼	387.4	500	13	2	—	CSH00299
17	431.8	1000	22	3	—	CSH00300
17⅞	454.0	350	7	1	—	CSH00301
17⅞	454.0	500	10	2	—	CSH00302
18	457.2	1000	20	3	—	CSH00303
18½	469.9	500	10	2	—	CSH00304
22½	571.5	1000	15	2	—	CSH00305
24	609.6	1000	14	2	—	CSH00306
25½	647.7	1000	13	2	—	CSH00307
26	660.4	1600	20	3	—	CSH00308
26½	673.1	1500	18	3	—	CSH00309

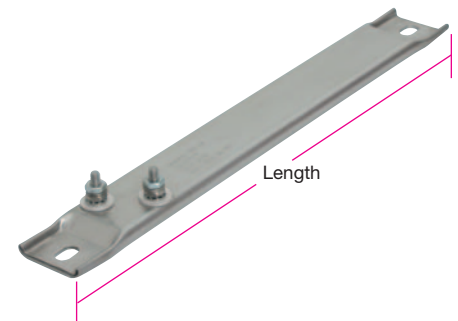
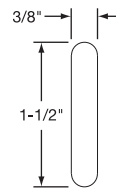

Length in mm	Wattage	Watt Density		Part Number		
		W/in ²	W/cm ²	120V	240V	
30½	774.7	750	8	1	—	CSH00310
31½	800.1	800	8	1	—	CSH00311
35%	911.2	1000	9	1	—	CSH00312
36	914.4	1000	9	1	—	CSH00313
50	1270.0	1000	6	1	—	CSH00314
62	1574.8	1500	7	1	—	CSH00315