



PHASETRONICS™

SCR Power Control Specialists

EZ2 *Series*

**10 to 1000 Amp Models
SCR Power Controller**

OPERATION AND SERVICE MANUAL

Table of Contents

Chapter 1 - Introduction	3
1.1 Description	3
1.2 Receiving and Unpacking	3
Chapter 2 - Specifications	4
2.1 Specification	4
Chapter 3 - Connections	5
3.1 Control Diagrams	5
3.2 Manual Control	7
3.3 Automatic Control	7
3.4 Power Connections	8
3.5 Other Connections	12
Chapter 4 – Start-up Procedure	12
4.1 Manual Control	12
4.2 Automatic Control	12
Chapter 5 - Dimensions	13
5.1 Unit Dimensions	13
Appendix	16
A1 EZCL and ZCL Board Connectors, Jumpers and Test Points	16
A2 Replacement Parts	18
A3 EZ2 Model Selection Guide	19
WARRANTY INFORMATION	19

Chapter 1 - Introduction

1.1 Description

TRUE ZERO VOLTAGE SWITCHING Phasetronics' new EZ SERIES zero voltage switching controllers are designed to fire at the absolute minimum voltage differential across the SCR with a gate pulse applied prior to the zero crossing point. These controllers are virtually RFI free.

VARIABLE TIME PROPORTIONING EZ SERIES zero fired (Variable time base) SCR Power Controllers combine low cost with microprocessor technology. The EZ SERIES features a rapid-cycle control technique that provides resolution that potentially extends the life of industrial resistance heaters.

This variable time base control technique minimizes off time and is characterized by rapid on/off cycling with on-to-on cycle time ranging from 1 to 3 cycles for power ranges of 25% to 100%. Thermal cycling of the heater elements is reduced to a minimum for all power levels to improve element life. Control of the on-to-on cycle times provides the resolution required to maintain a smooth, even output from resistance heaters. The number of on cycles within a burst and the off time between bursts is continually monitored and updated by the microprocessor. A constant heater output is ensured since the units output will continuously change to satisfy load requirements. For example, the maximum off period from 50% power to 100% power is one cycle.

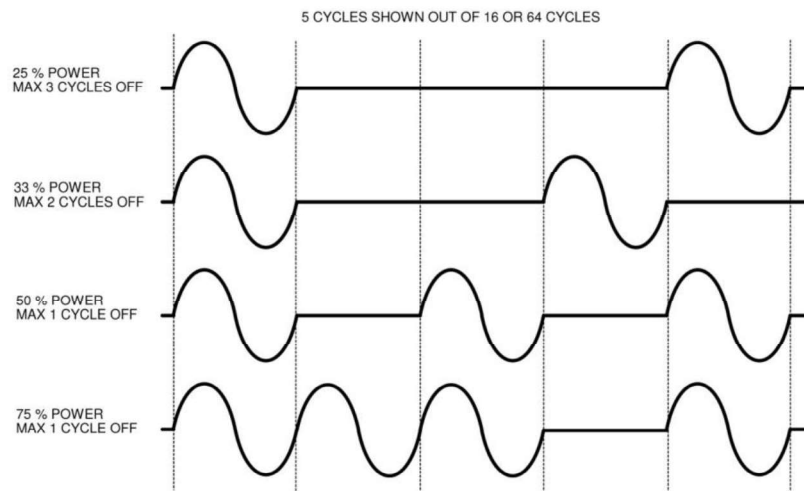

Figure 1

1.2 – Receiving and Unpacking

UNPACKING Carefully unpack the SCR Power Controller from the shipping carton and inspect it for shipping damage. Immediately report any damages to the carrier.

MOUNTING Select mounting location and make sure ambient temperature does not exceed operating range limits given in specifications. Mount units vertically so that heatsink fins are parallel to vertical mounting surface. Make sure that clearance on top and bottom of unit is at least six (6) inches.

WIRING Connection Diagrams Illustrate typical wiring connections for given controller models.

Note: All wiring must comply with local and national electrical codes and should only be done by qualified, certified electricians.

Warning

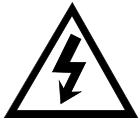

DO NOT SERVICE EQUIPMENT WITH VOLTAGE APPLIED! Unit can be a source of fatal electrical shocks! To avoid shock hazard, disconnect all power sources before working on unit.

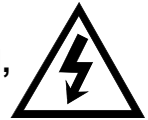

Chapter 2 - Specifications

2.1 - Specifications

External Inputs	Automatic Signal Input	4-20 mA Input Impedance - 500 ohm. 0-5 mA Input Impedance – 2K ohm. 10-50 mA Input Impedance - 200 ohm. 0-10V Input Impedance – 34K ohm.
	Manual Control	10K ohm, linear taper (customer provided). NOTE: If no external auto/manual switch is used, then whichever of the two input signals (Manual Potentiometer or Automatic Signal) is greater, will control the unit.
Output Voltage		0 to 100%
Output Stage		Back to Back SCR configuration
AC Supply Voltage		120/208/240/380/415/480/575 Vac (+10% to -15%, 50/60 Hz) See appendix A3 – EZ2-Model Selection Guide
Type of Loads		Resistive Only.
LED Readouts		PC board mounted LED's Indicate on and output. A plug connection offers the ability to move these readouts to a remote location.
Output Time Base		Selectable: 16 steps or 64 steps.
Protective Networks	Transient Voltage Suppressor	Integral MOV (Metal Oxide Varistor) protects against high potential transient voltage.
	SCR Peak Inverse Voltage (PIV Rating)	Units up to 100A: 1600V Units 150A to 1000A: 1800V
Cooling		Convection cooling through 150A. Fan cooled at 225A and above.
Ambient Temperature		Operating range 0 to 40 degrees C (32 degrees F to 104 deg. F).

Chapter 3 - Connections

3.1 – Control Diagrams

EZCL 4000 Board: 10A to 50A Units

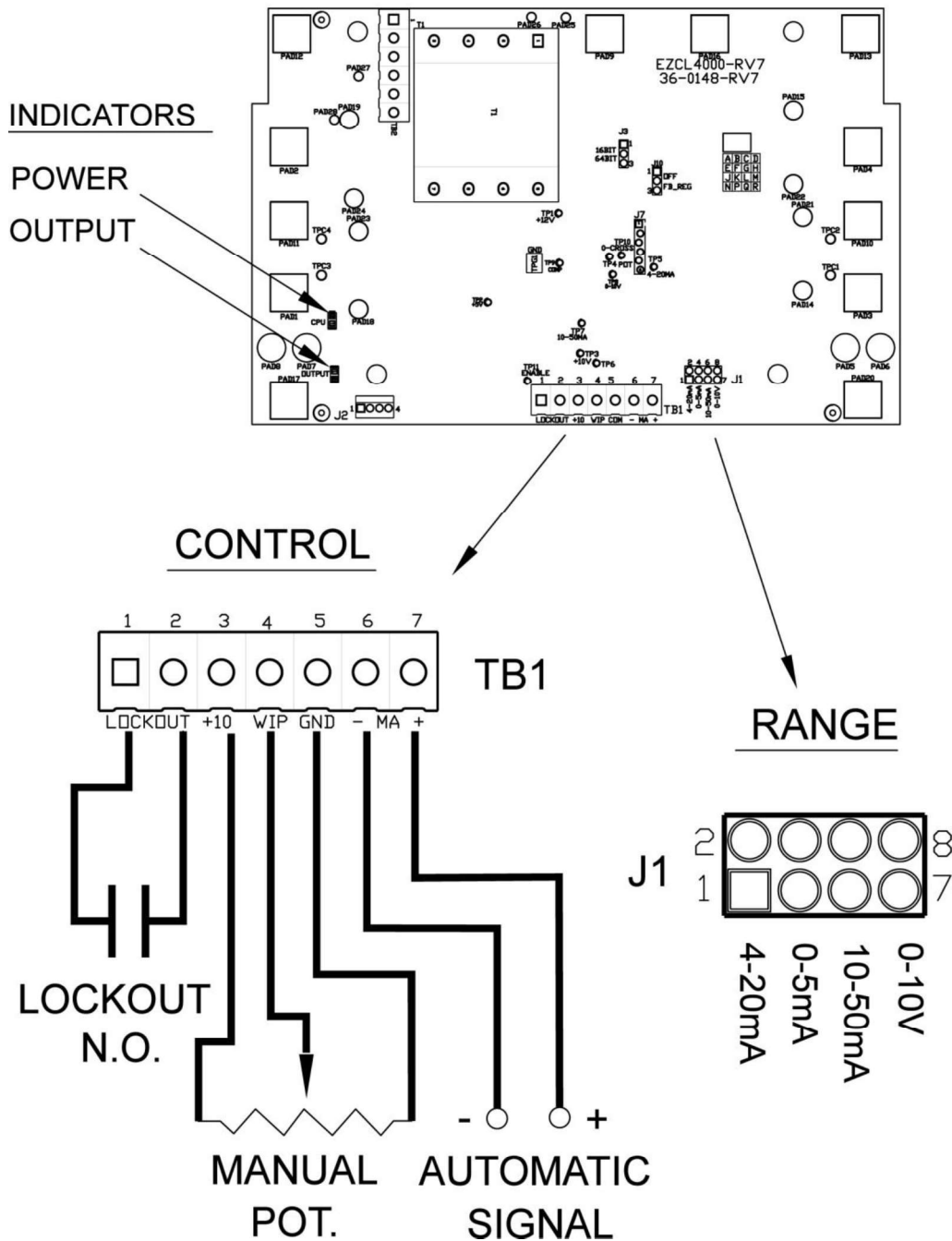

Figure 2

ZCL4000 Board: 85A and Above Units

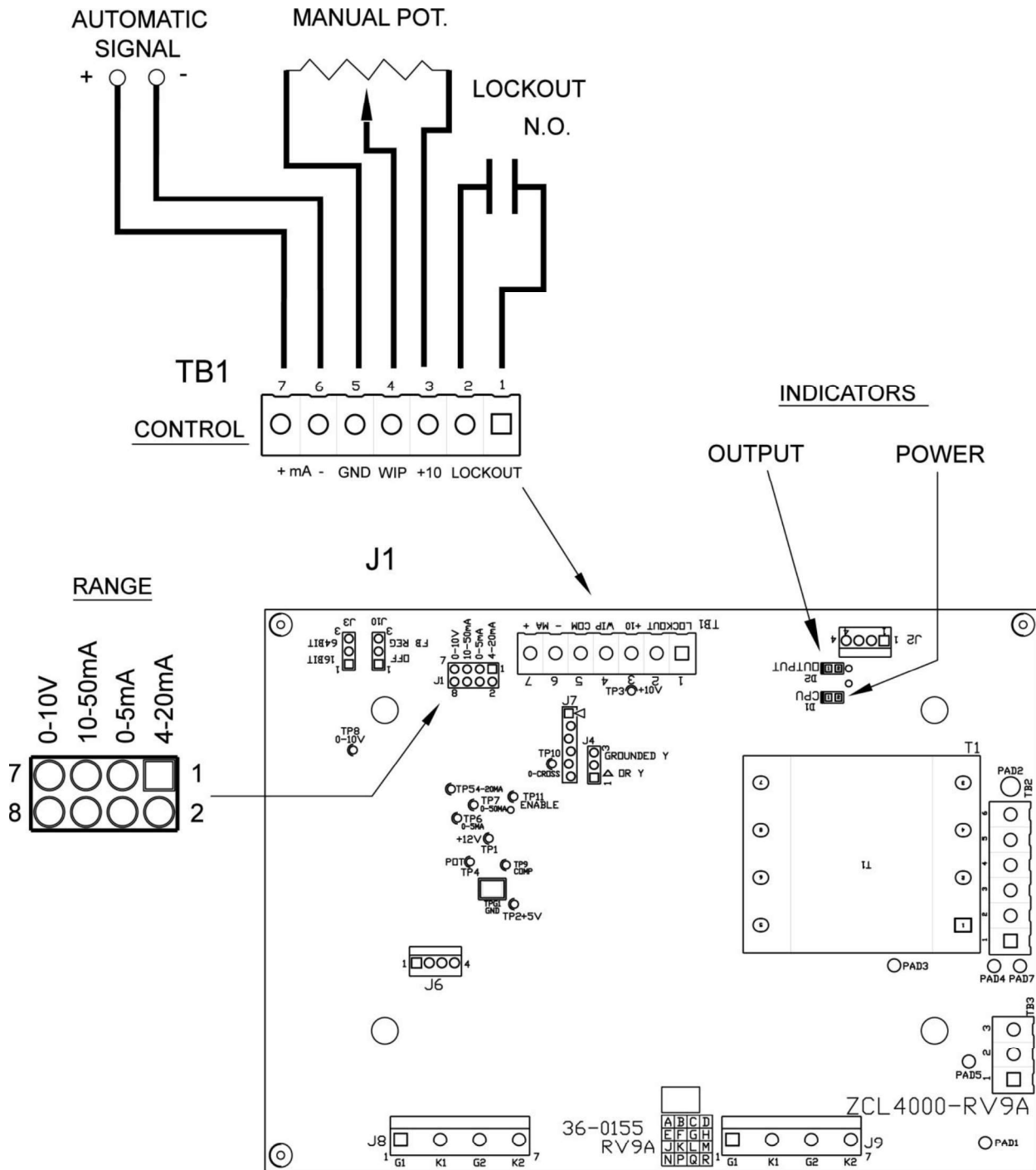

Figure 3

3.2 – Manual Control

1. If manual potentiometer is not used proceed to Automatic Control.
2. Connect manual potentiometer to terminal 3, 4 and 5 on TB1.
Terminal 3 is the High side, terminal 4 is the wiper and terminal 5 is the Low side.
3. Manual potentiometer value is 10K ohm (linear taper).
4. If you are using manual control, proceed to power connections.

3.3 – Automatic Control

1. Connect DC voltage or milliamp input signal to terminals 6 (-) and 7 (+) on TB1.
2. If manual and automatic controls are both used, consider using an external auto/manual switch to eliminate the manual setting overriding the automatic signal. See figure 4 for suggested connections.
3. Check "J1" plug for correct position to match your automatic control signal. The unit is shipped with the jumper in the 4-20 mA position. See figure 2 or 3, depending on your unit.
4. LED's are located on the board. These can be connected to remote location. See appendix A1 Connector J2 for mating connector part number. The CPU LED indicates power is on and the microprocessor is ready. The Output LED will blink when output is occurring. The frequency of the blinking follows the output voltage.

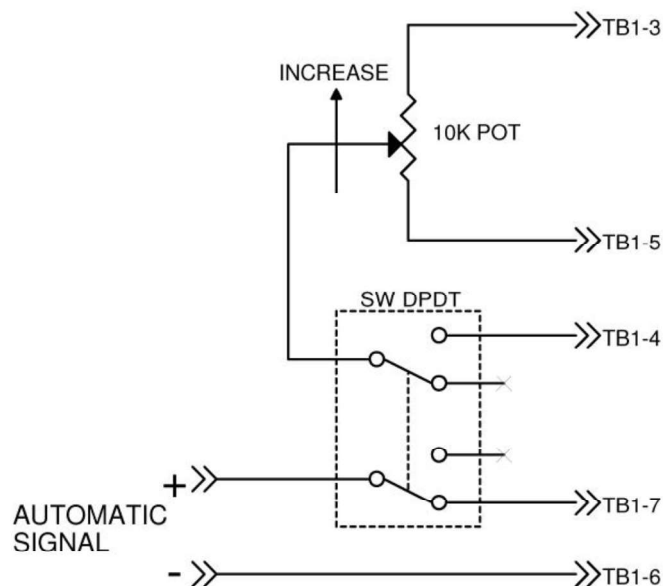
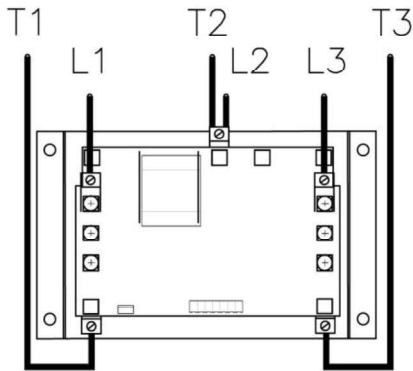

Figure 4

3.4 – Power Connections

All power wire must be sized according to local and national electrical codes.

10 to 25A



10 to 25A
with fuses

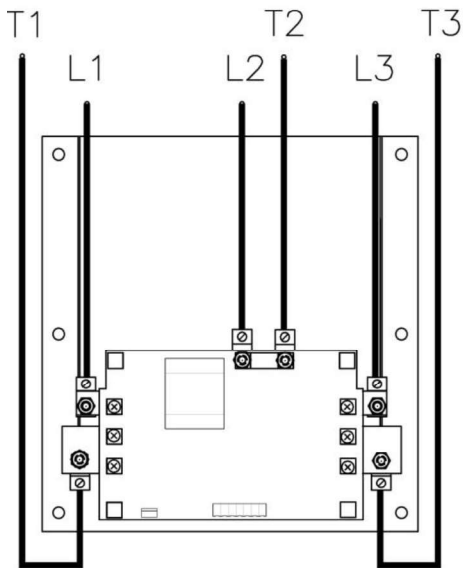
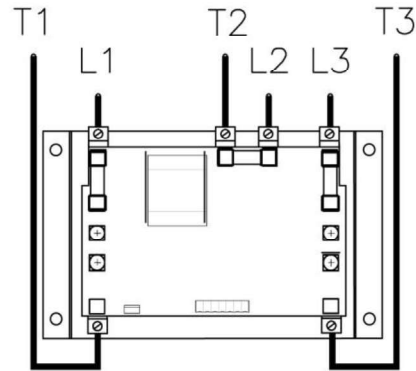

50A

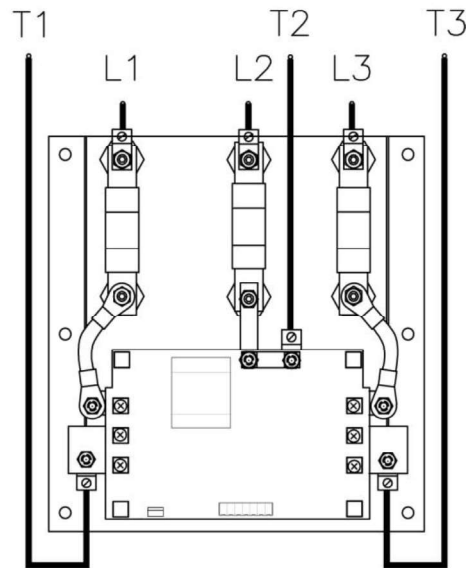

50A
with fuses

85 to 100A

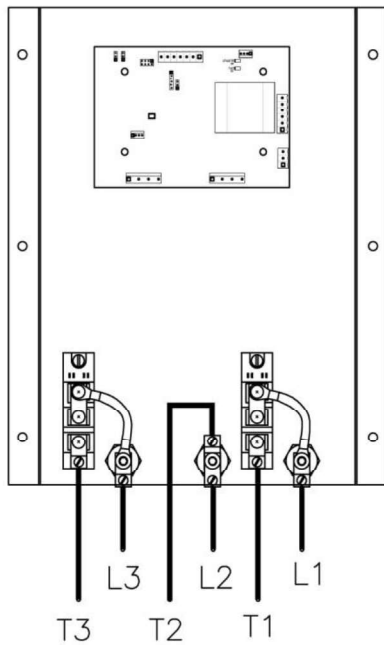

85 to 100A with fuses

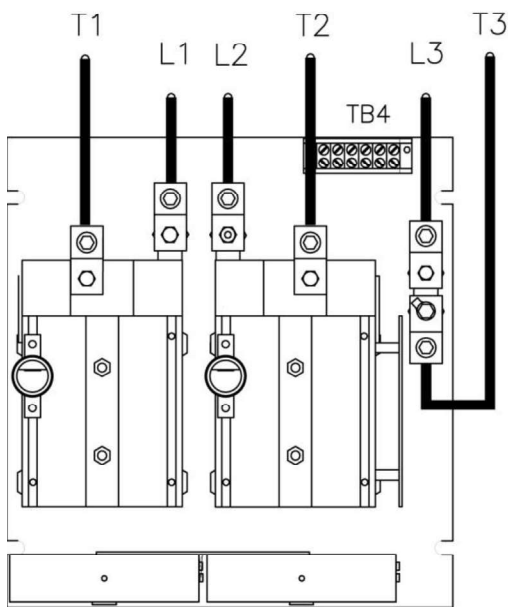
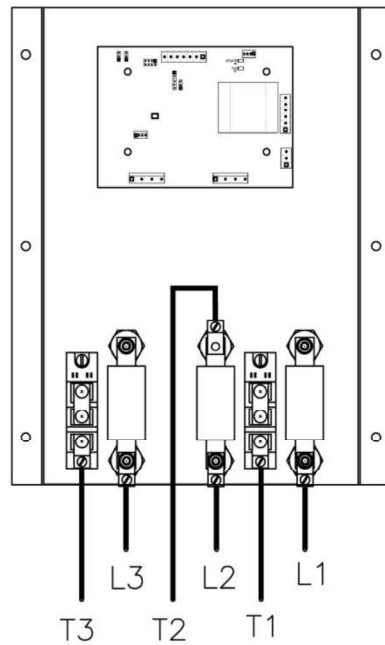

150 to 350A no fuses

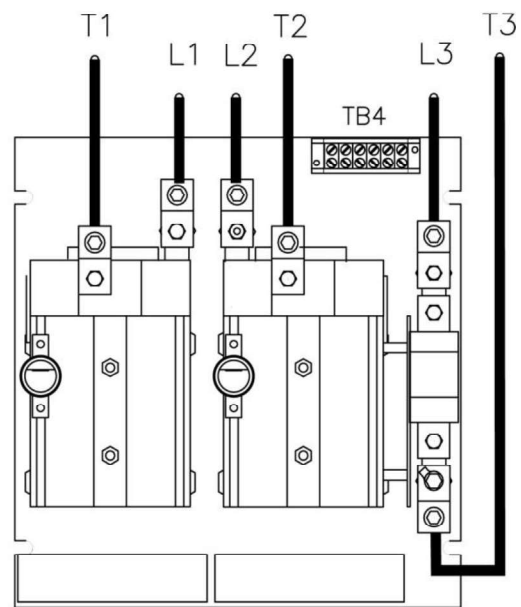

150 to 350A with fuses

150A : no fans & no TB3 , 225A & 350A : with fans & TB3

z

500 to 650A

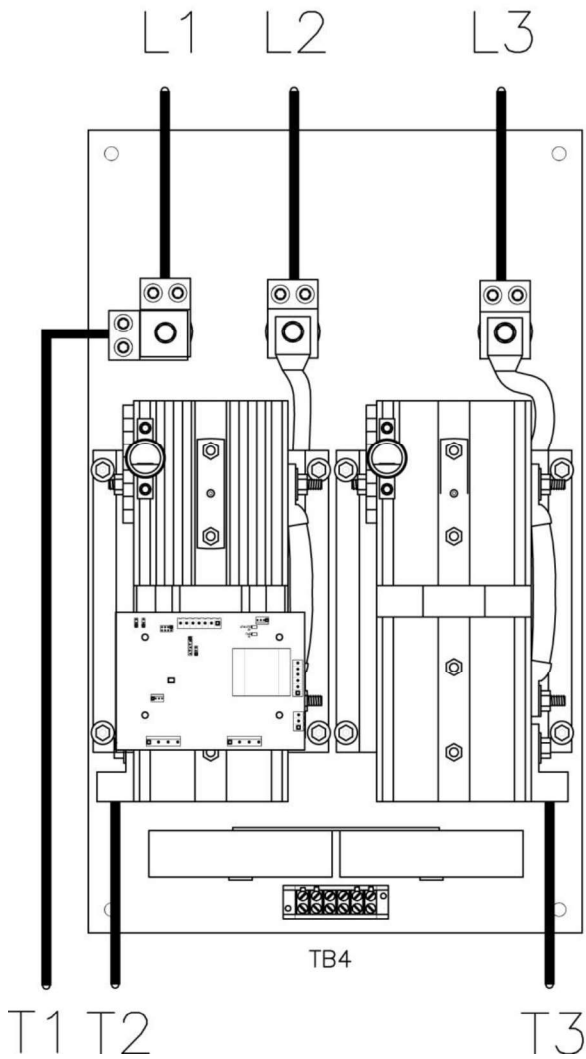

500 to 650A
with fuses

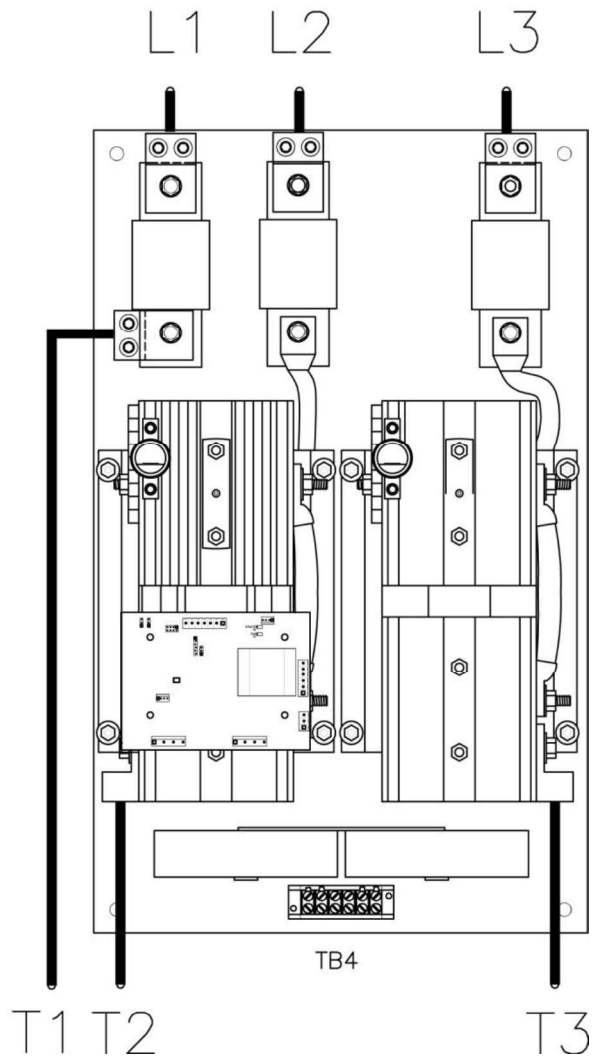

800 to 1000A

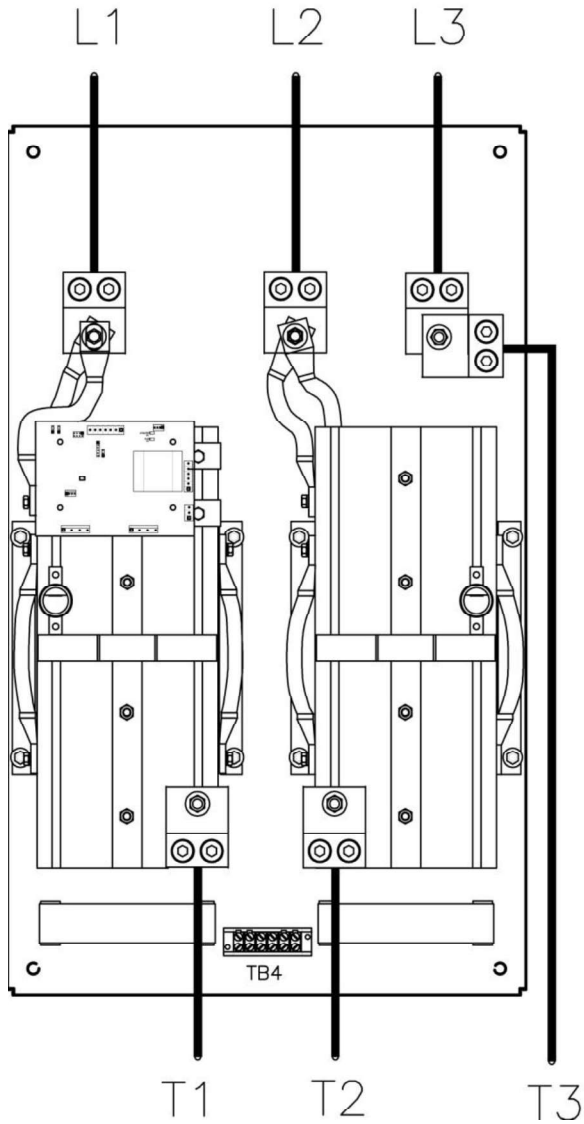

800 to 1000A with fuses

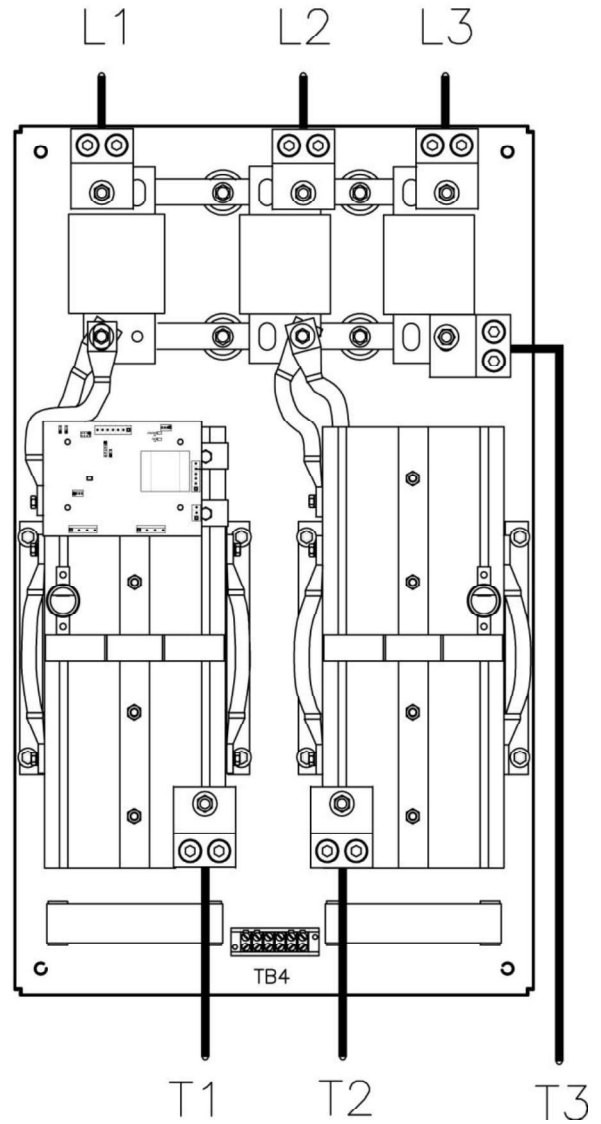

3.5 – Other Connections

1. Fans are used on 225A units and larger. 120Vac must be supplied to terminals 1 and 2 of TB4 terminal block, located on metal plate on fan units. See figure 5.
2. On 225A units and larger, TB4 pins 5 and 6 can be used as external lockout.

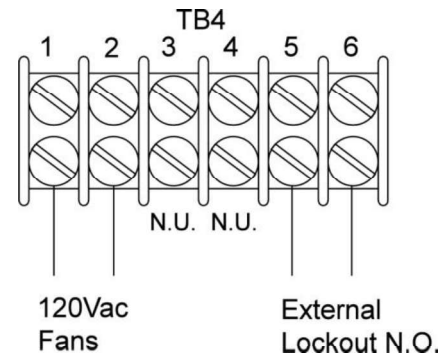

Figure 5

Chapter 4 – Start-up Procedure

4.1 – Manual Control

1. If the unit uses both automatic and manual control signals, set the automatic signal to minimum (Zero).
2. Apply power to the unit.
3. Slowly rotate manual control potentiometer. Output voltage should slowly increase with potentiometer rotation. The output duty cycle will be proportional to the voltage on TB1 pin 4.
4. If output appears to be normal, turn the manual control fully off.
5. Remove power.

4.2 – Automatic Control

1. Verify the selection of the J1 select jumper matches your input signal. (See chapter 3)
2. Apply power to the unit.
3. Slowly increase the Automatic signal input to maximum. Output voltage should slowly increase proportionally to the input signal.
4. If output appears to be normal, turn the automatic control fully off.
5. Remove power.

Note: If both automatic and manual inputs are used without the manual/automatic switch (Figure 4), then whichever of the two input signals is greater will control the unit.

Chapter 5 – Dimensions

5.1 – Unit Dimensions

EZ2 Dimensions 10 to 100A

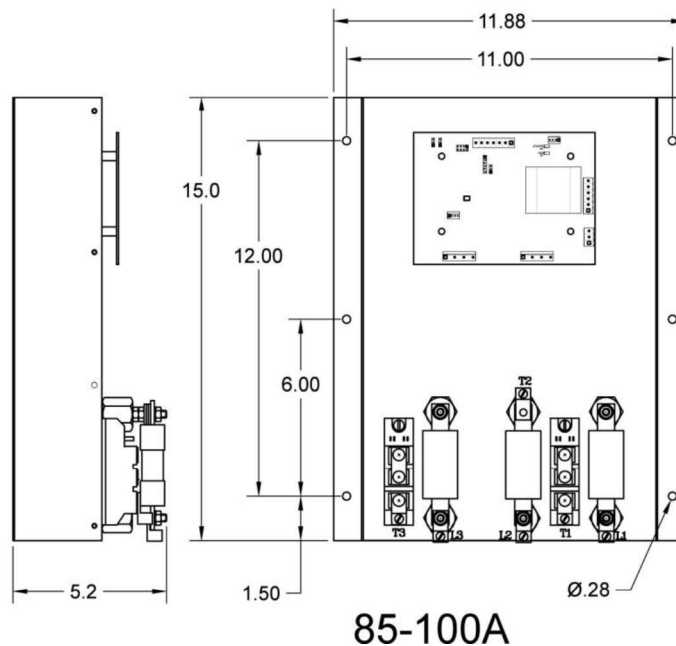
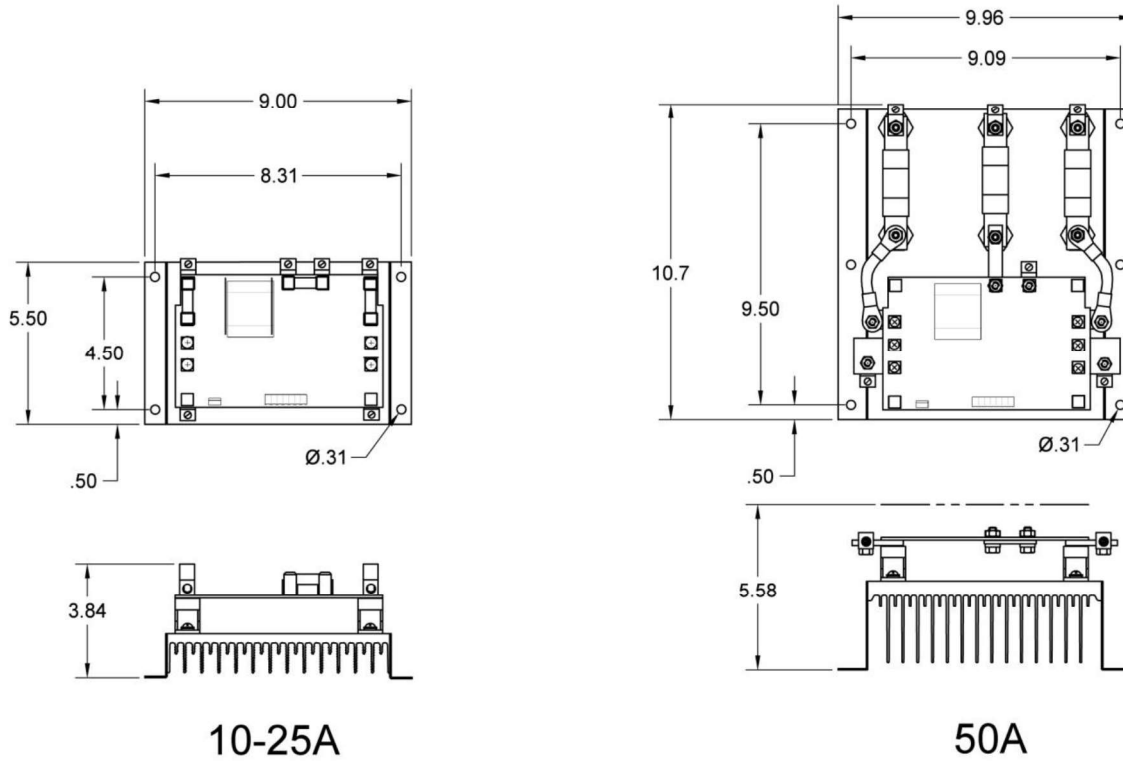

EZ2 Dimensions 150 to 650A

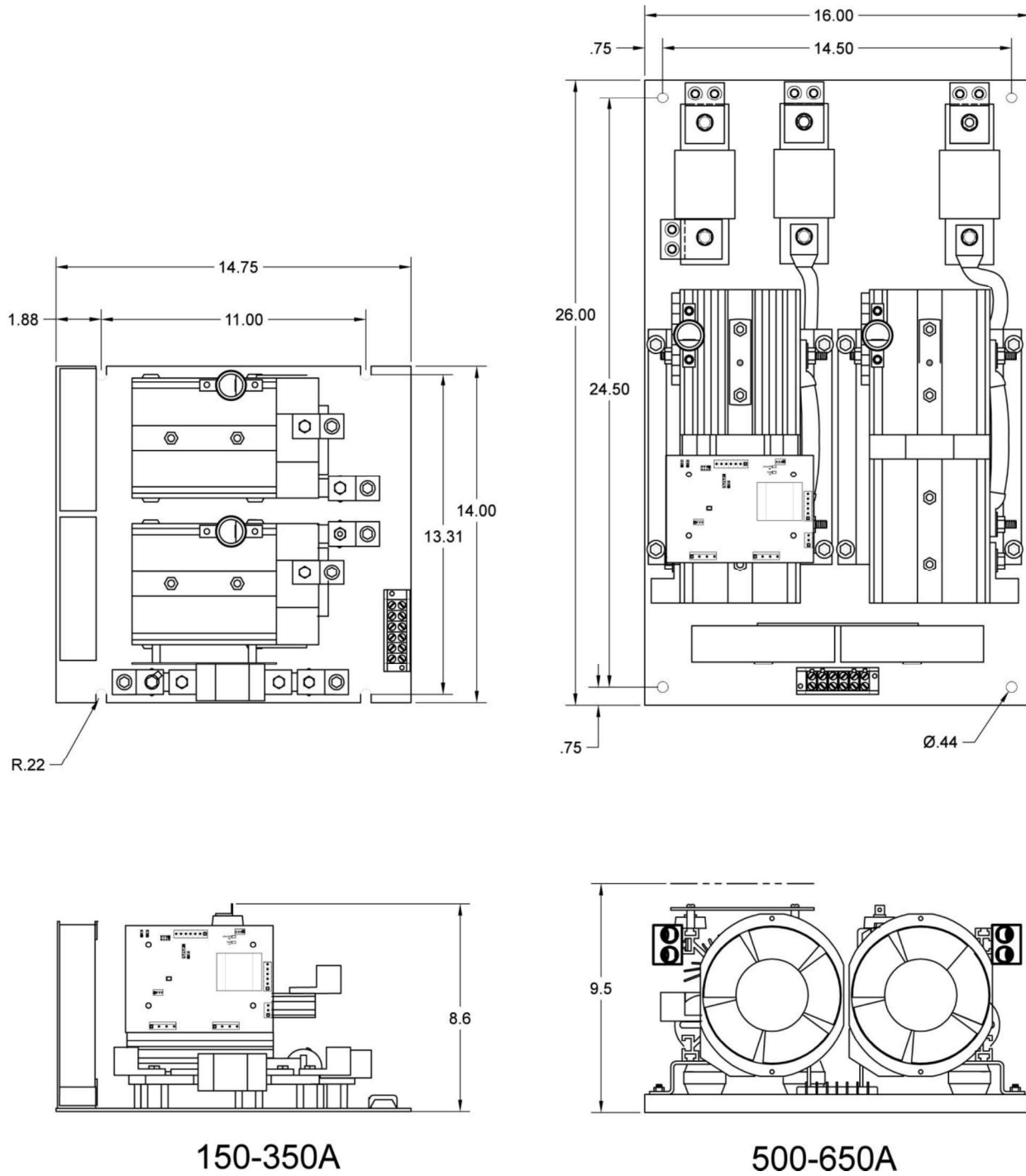

EZ2 Dimensions 800 and 1000A

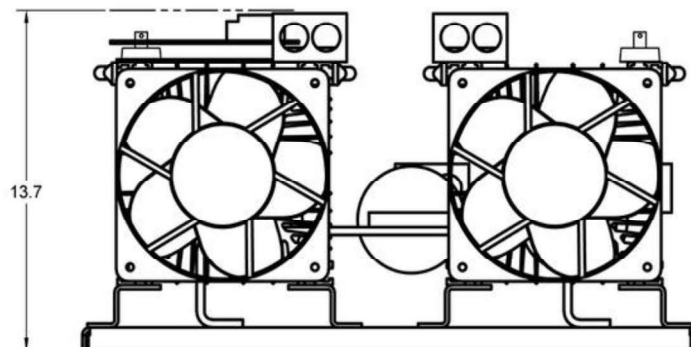
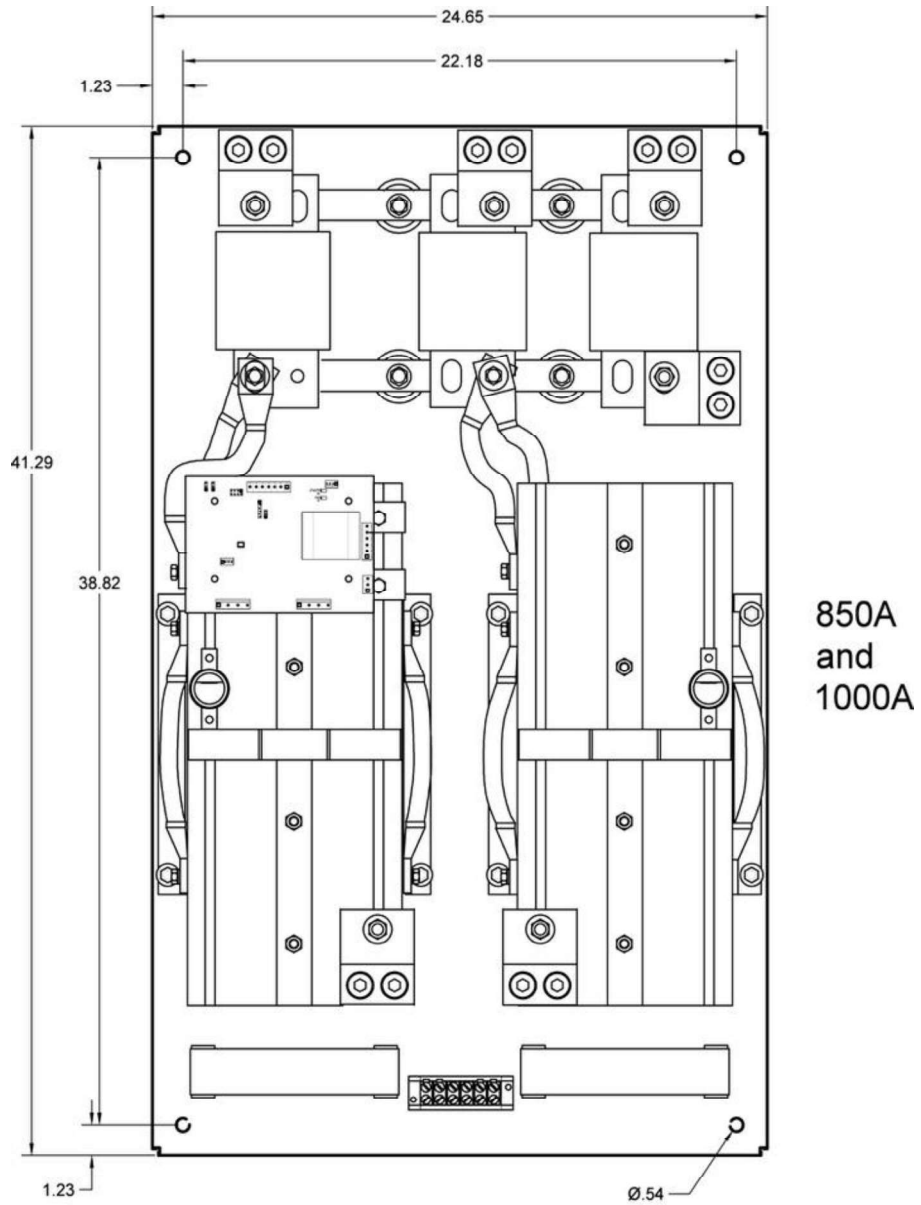

Appendix

A1 – EZCL and ZCL Board Connectors, Jumpers and Test Points

Connectors:

TB1: Pins 1 and 2 = Thermostat Inhibit Input. Factory wired to thermostat.
Pins can also be paralleled with an external N.O. dry contact as a remote inhibit.

Pins 3, 4 and 5 = Potentiometer connections for adjusting output.

Pin 3: Hi side of Potentiometer (+)
Pin 4: Wiper of Potentiometer
Pin 5: Low side of Potentiometer (-)

Pins 6 and 7 = Voltage or current automatic input. See section 3.1 thru 3.4.

Pin 6: Negative Input
Pin 7: Positive Input

TB3: Line 2 (Sensing) connection. Only on ZCL4000, factory wired

Pin 1: Not used
Pin 2: Connect to Phase 2 Line side.
Pin 3: Not Used

J2: External LED Connector

Mating Connector: TE AMP # 640456-4

Pin 1: Output LED Anode
Pin 2: CPU LED Anode
Pin 3: CPU LED Cathode
Pin 4: Output LED Cathode

Each LED current is limited to about 3.5mA on PCB. Use high efficiency LED's.

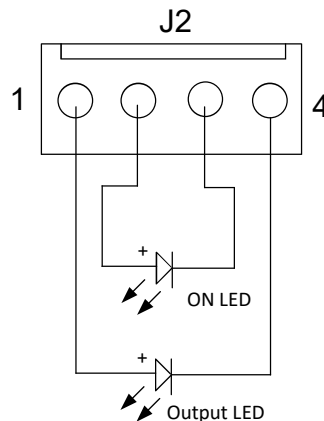

J7: Factory use only

J8: SCR Gate/Cathode connections phase B on ZCL4000, factory wired.

J9: SCR Gate/Cathode connections phase A on ZCL4000, factory wired.

Jumpers / Selections:

TB2: Transformer Voltage Selection Factory wired for ordered voltage. DO NOT REWIRE.

J1: Control Voltage or Current Input. Select with Jumper:

1-2: 4-20mA
3-4: 0-5mA
5-6: 10-50mA
7-8: 0-10V

J3: Time Base select Jumper.

1-2: 16 Cycle Time Base
2-3: 64 Cycle Time Base

Output Time Base is factory set to 64 cycles. If the 16 cycle time base is needed to match the legacy EZ series controller, move the jumper to positions 1 & 2.

J7: Factory use only.

J10: Reserved for future use.

Test Points

TPG1: Ground (this is NOT earth GND)

TP1: +12Vdc
TP2: +5Vdc
TP3: +10Vdc

A2 – Replacement Parts

EZ-2 REPLACEMENT PARTS			
Amp Rating	SCR Devices Part Number	Fuse Amp Rating	Fuse Part Number
10	25-0090-1500SD	15	52-0015-0600CC
25	25-0090-1500SD	30	52-0030-0600
50	25-0090-1500SD	60	52-0060-0700
85	25-0090-1500SD	100	52-0100-0700
100	25-0160-1600SD	125	52-0125-0700
150	25-0570-1800	175	52-0175-0700
225	25-0570-1800	250	52-0250-0700
350	25-0570-1800	400	52-0400-0700
500	25-1130-1800	600	52-0600-0700
650	25-3500-1800	700	52-0700-0700
800	25-3500-1800	900	52-0900-0700
1000	25-3500-1800	1200	52-1200-0700
-	-	2 (Fans)	52-0002-0600CC

EZ-2 REPLACEMENT BOARDS		
Voltage	10A to 100A Board Number	150A to 1000A Board Number
120V	EZCL4000-120	ZCL4000-120
208V	EZCL4000-208	ZCL4000-208
240V	EZCL4000-240	ZCL4000-240
380V	EZCL4000-380	ZCL4000-380
415V	EZCL4000-415	ZCL4000-415
480V	EZCL4000-480	ZCL4000-480
575V	EZCL4000-575	ZCL4000-575

A3 – EZ2 Model Selection Guide

MODEL SELECTION GUIDE

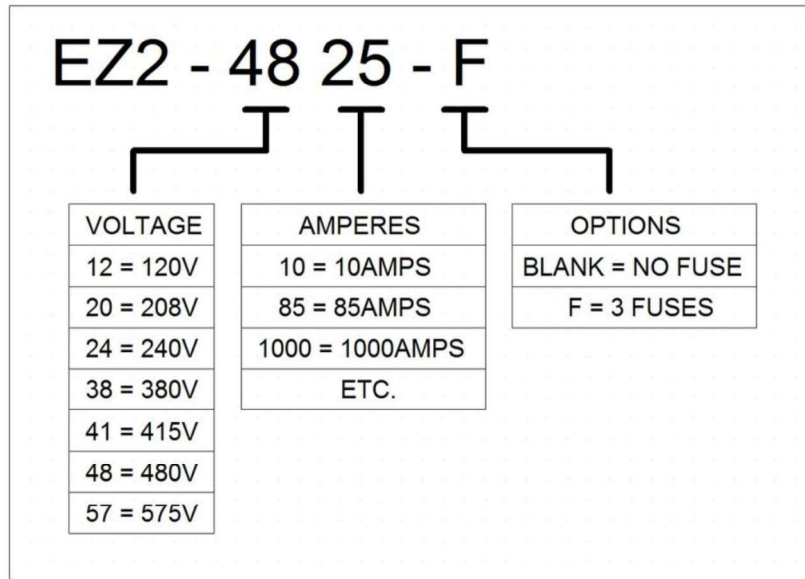

Warranty Information

Phasetronics warrants its products to be free from defects in material and/or workmanship for a period of one year from date of installation, to a maximum of 18 months from the date of shipment as indicated by the unit's date code. The Company reserves the right to repair or replace any malfunctioning units under warranty at their option. All warranty repairs must be performed by the Company factory or on site by a factory authorized service firms or personnel approved by the Company.

Solid state controls have different operation characteristics from those of electro-mechanical equipment. Because of these differences and the wide variety of applications for solid state controls, each application designer must verify that the solid-state equipment is acceptable for his application. In no event will Phasetronics be responsible or liable for indirect or consequential damages resulting from the use or application of this equipment. The diagrams and illustrations in this document are included solely for illustrative purposes. Because of the number of different applications, Phasetronics cannot be responsible or liable for actual use based on the examples or diagrams.

California Customers:

California Proposition 65 Warning

WARNING: this product and associated accessories may contain chemicals known to the State of California to cause cancer, birth defects, or other reproductive harm. For more information visit <https://p65warnings.ca.gov>



Phasetronics Inc.
1600 Sunshine Drive
Clearwater, Florida 33765
USA

Tel: +1 727.573.1900
Fax: +1 727.573.1803

www.phasetronics.com