

Circulation Heaters



WATROD™ and FIREBAR® Circulation Heaters

Circulation heaters provide a ready-made means to install electric heating with a minimal amount of time and labor. This is accomplished by combining heating elements, vessel, insulation, terminal enclosure, mounting brackets and inlet and outlet connections into a complete assembly.

Made from NPT screw plug or ANSI flange heater assemblies mated with a pressure vessel (tank), circulation heaters are designed to heat forced-circulation air, gases or liquids. Ideal for either in-line or side-arm operations, these assemblies direct fluids past FIREBAR® or WATROD™ heating elements, to deliver fast response and even heat distribution.

Watlow® meets virtually all your circulation heater assembly needs with made-to-order units. These units can be made from a wide range of heating element sheath materials, wattages, vessel sizes and materials, pressure ratings, terminal enclosures and controls.

Performance Capabilities

- Watt densities up to 120 W/in² (18.6 W/cm²)
- Wattages up to three megawatts
- UL® and CSA component recognition up to 690VAC
- Ratings up to ANSI Class 300 pressure class
- Alloy 800/840 sheath temperatures up to 1600°F (870°C)
- Passivated 316 stainless steel sheath temperatures up to 1200°F (650°C)
- Steel sheath temperatures up to 750°F (400°C)

Features and Benefits

Catalog screw plug and flange part numbers

- Provides a wide selection of WATROD and FIREBAR elements to meet specific application requirements

Type	Sizes (in.)
NPT Screw Plugs	1 1/4, 2 1/2
ANSI flanges	3, 4, 5, 6, 8, 10, 12, 14

ANSI B16.5, Class 150 on 3 to 14 inch WATROD element flanges

- Meets recognized agency standards

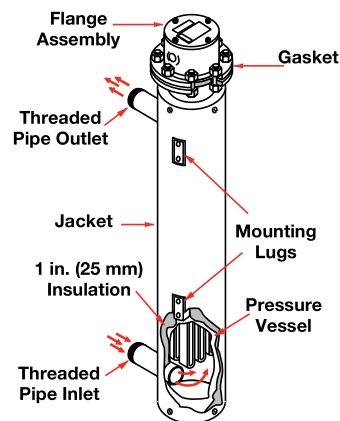
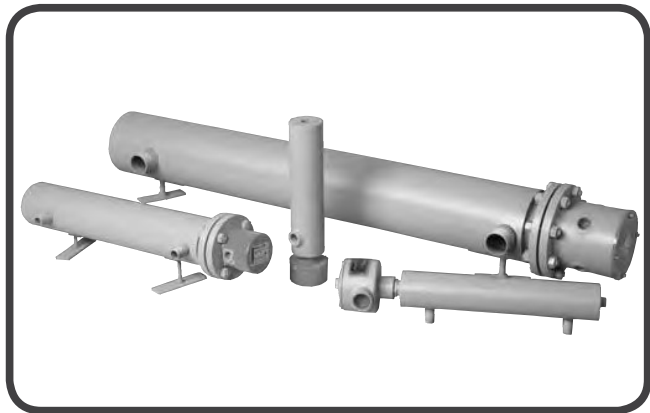

Compacted MgO insulation filled elements

- Maximizes dielectric strength, heat transfer and life

1 inch (25 mm) thermal insulation rated to 750°F (400°C)

- Reduces heat loss from the vessel

Heavy-gauge steel jacket (shroud)

- Protects thermal insulation and heating vessel and comes with protective primer coating



Circulation Heaters

WATROD and FIREBAR Circulation Heaters

Features and Benefits *(Continued)*

All catalog units rated to ANSI pressure Class 150

- Provides pressure vessels (tanks) that are either carbon or 316 stainless steel

Standard offering includes units rated for up to and including ANSI pressure class (application review required)

- Provides pressure vessels (tanks) available in carbon steel, 304 or 316 stainless steel materials
- Includes schedule 40, standard and 80 pipe used in the pressure vessel construction

Catalog units provided with NPT or ANSI Class 150 nozzle connection

- Makes installation easy. Inlet and outlet nozzle connections are threaded MNPT on 8 in. (203 mm) and smaller tanks. Class 150 flanged connections on 10 in. (254 mm) and larger tanks

Mounting lugs are welded onto the tank wall of all 2 1/2 in. (64 mm) NPT and larger units

- Provides mounting support

General purpose or NEMA 4 enclosures available

- Offers easy access to terminal wiring

Flange mounting holes

- Straddles centerline to comply with industry standards

UL® and CSA component recognition under file numbers E52951 and 31388 respectively

- Meets industry safety standards

Typical Applications

Water:

- Deionized
- Demineralized
- Clean
- Potable
- Process
- Industrial water rinse tanks
- Hydraulic oil, crude, asphalt
- Lubricating oils at API specified watt densities
- Heat transfer oil
- Paraffin
- Caustic cleaners
- Nitrogen, hydrogen and other air/gas systems
- Superheating steam

Options

WATCONNECT® Standard Control Panels



WATCONNECT® standard control panels are configured to work with Watlow's circulation heaters. They are quickly configured for process heating applications and delivered within two weeks. WATCONNECT panels integrate Watlow's high-quality heater, sensor, temperature

controller and power controller products for a complete thermal solution. Normally, competitive custom panels require significantly longer lead times. The broad range of standard features allow customers to quickly configure panels for each process heater included in this catalog.

Features and Benefits

Lead times of two weeks or less

- Provides faster delivery than competition

Full documentation provided for WATCONNECT control panels at the time of quotation

- Eliminates lengthy approval process and phone calls

Incorporates Watlow's temperature and power controllers

- Provides a turnkey solution for process heating applications

Range of standard input/output (I/O) options

- Provides the user with a higher level of monitoring and control assuring an efficient and safe operation

WATCONNECT enclosure easily mounts to wall or frame

- Decreases installation time

Note: The WATCONNECT part number associated with a heater is only a suggestion. The following installation details need to be compared to panel capabilities to assure a compatible match:

- Minimum and maximum ambient temperature where panel will be installed
- Statutory and regulatory requirements at installation site
- Sun loading, if any, at installation site
- Presence of any hazardous gases, dusts or fibers, if any
- Verification of process sensor type
- Verification of limit sensor type
- Input/Output (I/O) requirements

For additional product information see the WATCONNECT landing page at www.watlow.com/watconnect. On the WATCONNECT landing page you will find a complete specification sheet along with other tools to help you properly select your control panel. If you would like to know the specific configuration of a WATCONNECT part number, please use the Product Configuration Lookup Tool on Watlow.com.

Circulation Heaters



WATROD and FIREBAR Circulation Heaters

Options (Continued)

Terminal Enclosures

General purpose terminal enclosures, without thermostats, are supplied on all Watlow circulation heaters. Moisture and explosion resistant ratings are available to meet specific application needs. For screw plug terminal enclosures, refer to page 151. For flange terminal enclosures, refer to page 226.

Stand-off Terminal Enclosures

Stand-off terminal enclosures help protect terminal enclosures against excessive temperatures. For details, refer to page 221.

ASME Pressure Vessel Code Welding

Flange or screw plug assemblies can be provided with an ASME Section VIII, Div. I pressure vessel stamp upon request.

Branch Circuits

Branch circuits are designed for 48 amperes per circuit maximum. Contact your Watlow representative for circuit requirements other than those listed in the part number tables.

Certified Enclosures

CSA, ATEX or IECEx certified enclosures protect wiring in hazardous gas environments. These terminal enclosures, covered under CSA file number 61707, ATEX certificate # SIRA 10ATEX 1155X or IECEx certificate # IECEx CSA 09.0010 are available on WATROD flange heaters. For additional information, see page 561 and 562 or contact your Watlow representative.

For products that will be installed in hazardous locations, please provide the following information:

- Operating conditions
- Minimum and maximum ambient temperatures for the installation location
- Mounting orientation
- Process temperature (°F)
- Maximum working pressure (MWP) of application (psig)
- Media being heated

Watlow must understand this information so that an appropriate design can be provided.

Thermocouples

To sense process or element sheath temperature, ASTM Type J or K thermocouples are available.

See *Screw Plug Immersion Heaters*, page 148 and *Flange Immersion Heaters*, on page 223 for details.

Thermostats

To provide process temperature control, Watlow offers optional single- and double-pole thermostats. Thermostats are typically mounted in the terminal enclosure.

See *Screw Plug Immersion Heaters*, page 147 and *Flange Immersion Heaters*, on page 222 for details.

Baffles

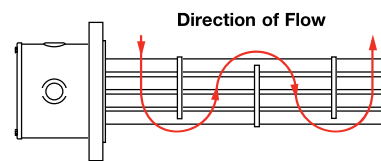

Baffles mounted on the heating element bundle enhance and/or modify liquid or gas flow for better heat transfer.

For critical sheath temperature and low flow conditions, baffles may be required.

Contact your Watlow representative for details.

Process Thermocouple in Nozzle

Note: Must specify which nozzle:

- Nozzle nearest flange or plug
- Nozzle away from flange or plug

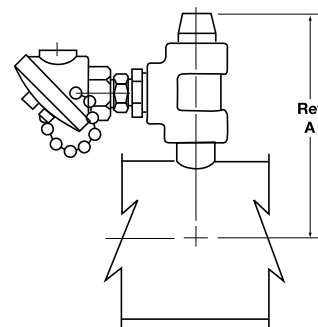

Ref. Tank Size	Ref. Nozzle Size	Dimension "A"
1 1/4	3/4 NPT	8 ³ / ₁₆
2 1/2	1 NPT	8 ³ / ₁₆
3	1 NPT	8 ³ / ₁₆
4	1 1/2 NPT	10 ³ / ₈
5	2 NPT	11 ¹ / ₁₆
6	2 1/2 NPT	13 ³ / ₈
8	2 1/2 NPT	14 ³ / ₈

For 10 in. (254 mm) and larger tanks contact your Watlow representative for dimension.



Circulation Heaters

WATROD and FIREBAR Circulation Heaters

Options (Continued)

Sheath Materials

The following sheath materials are available on WATROD and FIREBAR heating elements:

Standard Sheath Materials

WATROD	Alloy 800/840 316 SS Copper clad steel
FIREBAR	Steel Alloy 800, 304 SS

Made-to-Order Sheath Materials

WATROD	304 SS Alloy 600 Titanium Hastelloy C276 Inconel®/Steel Monel®
---------------	---

Wattages and Voltages

Watlow routinely supplies circulation heaters with 120 to 690VAC as well as wattages from 500 watts to one megawatt. If required, Watlow will configure circulation heaters with voltages and wattages outside these parameters.

For more information on special voltage and wattage configurations, contact your Watlow representative.

Pressure Vessels

All catalog pressure vessel (tank) materials consist of standard schedule and 150# class forged fittings and are made from one of the following materials:

- Carbon steel
- 316 stainless steel

All catalog pressure vessels (tanks) are steel unless otherwise noted.

316 stainless steel pressure vessels (tanks) are passivated on all wetted surfaces. Available on 2¹/₂ inch NPT and 4 or 6 inch ANSI flange circulation heaters.

Passivated Finish

For critical applications, passivation will remove free iron from all wetted surfaces.

Contact your Watlow representative for details.

Gaskets

Rubber, asbestos-free and spiral wound gaskets are available for all heater flanges, and inlet and outlet flange sizes.

Watlow recommends ordering spares in case replacement becomes necessary.

To order, specify **gasket type, flange size/rating** and **process operating temperature**.

For details on gasket materials and temperature ratings, see page 223.

Inlet and Outlet Nozzle Connections

All inlet and outlet materials are compatible with the pressure vessel material and pressure class rating.

Vessel sizes from 1¹/₄ to 8 inches are typically configured with MNPT (Male National Taper Pipe Thread) nozzles. Optional NPT and flange sizes can be supplied to mate with existing piping.

10 inch and larger vessels are supplied with Class 150 inlet and outlet flanges. Optional Class 300 or Class 600 can be provided to mate with existing piping.

To order, specify **type, size** and **pressure class** rating for both inlet and outlet nozzle/flange connections.

Protective Jacket (Shroud)

To protect circulation heaters from weather or wash-down conditions, welded (standard) outer protective jackets are available. Standard steel, or made-to-order 304 or 316 stainless steel or aluminum can be supplied. Jacket diameter is dependent upon thermal insulation thickness.

To order, specify **protective jacket, material type** and **weatherproof**, if desired.

Circulation Heaters



WATROD and FIREBAR Circulation Heaters

Technical Data

Maximum Velocities

The rate at which a gas or liquid flows through inlet and outlet pipes is critical to maintaining the desired output temperature. Pressure drop through the circulation heater must be considered to properly size blowers or pumps. The *Maximum Velocity to Avoid Excessive Pressure Drop* chart gives recommended maximum velocities, in feet per second and meters per second of gas or liquid being heated and nominal pipe size.

Maximum Velocity to Avoid Excessive Pressure Drop

Fluid	Nominal Pipe Size in.	Maximum Velocity	
		ft/sec	(m/sec)
Gases	All	200	(61.0)
Liquid	4 and smaller	10	(3.0)
Liquid	6-8	15	(5.0)
Liquid	10-12	19	(6.0)
Liquid	14-16	21	(6.4)
Liquid	18-20	23	(7.0)
Liquid	24	24	(7.3)

Vessel Orientation Guidelines

Correctly orienting the heating vessel assures lower terminal enclosure temperatures and element immersion. Detailed instructions on vessel orientation are contained in the *Installation and Maintenance Instructions* that accompanies all circulation heaters.

The following are guidelines for vessel orientation in liquid and gas heating applications.

Liquids

Orient circulation heater:

- Horizontally with inlet and outlet pipes pointing up
- Vertically with the terminal enclosure up and the inlet pipe on the bottom

These orientations ensure the heating elements will be immersed at all times and help prevent premature failure.

Air or Gases

Orient circulation heater:

- Horizontally with the inlet nozzle closest to the terminal enclosure
- Vertically with terminal enclosure at the bottom of the tank. Use the nozzle nearest the bottom as the inlet connection

If installation constraints do not allow mounting in accordance with these guidelines, contact your Watlow representative.

Application Hints

- Select the recommended heating element sheath material and watt density for the substance being heated. Use the *Supplemental Applications Chart* on pages 550 to 553. If unable to determine the correct heating element type and material, contact your Watlow representative.
- Assure selecting proper vessel by considering the pressure or flow rate, process temperature and corrosiveness of the media being heated. If assistance with vessel selection is required, contact your Watlow representative.
- For maintenance/replacement procedures, retain an area twice the circulation heater's overall length to permit easy removal and inspection of screw plug or flange heater assemblies.
- Choose a FIREBAR assembly when you require:
 - A smaller package
 - More kilowatts or lower watt density in an equally sized WATROD circulation tank
- Minimize problems associated with low flow or low liquid level conditions with a low liquid level sensor and/or sheath high-limit control.
- Ensure wiring integrity by making sure terminal enclosure temperature does not exceed 400°F (205°C).
- Size power feeder wires in accordance with National Electrical Code (NEC) guidelines and other applicable codes.
- Protect against electrical shock by properly grounding the unit per NEC requirements.
- One or more circulation heaters may be connected in series to achieve the desired total kilowatt or temperature output.

Circulation Heaters

**EXTENDED
CAPABILITY**



Extended Capabilities for WATROD and FIREBAR Circulation Heaters

Performance Capabilities

- Up to 3000psi design pressure

Features and Benefits

Offering includes units rated above ANSI pressure class 300

- Pressure vessel tanks are available in 304 and 316 “H” series stainless steel, Alloy 600, Alloy 800, Chrome Moly, Monel®, Duplex and 321 stainless steel.

Options

Exotic Sheath Materials

Contact your Watlow representative for details and availability.

Pressure Vessels

Made-to-order units can be made in a variety of materials, flange sizes and pressure classes.

To order, specify **pressure vessel (tank) size, material and pressure class.**

Ratings to ANSI class 2500 pressure class are available for high-pressure applications.

High-Temperature Thermal Insulation

To further minimize heat loss, the pressure vessel’s standard one inch thermal insulation wrap may be replaced with thicker or higher temperature insulation. For more information, contact your Watlow representative.

To order, specify **insulation thickness, standard or high temperature insulation and temperature rating.**

Vessels may be supplied with a primer coating without insulation.

To order, specify **no insulation.**

Support Saddles

To mate with an existing installation, customized support saddle(s) and/or mounting lugs are available.

To order, specify **mounting lugs or support saddles** and supply a dimensional drawing.



Circulation Heaters

WATROD and FIREBAR Circulation Heaters



Application: Clean Water[®]

- WATROD or FIREBAR elements
- Without thermostat
- General purpose enclosure

Description	Volts	kW	Ph	# Circ.	Part Number	WATCONNECT Part Number		Ship Wt. lbs (kg)	"A" Dim. in. (mm)	"N" Dim. in. (mm)	"C" Dim. in. (mm)
						Type J T/C	Type K T/C				
1 1/4 inch NPT Screw Plug (WATROD)											
60 W/in² Steel Tank 2-Alloy 800 Elements (9.3 W/cm²)	120	3.0	1	1	CBEN15A6S	C1-15	C1-12	23 (11)	24 ⁵ / ₈ (625.5)	15 (381)	3 ¹ / ₈ (79.4)
	240	3.0	1	1	CBEN15A6S	C1-17	C1-13	23 (11)	24 ⁵ / ₈ (625.5)	15 (381)	3 ¹ / ₈ (79.4)
	240	4.0	1	1	CBEN19A10S	C1-17	C1-13	29 (14)	24 ⁵ / ₈ (625.5)	15 (381)	3 ¹ / ₈ (79.4)
	240	5.0	1	1	CBEN23J10S	C/F	C/F	29 (14)	32 ⁵ / ₈ (828.7)	23 (584)	3 ¹ / ₈ (79.4)
	240	6.0	1	1	CBEN27J10S	C/F	C/F	31 (14)	32 ⁵ / ₈ (828.7)	23 (584)	3 ¹ / ₈ (79.4)
1 1/4 inch NPT Screw Plug (FIREBAR)											
90 W/in² Steel Tank 1-Alloy 800 Element (14 W/cm²)	240	1.5	1	1	CBDNF7R10S	C1-17	C1-13	26 (12)	24 ⁵ / ₈ (625.5)	15 (381)	3 ¹ / ₈ (79.4)
	480	1.5	1	1	CBDNF7R11S	C/F	C/F	26 (12)	24 ⁵ / ₈ (625.5)	15 (381)	3 ¹ / ₈ (79.4)
	240	3.0	1	1	CBDNF11G10S	C1-17	C1-13	26 (12)	24 ⁵ / ₈ (625.5)	15 (381)	3 ¹ / ₈ (79.4)
	480	3.0	1	1	CBDNF11G11S	C/F	C/F	26 (12)	24 ⁵ / ₈ (625.5)	15 (381)	3 ¹ / ₈ (79.4)
	240	5.0	3	1	CBDNF16G3S	C2-50	C2-92	26 (12)	24 ⁵ / ₈ (625.5)	15 (381)	3 ¹ / ₈ (79.4)
	480	5.0	3	1	CBDNF16G5S	C2-43	C2-35	26 (12)	24 ⁵ / ₈ (625.5)	15 (381)	3 ¹ / ₈ (79.4)
	240	6.5	3	1	CBDNF19G3S	C2-50	C2-92	30 (14)	32 ⁵ / ₈ (828.7)	23 (584)	3 ¹ / ₈ (79.4)
	480	6.5	3	1	CBDNF19G5S	C2-43	C2-35	30 (14)	32 ⁵ / ₈ (828.7)	23 (584)	3 ¹ / ₈ (79.4)
	240	8.5	3	1	CBDNF24L3S	C2-50	C2-92	31 (14)	32 ⁵ / ₈ (828.7)	23 (584)	3 ¹ / ₈ (79.4)
	480	8.5	3	1	CBDNF24L5S	C2-43	C2-35	31 (14)	32 ⁵ / ₈ (828.7)	23 (584)	3 ¹ / ₈ (79.4)
	240	10.5	3	1	CBDNF29R3S	C2-236	C2-214	43 (20)	42 ⁵ / ₈ (1082.7)	32 (813)	4 ³ / ₈ (111.1)
	480	10.5	3	1	CBDNF29R5S	C2-43	C2-35	43 (20)	42 ⁵ / ₈ (1082.7)	32 (813)	4 ³ / ₈ (111.1)
	240	12.7	3	1	CBDNF34R3S	C2-236	C2-214	44 (20)	42 ⁵ / ₈ (1082.7)	32 (813)	4 ³ / ₈ (111.1)
	480	12.7	3	1	CBDNF34R5S	C2-43	C2-35	44 (20)	42 ⁵ / ₈ (1082.7)	32 (813)	4 ³ / ₈ (111.1)
	240	17.0	3	1	CBDNF45G3S	C2-236	C2-214	69 (32)	63 ⁵ / ₈ (1616.1)	53 (1346)	4 ³ / ₈ (111.1)
	480	17.0	3	1	CBDNF45G5S	C2-43	C2-35	69 (32)	63 ⁵ / ₈ (1616.1)	53 (1346)	4 ³ / ₈ (111.1)
	480	21.5	3	1	CBDNF55R5S	C2-225	C2-226	71 (33)	63 ⁵ / ₈ (1616.1)	53 (1346)	4 ³ / ₈ (111.1)
2 1/2 inch NPT Screw Plug (WATROD)											
60 W/in² Steel Tank 3-Alloy 800 Elements (9.3 W/cm²)	240	6.0	3	1	CBLN714L3S	C2-50	C2-92	24 (11)	34 ³ / ₄ (881)	22 ¹ / ₂ (572)	16 ¹ / ₂ (419)
	480	6.0	3	1	CBLN714L5S	C2-43	C2-35	24 (11)	34 ³ / ₄ (881)	22 ¹ / ₂ (572)	16 ¹ / ₂ (419)
	240	7.5	3	1	CBLN717L3S	C2-50	C2-92	24 (11)	34 ³ / ₄ (881)	22 ¹ / ₂ (572)	16 ¹ / ₂ (419)
	480	7.5	3	1	CBLN717L5S	C2-43	C2-35	24 (11)	34 ³ / ₄ (881)	22 ¹ / ₂ (572)	16 ¹ / ₂ (419)
	240	9.0	3	1	CBLN720L3S	C2-50	C2-92	26 (12)	34 ³ / ₄ (881)	22 ¹ / ₂ (572)	16 ¹ / ₂ (419)
	480	9.0	3	1	CBLN720L5S	C2-43	C2-35	26 (12)	34 ³ / ₄ (881)	22 ¹ / ₂ (572)	16 ¹ / ₂ (419)
	240	12.0	3	1	CBLN726C3S	C2-236	C2-214	27 (13)	44 ³ / ₄ (1135)	32 ¹ / ₂ (826)	26 ¹ / ₂ (673)
	480	12.0	3	1	CBLN726C5S	C2-43	C2-35	27 (13)	44 ³ / ₄ (1135)	32 ¹ / ₂ (826)	26 ¹ / ₂ (673)
	240	15.0	3	1	CBLN731L3S	C2-236	C2-214	29 (14)	44 ³ / ₄ (1135)	32 ¹ / ₂ (826)	26 ¹ / ₂ (673)
	480	15.0	3	1	CBLN731L5S	C2-43	C2-35	29 (14)	44 ³ / ₄ (1135)	32 ¹ / ₂ (826)	26 ¹ / ₂ (673)
	240	18.0	3	1	CBLN737C3S	C2-236	C2-214	30 (14)	57 ¹ / ₄ (1453)	45 (1143)	39 (991)
	480	18.0	3	1	CBLN737C5S	C2-43	C2-35	30 (14)	57 ¹ / ₄ (1453)	45 (1143)	39 (991)

1 1/4 inch NPT Screw Plug

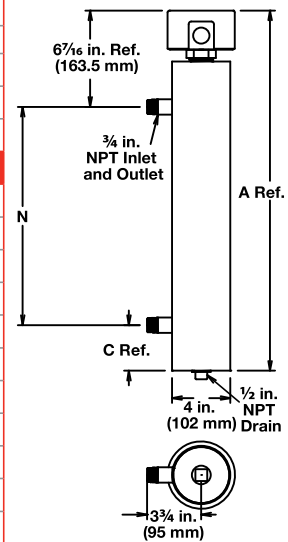

2 1/2 inch NPT Screw Plug

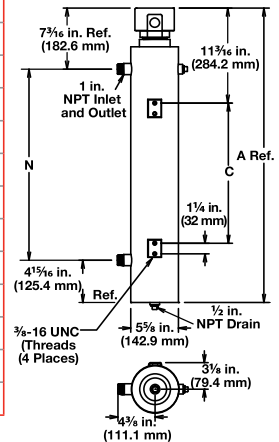

④ Wired for higher voltage

⑤ When steel vessel materials are used in this application, some rust may be present in the process media

C/F - Contact factory, go to www.watlow.com/en/contact-us





Circulation Heaters

WATROD and FIREBAR Circulation Heaters



Application: Clean Water®

- WATROD or FIREBAR elements
- Without thermostat
- General purpose enclosure

Description	Volts	kW	Ph	# Circ.	Part Number	WATCONNECT Part Number		Ship Wt. lbs (kg)	"A" Dim. in. (mm)	"N" Dim. in. (mm)	"C" Dim. in. (mm)
						Type J T/C	Type K T/C				
2 1/2 inch NPT Screw Plug (FIREBAR)											
90 W/in²® Steel Tank 3-Alloy 800 Elements (14 W/cm²)	240	15.0	3	1	CBLNF15C3S	C2-236	C2-214	22 (10)	34 ³ / ₄ (881)	22 ¹ / ₂ (572)	16 ¹ / ₂ (419)
	480	15.0	3	1	CBLNF15C5S	C2-43	C2-35	22 (10)	34 ³ / ₄ (881)	22 ¹ / ₂ (572)	16 ¹ / ₂ (419)
	240	20.0	3	1	CBLNF18C3S	C2-236	C2-214	23 (11)	34 ³ / ₄ (881)	22 ¹ / ₂ (572)	16 ¹ / ₂ (419)
	480	20.0	3	1	CBLNF18C5S ^③	C2-43	C2-35	23 (11)	34 ³ / ₄ (881)	22 ¹ / ₂ (572)	16 ¹ / ₂ (419)
	480	25.0	3	1	CBLNF23C5S	C2-225	C2-226	31 (14)	34 ³ / ₄ (881)	22 ¹ / ₂ (572)	16 ¹ / ₂ (419)
	480	32.0	3	1	CBLNF28L5S	C2-225	C2-226	34 (16)	44 ³ / ₄ (1135)	32 ¹ / ₂ (826)	26 ¹ / ₂ (673)
480	38.0	3	1	CBLNF33L5S	C2-225	C2-226	35 (16)	44 ³ / ₄ (1135)	32 ¹ / ₂ (826)	26 ¹ / ₂ (673)	
3 inch - 150 lb ANSI Flange (WATROD)											
60 W/in² Steel Tank 3-Alloy 800 Elements (9.3 W/cm²)	120	6.0	1	1	CFMN715J10S	C/F	C/F	66 (30)	35 ¹ / ₄ (894)	22 ¹ / ₂ (573)	16 ¹ / ₂ (419)
	240	6.0	3	1	CFMN715J3S	C2-50	C2-92	66 (30)	35 ¹ / ₄ (894)	22 ¹ / ₂ (573)	16 ¹ / ₂ (419)
	480	6.0	1	1	CFMN715J11S	C/F	C/F	66 (30)	35 ¹ / ₄ (894)	22 ¹ / ₂ (573)	16 ¹ / ₂ (419)
	480	6.0	3	1	CFMN715J5S	C2-43	C2-35	66 (30)	35 ¹ / ₄ (894)	22 ¹ / ₂ (573)	16 ¹ / ₂ (419)
	120	9.0	1	1	CFMN721J10S	C/F	C/F	70 (32)	35 ¹ / ₄ (894)	22 ¹ / ₂ (573)	16 ¹ / ₂ (419)
	240	9.0	3	1	CFMN721J3S	C2-50	C2-92	70 (32)	35 ¹ / ₄ (894)	22 ¹ / ₂ (573)	16 ¹ / ₂ (419)
	480	9.0	1	1	CFMN721J11S	C/F	C/F	70 (32)	35 ¹ / ₄ (894)	22 ¹ / ₂ (573)	16 ¹ / ₂ (419)
	480	9.0	3	1	CFMN721J5S	C2-43	C2-35	70 (32)	35 ¹ / ₄ (894)	22 ¹ / ₂ (573)	16 ¹ / ₂ (419)
	240	12.0	3	1	CFMN727A3S	C2-236	C2-214	80 (37)	45 ¹ / ₄ (1148)	32 ¹ / ₂ (826)	26 ¹ / ₂ (673)
	480	12.0	1	1	CFMN727A11S	C/F	C/F	80 (37)	45 ¹ / ₄ (1148)	32 ¹ / ₂ (826)	26 ¹ / ₂ (673)
	480	12.0	3	1	CFMN727A5S	C2-43	C2-35	80 (37)	45 ¹ / ₄ (1148)	32 ¹ / ₂ (826)	26 ¹ / ₂ (673)
	240	15.0	3	1	CFMN732J3S	C2-236	C2-214	96 (44)	45 ¹ / ₄ (1148)	32 ¹ / ₂ (826)	26 ¹ / ₂ (673)
	480	15.0	1	1	CFMN732J11S	C/F	C/F	96 (44)	45 ¹ / ₄ (1148)	32 ¹ / ₂ (826)	26 ¹ / ₂ (673)
	480	15.0	3	1	CFMN732J5S	C2-43	C2-35	96 (44)	45 ¹ / ₄ (1148)	32 ¹ / ₂ (826)	26 ¹ / ₂ (673)
	240	18.0	3	1	CFMN738A3S	C2-236	C2-236	98 (45)	57 ³ / ₄ (1465)	45 (1143)	39 (991)
	480	18.0	1	1	CFMN738A11S	C/F	C/F	98 (45)	57 ³ / ₄ (1465)	45 (1143)	39 (991)
	480	18.0	3	1	CFMN738A5S	C2-43	C2-35	98 (45)	57 ³ / ₄ (1465)	45 (1143)	39 (991)

2 1/2 inch NPT Screw Plug

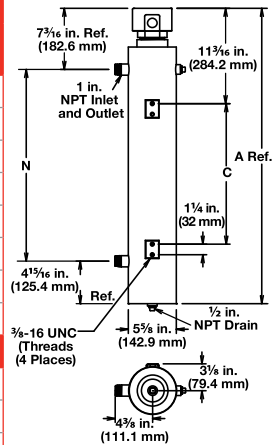

3 inch - 150 lb ANSI Flange

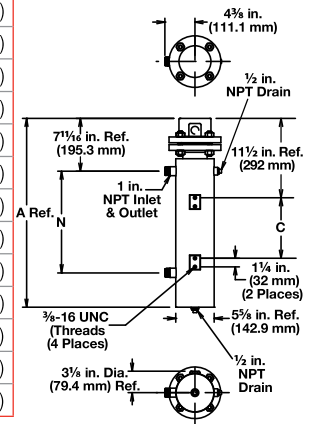

③ Wired for 3-phase operation only

⑤ When steel vessel materials are used in this application, some rust may be present in the process media

⑥ Can be wired for 1-phase operation

C/F - Contact factory, go to www.watlow.com/en/contact-us

Circulation Heaters



WATROD and FIREBAR Circulation Heaters

Application: Clean Water®

- WATROD elements
- Without thermostat
- General purpose enclosure

Description	Volts	kW	# Ph Circ.	Part Number	WATCONNECT Part Number		Ship Wt. lbs (kg)	"A" Dim. in. (mm)	"N" Dim. in. (mm)	"C" Dim. in. (mm)	
					Type J T/C	Type K T/C					
4 inch - 150 lb ANSI Flange (WATROD)											
60 W/in² Steel Tank 6-Alloy 800 Elements (9.3 W/cm²)	240	12.0	1	2	CFON715J10S	C/F	C/F	124 (57)	39 (989)	20 ¹ / ₂ (521)	17 (432)
	240	12.0	3	1	CFON715J3S	C2-236	C2-214	124 (57)	39 (989)	20 ¹ / ₂ (521)	17 (432)
	480	12.0	1	1	CFON715J11S	C/F	C/F	124 (57)	39 (989)	20 ¹ / ₂ (521)	17 (432)
	480	12.0	3	1	CFON715J5S	C2-43	C2-35	124 (57)	39 (989)	20 ¹ / ₂ (521)	17 (432)
	240	18.0	1	2	CFON721J10S	C/F	C/F	127 (58)	39 (989)	20 ¹ / ₂ (521)	17 (432)
	240	18.0	3	1	CFON721J3S	C2-236	C2-214	127 (58)	39 (989)	20 ¹ / ₂ (521)	17 (432)
	480	18.0	1	1	CFON721J11S	C/F	C/F	127 (58)	39 (989)	20 ¹ / ₂ (521)	17 (432)
	480	18.0	3	1	CFON721J5S	C2-43	C2-35	127 (58)	39 (989)	20 ¹ / ₂ (521)	17 (432)
	240	24.0	1	2	CFON727A10S	C/F	C/F	160 (73)	49 ¹ / ₂ (1256)	31 (787)	27 ¹ / ₂ (699)
	240	24.0	3	2	CFON727A3S	C2-218	C2-224	160 (73)	49 ¹ / ₂ (1256)	31 (787)	27 ¹ / ₂ (699)
	480	24.0	1	1	CFON727A11S	C/F	C/F	160 (73)	49 ¹ / ₂ (1256)	31 (787)	27 ¹ / ₂ (699)
	480	24.0	3	1	CFON727A5S	C2-225	C2-226	160 (73)	49 ¹ / ₂ (1256)	31 (787)	27 ¹ / ₂ (699)
	240	30.0	3	2	CFON732J3S	C2-218	C2-224	163 (74)	49 ¹ / ₂ (1256)	31 (787)	27 ¹ / ₂ (699)
	480	30.0	1	2	CFON732J11S	C/F	C/F	163 (74)	49 ¹ / ₂ (1256)	31 (787)	27 ¹ / ₂ (699)
	480	30.0	3	1	CFON732J5S	C2-225	C2-226	163 (74)	49 ¹ / ₂ (1256)	31 (787)	27 ¹ / ₂ (699)
	240	36.0	3	2	CFON738A3S	C2-218	C2-224	229 (104)	70 ¹ / ₂ (1789)	52 (1321)	48 ¹ / ₂ (1232)
	480	36.0	1	2	CFON738A11S	C/F	C/F	229 (104)	70 ¹ / ₂ (1789)	52 (1321)	48 ¹ / ₂ (1232)
	480	36.0	3	1	CFON738A5S	C2-225	C2-226	229 (104)	70 ¹ / ₂ (1789)	52 (1321)	48 ¹ / ₂ (1232)
	480	50.0	3	2	CFON751A5S	C2-229	C2-230	234 (107)	70 ¹ / ₂ (1789)	52 (1321)	48 ¹ / ₂ (1232)
	480	60.0	3	2	CFON760J5S	C2-229	C2-230	297 (135)	91 ¹ / ₂ (2326)	73 (1854)	66 (1676)

⑤ When steel vessel materials are used in this application, some rust may be present in the process media

C/F - Contact factory, go to www.watlow.com/en/contact-us

4 inch - 150 lb ANSI Flange

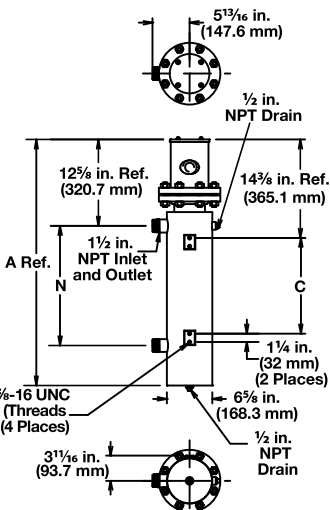

Circulation Heaters



WATROD and FIREBAR Circulation Heaters



Application: Clean Water®

- WATROD elements
- Without thermostat
- General purpose enclosure

Description	Volts	kW	Ph	Circ.	#	Part Number	WATCONNECT Part Number		Ship Wt. lbs (kg)	"A" Dim. in. (mm)	"N" Dim. in. (mm)	"C" Dim. in. (mm)
							Type J T/C	Type K T/C				
5 inch - 150 lb ANSI Flange (WATROD)												
60 W/in² Steel Tank 6-Alloy 800 Elements (9.3 W/cm²)	240	24.0	1	3		CFNN727A10S	C/F	C/F	140 (64)	49 ¹ / ₄ (1249.0)	30 (762)	14 ⁷ / ₈ (378.8)
	240	24.0	3	2		CFNN727A3S	C2-218	C2-224	140 (64)	49 ¹ / ₄ (1249.0)	30 (762)	14 ⁷ / ₈ (378.8)
	480	24.0	1	3		CFNN727A11S	C/F	C/F	140 (64)	49 ¹ / ₄ (1249.0)	30 (762)	14 ⁷ / ₈ (378.8)
	480	24.0	3	1		CFNN727A5S	C2-225	C2-226	140 (64)	49 ¹ / ₄ (1249.0)	30 (762)	14 ⁷ / ₈ (378.8)
	240	30.0	3	2		CFNN732J3S	C2-218	C2-224	142 (65)	49 ¹ / ₄ (1249.0)	30 (762)	14 ⁷ / ₈ (378.8)
	480	30.0	1	2		CFNN732J11S	C/F	C/F	142 (65)	49 ¹ / ₄ (1249.0)	30 (762)	14 ⁷ / ₈ (378.8)
	480	30.0	3	1		CFNN732J5S	C2-225	C2-226	142 (65)	49 ¹ / ₄ (1249.0)	30 (762)	14 ⁷ / ₈ (378.8)
	240	36.0	3	2		CFNN738A3S	C2-218	C2-224	160 (73)	56 ¹ / ₄ (1427.0)	37 (940)	18 ⁵ / ₈ (473.1)
	480	36.0	1	2		CFNN738A11S	C/F	C/F	160 (73)	56 ¹ / ₄ (1427.0)	37 (940)	18 ⁵ / ₈ (473.1)
	480	36.0	3	1		CFNN738A5S	C2-224	C2-226	160 (73)	56 ¹ / ₄ (1427.0)	37 (940)	18 ⁵ / ₈ (473.1)
	480	50.0	3	2		CFNN751A5S	C2-229	C2-230	180 (82)	67 ³ / ₄ (1719.0)	48 ¹ / ₂ (1232)	25 (633.0)
	480	60.0	3	2		CFNN760J5S	C2-229	C2-230	190 (87)	81 ¹ / ₈ (2060.6)	61 ⁷ / ₈ (1572)	30 ⁷ / ₈ (784.2)
5 inch - 150 lb ANSI Flange (WATROD)												
60 W/in² Steel Tank 9-Alloy 800 Elements (9.3 W/cm²)	240	36.0	3	3		CFNN727A3XS	C4-144	C4-145	145 (66)	49 ¹ / ₄ (1249.0)	30 (762)	14 ⁷ / ₈ (378.8)
	480	36.0	1	3		CFNN727A11XS	C/F	C/F	145 (66)	49 ¹ / ₄ (1249.0)	30 (762)	14 ⁷ / ₈ (378.8)
	480	36.0	3	1		CFNN727A5XS	C2-225	C2-226	145 (66)	49 ¹ / ₄ (1249.0)	30 (762)	14 ⁷ / ₈ (378.8)
	240	45.0	3	3		CFNN732J3XS	C4-144	C4-145	147 (67)	49 ¹ / ₄ (1249.0)	30 (762)	14 ⁷ / ₈ (378.8)
	480	45.0	1	3		CFNN732J11XS	C/F	C/F	147 (67)	49 ¹ / ₄ (1249.0)	30 (762)	14 ⁷ / ₈ (378.8)
	480	45.0	3	3		CFNN732J5XS	C4-150	C4-151	147 (67)	49 ¹ / ₄ (1249.0)	30 (762)	14 ⁷ / ₈ (378.8)
	240	54.0	3	3		CFNN738A3XS	C4-144	C4-145	166 (76)	56 ¹ / ₄ (1427.0)	37 (940)	18 ⁵ / ₈ (473.1)
	480	54.0	1	3		CFNN738A11XS	C/F	C/F	166 (76)	56 ¹ / ₄ (1427.0)	37 (940)	18 ⁵ / ₈ (473.1)
	480	54.0	3	3		CFNN738A5XS	C4-150	C4-151	166 (76)	56 ¹ / ₄ (1427.0)	37 (940)	18 ⁵ / ₈ (473.1)
	480	75.0	3	3		CFNN751A5XS	C4-152	C4-153	188 (86)	67 ³ / ₄ (1719.0)	48 ¹ / ₂ (1232)	25 (633.0)
	480	90.0	3	3		CFNN760J5XS	C4-152	C4-153	200 (91)	81 ¹ / ₈ (2060.6)	61 ⁷ / ₈ (1572)	30 ⁷ / ₈ (784.2)

⑤ When steel vessel materials are used in this application, some rust may be present in the process media

C/F - Contact factory, go to www.watlow.com/en/contact-us

5 inch - 150 lb ANSI Flange

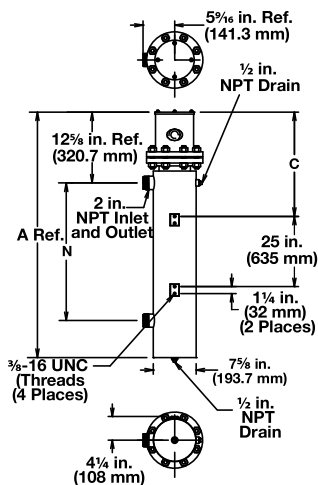

Circulation Heaters



WATROD and FIREBAR Circulation Heaters

Application: Deionized or Demineralized Water

- WATROD elements
- Without thermostat
- General purpose enclosure

Description	Volts	kW	Ph	Circ.	#	Part Number	WATCONNECT Part Number		Ship Wt. lbs (kg)	"A" Dim. in. (mm)	"N" Dim. in. (mm)	"C" Dim. in. (mm)
							Type J T/C	Type K T/C				
2 1/2 inch NPT Screw Plug (WATROD)												
60 W/in² 316 SS Tank 3-316 SS Elements (9.3 W/cm²) Passivated	240	6.0	3	1	1	CBLR714L3S	C2-50	C2-92	24 (11)	34 ³ / ₄ (881)	22 ¹ / ₂ (572)	16 ¹ / ₂ (419)
	480	6.0	3	1	1	CBLR714L5S	C2-43	C2-35	24 (11)	34 ³ / ₄ (881)	22 ¹ / ₂ (572)	16 ¹ / ₂ (419)
	240	7.5	3	1	1	CBLR717L3S	C2-50	C2-92	24 (11)	34 ³ / ₄ (881)	22 ¹ / ₂ (572)	16 ¹ / ₂ (419)
	480	7.5	3	1	1	CBLR717L5S	C2-43	C2-35	24 (11)	34 ³ / ₄ (881)	22 ¹ / ₂ (572)	16 ¹ / ₂ (419)
	240	9.0	3	1	1	CBLR720L3S	C2-50	C2-92	26 (12)	34 ³ / ₄ (881)	22 ¹ / ₂ (572)	16 ¹ / ₂ (419)
	480	9.0	3	1	1	CBLR720L5S	C2-43	C2-35	26 (12)	34 ³ / ₄ (881)	22 ¹ / ₂ (572)	16 ¹ / ₂ (419)
	240	12.0	3	1	1	CBLR726C3S	C2-236	C2-214	27 (13)	44 ³ / ₄ (1135)	32 ¹ / ₂ (826)	26 ¹ / ₂ (673)
	480	12.0	3	1	1	CBLR726C5S	C2-43	C2-35	27 (13)	44 ³ / ₄ (1135)	32 ¹ / ₂ (826)	26 ¹ / ₂ (673)
	240	15.0	3	1	1	CBLR731L3S	C2-236	C2-214	29 (14)	44 ³ / ₄ (1135)	32 ¹ / ₂ (826)	26 ¹ / ₂ (673)
	480	15.0	3	1	1	CBLR731L5S	C2-43	C2-35	29 (14)	44 ³ / ₄ (1135)	32 ¹ / ₂ (826)	26 ¹ / ₂ (673)
240	18.0	3	1	1	CBLR737C3S	C2-236	C2-214	30 (14)	57 ¹ / ₄ (1453)	45 (1143)	39 (991)	
480	18.0	3	1	1	CBLR737C5S	C2-43	C2-35	30 (14)	57 ¹ / ₄ (1453)	45 (1143)	39 (991)	
4 inch - 150 lb ANSI Flange (WATROD)												
60 W/in² 316 SS Tank 6-316 SS Elements (9.3 W/cm²) Passivated	240	12.0	1	2	1	CFOR716A10S	C/F	C/F	124 (57)	39 (989)	20 ¹ / ₂ (521)	17 (432)
	240	12.0	3	1	1	CFOR716A3S	C2-236	C2-214	124 (57)	39 (989)	20 ¹ / ₂ (521)	17 (432)
	480	12.0	1	1	1	CFOR716A11S	C/F	C/F	124 (57)	39 (989)	20 ¹ / ₂ (521)	17 (432)
	480	12.0	3	1	1	CFOR716A5S	C2-43	C2-35	124 (57)	39 (989)	20 ¹ / ₂ (521)	17 (432)
	240	18.0	1	2	1	CFOR722A10S	C/F	C/F	127 (58)	39 (989)	20 ¹ / ₂ (521)	17 (432)
	240	18.0	3	1	1	CFOR722A3S	C2-236	C2-214	127 (58)	39 (989)	20 ¹ / ₂ (521)	17 (432)
	480	18.0	1	1	1	CFOR722A11S	C/F	C/F	127 (58)	39 (989)	20 ¹ / ₂ (521)	17 (432)
	480	18.0	3	1	1	CFOR722A5S	C2-43	C2-35	127 (58)	39 (989)	20 ¹ / ₂ (521)	17 (432)
	240	24.0	1	2	1	CFOR727J10S	C/F	C/F	160 (73)	49 ¹ / ₂ (1256)	31 (787)	27 ¹ / ₂ (699)
	240	24.0	3	2	1	CFOR727J3S	C2-218	C2-224	160 (73)	49 ¹ / ₂ (1256)	31 (787)	27 ¹ / ₂ (699)
	480	24.0	1	1	1	CFOR727J11S	C/F	C/F	160 (73)	49 ¹ / ₂ (1256)	31 (787)	27 ¹ / ₂ (699)
	480	24.0	3	1	1	CFOR727J5S	C2-225	C2-226	160 (73)	49 ¹ / ₂ (1256)	31 (787)	27 ¹ / ₂ (699)
	240	30.0	3	2	1	CFOR733A3S	C2-218	C2-224	163 (74)	49 ¹ / ₂ (1256)	31 (787)	27 ¹ / ₂ (699)
	480	30.0	1	2	1	CFOR733A11S	C/F	C/F	163 (74)	49 ¹ / ₂ (1256)	31 (787)	27 ¹ / ₂ (699)
	480	30.0	3	1	1	CFOR733A5S	C2-225	C2-226	163 (74)	49 ¹ / ₂ (1256)	31 (787)	27 ¹ / ₂ (699)
	240	36.0	3	2	1	CFOR736J3S	C2-218	C2-226	229(104)	70 ¹ / ₂ (1789)	52 (1321)	48 ¹ / ₂ (1232)
	480	36.0	1	2	1	CFOR736J11S	C/F	C/F	229(104)	70 ¹ / ₂ (1789)	52 (1321)	48 ¹ / ₂ (1232)
	480	36.0	3	1	1	CFOR736J5S	C2-225	C2-226	229(104)	70 ¹ / ₂ (1789)	52 (1321)	48 ¹ / ₂ (1232)
	480	50.0	3	2	1	CFOR751J5S	C2-229	C2-230	234(107)	70 ¹ / ₂ (1789)	52 (1321)	48 ¹ / ₂ (1232)
	480	60.0	3	2	1	CFOR761A5S	C2-229	C2-230	297(135)	91 ¹ / ₂ (2326)	73 (1854)	66 (1676)

2 1/2 inch NPT Screw Plug

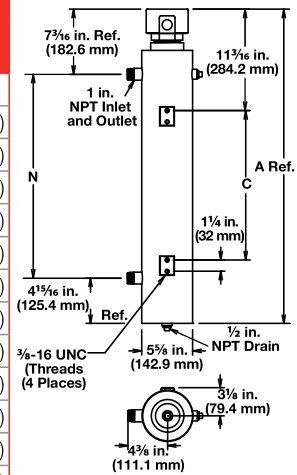

4 inch - 150 lb ANSI Flange

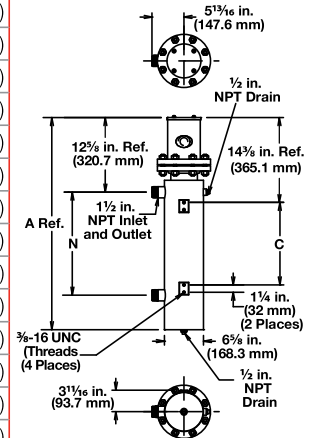

C/F - Contact factory, go to www.watlow.com/en/contact-us

Circulation Heaters



WATROD and FIREBAR Circulation Heaters



Application: Deionized or Demineralized Water

- WATROD elements
- Without thermostat
- General purpose enclosure

Description	Volts	kW	Ph	# Circ.	Part Number	WATCONNECT Part Number		Ship Wt. lbs (kg)	"A" Dim. in. (mm)	"N" Dim. in. (mm)	"C" Dim. in. (mm)	
						Type J T/C	Type K T/C					
6 inch - 150 lb ANSI Flange (WATROD)												
60 W/in² 316 SS Tank 12-316 SS Elements (9.3 W/cm²) Passivated	240	24.0	1	3	CFPR715N10S	C/F	C/F	212 (97)	40 ¹ / ₂ (1027)	20 ¹ / ₂ (521)	17 (432)	
	240	24.0	3	2	CFPR715N3S	C2-218	C2-224	212 (97)	40 ¹ / ₂ (1027)	20 ¹ / ₂ (521)	17 (432)	
	480	24.0	1	2	CFPR715N11S	C/F	C/F	212 (97)	40 ¹ / ₂ (1027)	20 ¹ / ₂ (521)	17 (432)	
	480	24.0	3	1	CFPR715N5S	C2-225	C2-226	212 (97)	40 ¹ / ₂ (1027)	20 ¹ / ₂ (521)	17 (432)	
	240	36.0	1	4	CFPR721N10S	C/F	C/F	217 (99)	40 ¹ / ₂ (1027)	20 ¹ / ₂ (521)	17 (432)	
	240	36.0	3	2	CFPR721N3S	C2-218	C2-224	217 (99)	40 ¹ / ₂ (1027)	20 ¹ / ₂ (521)	17 (432)	
	480	36.0	1	2	CFPR721N11S	C/F	C/F	217 (99)	40 ¹ / ₂ (1027)	20 ¹ / ₂ (521)	17 (432)	
	480	36.0	3	1	CFPR721N5S	C2-225	C2-226	217 (99)	40 ¹ / ₂ (1027)	20 ¹ / ₂ (521)	17 (432)	
	240	48.0	3	4	CFPR727E3S	C4-148	C4-149	222 (101)	51 (1294)	31 (787)	27 ¹ / ₂ (699)	
	480	48.0	1	3	CFPR727E11S	C/F	C/F	222 (101)	51 (1294)	31 (787)	27 ¹ / ₂ (699)	
	480	48.0	3	2	CFPR727E5S	C2-229	C2-230	222 (101)	51 (1294)	31 (787)	27 ¹ / ₂ (699)	
	240	60.0	3	4	CFPR732N3S	C4-148	C4-149	226 (103)	51 (1294)	31 (787)	27 ¹ / ₂ (699)	
	480	60.0	1	3	CFPR732N11S	C/F	C/F	226 (103)	51 (1294)	31 (787)	27 ¹ / ₂ (699)	
	480	60.0	3	2	CFPR732N5S	C2-229	C2-230	226 (103)	51 (1294)	31 (787)	27 ¹ / ₂ (699)	
	240	72.0	3	4	CFPR738E3S	C4-148	C4-149	290 (132)	72 (1827)	52 (1321)	48 ¹ / ₂ (1232)	
	480	72.0	3	2	CFPR738E5S	C2-229	C2-230	290 (132)	72 (1827)	52 (1321)	48 ¹ / ₂ (1232)	
480	100.0	3	4	CFPR751E5S	C4-156	C4-157	298 (136)	72 (1827)	52 (1321)	48 ¹ / ₂ (1232)		
480	120.0	3	4	CFPR760N5S	C4-156	C4-157	360 (164)	93 (2361)	73 (1854)	66 (1676)		

C/F - Contact factory, go to www.watlow.com/en/contact-us

6 inch - 150 lb ANSI Flange

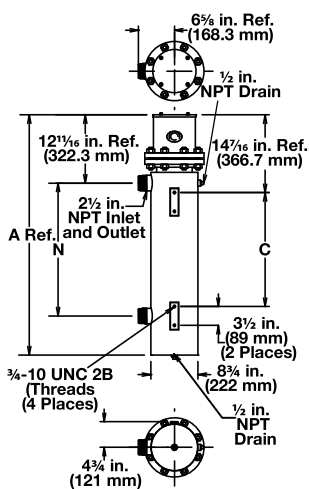



Circulation Heaters

WATROD and FIREBAR Circulation Heaters

Application: Deionized or Demineralized Water

- WATROD elements
- Without thermostat
- General purpose enclosure

Description	Volts	kW	Ph	# Circ.	Part Number	WATCONNECT Part Number		Ship Wt. lbs (kg)	"A" Dim. in. (mm)	"N" Dim. in. (mm)	"C" Dim. in. (mm)
						Type J T/C	Type K T/C				
6 inch - 150 lb ANSI Flange (WATROD)											
60 W/in² 316 SS Tank 15-316 SS Elements (9.3 W/cm²) Passivated	240	30.0	1	3	CFPR715N10XS	C/F	C/F	215 (98)	40 ¹ / ₂ (1027)	20 ¹ / ₂ (521)	17 (432)
	240	30.0	3	5	CFPR715N3XS	C4-144	C4-145	215 (98)	40 ¹ / ₂ (1027)	20 ¹ / ₂ (521)	17 (432)
	480	30.0	1	3	CFPR715N11XS	C/F	C/F	215 (98)	40 ¹ / ₂ (1027)	20 ¹ / ₂ (521)	17 (432)
	480	30.0	3	1	CFPR715N5XS	C2-225	C2-226	215 (98)	40 ¹ / ₂ (1027)	20 ¹ / ₂ (521)	17 (432)
	240	45.0	1	5	CFPR721N10XS	C/F	C/F	223 (102)	40 ¹ / ₂ (1027)	20 ¹ / ₂ (521)	17 (432)
	240	45.0	3	5	CFPR721N3XS	C4-144	C4-145	223 (102)	40 ¹ / ₂ (1027)	20 ¹ / ₂ (521)	17 (432)
	480	45.0	1	3	CFPR721N11XS	C/F	C/F	223 (102)	40 ¹ / ₂ (1027)	20 ¹ / ₂ (521)	17 (432)
	480	45.0	3	5	CFPR721N5XS	C4-150	C4-151	223 (102)	40 ¹ / ₂ (1027)	20 ¹ / ₂ (521)	17 (432)
	240	60.0	3	5	CFPR727E3XS	C/F	C/F	226 (103)	51 (1294)	31 (787)	27 ¹ / ₂ (699)
	480	60.0	1	3	CFPR727E11XS	C/F	C/F	226 (103)	51 (1294)	31 (787)	27 ¹ / ₂ (699)
	480	60.0	3	5	CFPR727E5XS	C4-152	C4-153	226 (103)	51 (1294)	31 (787)	27 ¹ / ₂ (699)
	240	75.0	3	5	CFPR732N3XS	C/F	C/F	288 (131)	51 (1294)	31 (787)	27 ¹ / ₂ (699)
	480	75.0	1	5	CFPR732N11XS	C/F	C/F	288 (131)	51 (1294)	31 (787)	27 ¹ / ₂ (699)
	480	75.0	3	5	CFPR732N5XS	C4-152	C4-153	288 (131)	51 (1294)	31 (787)	27 ¹ / ₂ (699)
	240	90.0	3	5	CFPR738E3XS	C/F	C/F	296 (135)	72 (1827)	52 (1321)	48 ¹ / ₂ (1232)
	480	90.0	3	5	CFPR738E5XS	C4-152	C4-153	296 (135)	72 (1827)	52 (1321)	48 ¹ / ₂ (1232)
	480	125.0	3	5	CFPR751E5XS	C/F	C/F	306 (139)	72 (1827)	52 (1321)	48 ¹ / ₂ (1232)
480	150.0	3	5	CFPR760N5XS	C/F	C/F	370 (168)	93 (2361)	73 (1854)	66 (1676)	

C/F - Contact factory, go to www.watlow.com/en/contact-us

6 inch - 150 lb ANSI Flange

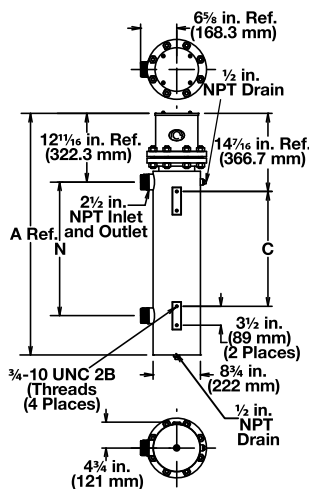



Circulation Heaters

WATROD and FIREBAR Circulation Heaters



Application: Process Water®

- WATROD or FIREBAR elements
- Without thermostat
- General purpose enclosure

Description	Volts	kW	Ph	Circ.	#	Part Number	WATCONNECT Part Number		Ship Wt. lbs (kg)	"A" Dim. in. (mm)	"N" Dim. in. (mm)	"C" Dim. in. (mm)
							Type J T/C	Type K T/C				
1 1/4 inch NPT Screw Plug (FIREBAR)												
45 W/in ² Ⓢ Steel Tank 1-Alloy 800 Element (7 W/cm ²)	240	2.0	3	1		CBDNF13A27S	C2-50	C2-92	25 (12)	24 ⁵ / ₈ (625.5)	15 (381)	3 1/8 (79.4)
	240	2.5	3	1		CBDNF15J27S	C2-50	C2-92	26 (12)	24 ⁵ / ₈ (625.5)	15 (381)	3 1/8 (79.4)
	240	3.0	3	1		CBDNF18A27S	C2-50	C2-92	30 (14)	32 ⁵ / ₈ (828.7)	23 (584)	3 1/8 (79.4)
	240	4.0	3	1		CBDNF22J27S	C2-50	C2-92	31 (14)	32 ⁵ / ₈ (828.7)	23 (584)	3 1/8 (79.4)
	480	4.0	3	1		CBDNF22J28S	C2-43	C2-35	31 (14)	32 ⁵ / ₈ (828.7)	23 (584)	3 1/8 (79.4)
	240	5.0	3	1		CBDNF27J27S	C2-50	C2-92	43 (20)	42 ⁵ / ₈ (1082.7)	32 (813)	4 3/8 (111.1)
	480	5.0	3	1		CBDNF27J28S	C2-43	C2-35	43 (20)	42 ⁵ / ₈ (1082.7)	32 (813)	4 3/8 (111.1)
	240	6.0	3	1		CBDNF32J27S	C2-50	C2-92	44 (20)	42 ⁵ / ₈ (1082.7)	32 (813)	4 3/8 (111.1)
	480	6.0	3	1		CBDNF32J28S	C2-43	C2-35	44 (20)	42 ⁵ / ₈ (1082.7)	32 (813)	4 3/8 (111.1)
	240	8.0	3	1		CBDNF42A27S	C2-50	C2-92	69 (32)	63 ⁵ / ₈ (1616.1)	53 (1346)	4 3/8 (111.1)
	480	8.0	3	1		CBDNF42A28S	C2-43	C2-35	69 (32)	63 ⁵ / ₈ (1616.1)	53 (1346)	4 3/8 (111.1)
	240	10.0	3	1		CBDNF51J27S	C2-50	C2-92	71 (33)	63 ⁵ / ₈ (1616.1)	53 (1346)	4 3/8 (111.1)
480	10.0	3	1		CBDNF51J28S	C2-43	C2-35	71 (33)	63 ⁵ / ₈ (1616.1)	53 (1346)	4 3/8 (111.1)	
2 1/2 inch NPT Screw Plug (WATROD)												
48 W/in ² Ⓢ Steel Tank 3-Alloy 800 Elements (7.5 W/cm ²)	240	6.0	3	1		CBLN717G3S	C2-50	C2-92	24 (11)	34 ³ / ₄ (881)	22 1/2 (572)	16 1/2 (419)
	480	6.0	3	1		CBLN717G5S	C2-43	C2-35	24 (11)	34 ³ / ₄ (881)	22 1/2 (572)	16 1/2 (419)
	240	7.5	3	1		CBLN719R3S	C2-50	C2-92	26 (12)	34 ³ / ₄ (881)	22 1/2 (572)	16 1/2 (419)
	480	7.5	3	1		CBLN719R5S	C2-43	C2-35	26 (12)	34 ³ / ₄ (881)	22 1/2 (572)	16 1/2 (419)
	240	9.0	3	1		CBLN724R3S	C2-50	C2-92	27 (13)	34 ³ / ₄ (881)	22 1/2 (572)	16 1/2 (419)
	480	9.0	3	1		CBLN724R5S	C2-43	C2-35	27 (13)	34 ³ / ₄ (881)	22 1/2 (572)	16 1/2 (419)
	240	12.0	3	1		CBLN732G3S	C2-236	C2-214	29 (14)	44 ³ / ₄ (1135)	32 1/2 (826)	26 1/2 (673)
	480	12.0	3	1		CBLN732G5S	C2-43	C2-35	29 (14)	44 ³ / ₄ (1135)	32 1/2 (826)	26 1/2 (673)
	240	15.0	3	1		CBLN739R3S	C2-236	C2-214	31 (14)	57 1/4 (1453)	45 (1143)	39 (991)
	480	15.0	3	1		CBLN739R5S	C2-43	C2-35	31 (14)	57 1/4 (1453)	45 (1143)	39 (991)
	240	18.0	3	1		CBLN747G3S	C2-236	C2-214	32 (15)	57 1/4 (1453)	45 (1143)	39 (991)
	480	18.0	3	1		CBLN747G5S	C2-43	C2-35	32 (15)	57 1/4 (1453)	45 (1143)	39 (991)
2 1/2 inch NPT Screw Plug (FIREBAR)												
45 W/in ² Ⓢ Steel Tank 3-Alloy 800 Elements (7 W/cm ²)	240	6.0	3	1		CBLNF12A27S	C2-50	C2-92	21 (10)	34 ³ / ₄ (881)	22 1/2 (572)	16 1/2 (419)
	240	7.5	3	1		CBLNF14J27S	C2-50	C2-92	22 (10)	34 ³ / ₄ (881)	22 1/2 (572)	16 1/2 (419)
	240	9.0	3	1		CBLNF17A27S	C2-50	C2-92	23 (11)	34 ³ / ₄ (881)	22 1/2 (572)	16 1/2 (419)
	240	12.0	3	1		CBLNF21J27S	C2-236	C2-214	31 (14)	34 ³ / ₄ (881)	22 1/2 (572)	16 1/2 (419)
	480	12.0	3	1		CBLNF21J28S	C2-43	C2-35	31 (14)	34 ³ / ₄ (881)	22 1/2 (572)	16 1/2 (419)
	240	15.0	3	1		CBLNF26J27S	C2-236	C2-214	34 (16)	44 ³ / ₄ (1135)	32 1/2 (826)	26 1/2 (673)
	480	15.0	3	1		CBLNF26J28S	C2-43	C2-35	34 (16)	44 ³ / ₄ (1135)	32 1/2 (826)	26 1/2 (673)
	240	18.0	3	1		CBLNF31J27S	C2-236	C2-214	35 (16)	44 ³ / ₄ (1135)	32 1/2 (826)	26 1/2 (673)
	480	18.0	3	1		CBLNF31J28S	C2-43	C2-35	35 (16)	44 ³ / ₄ (1135)	32 1/2 (826)	26 1/2 (673)
	480	24.0	3	1		CBLNF41A28S	C2-225	C2-226	44 (20)	57 1/4 (1453)	45 (1143)	39 (991)
	480	30.0	3	1		CBLNF50J28S	C2-225	C2-226	52 (24)	63 ³ / ₄ (1618)	51 1/2 (1308)	46 1/2 (1181)

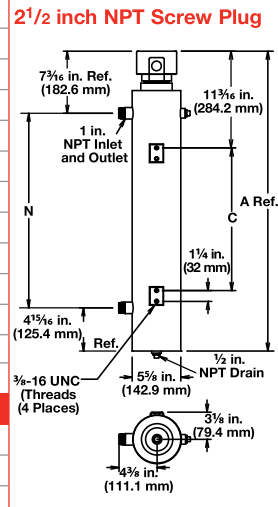
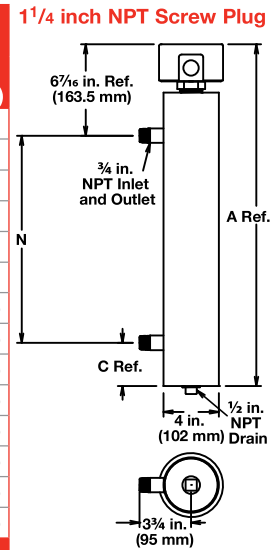

Ⓢ When steel vessel materials are used in this application, some rust may be present in the process media
 Ⓢ Can be wired for 1-phase operation

Circulation Heaters



WATROD and FIREBAR Circulation Heaters



Application: Process Water[®]

- WATROD elements
- Without thermostat
- General purpose enclosure

Description	Volts	kW	Ph	# Circ.	Part Number	WATCONNECT Part Number		Ship Wt. lbs (kg)	"A" Dim. in. (mm)	"N" Dim. in. (mm)	"C" Dim. in. (mm)
						Type J T/C	Type K T/C				
3 inch - 150 lb ANSI Flange (WATROD)											
48 W/in² Steel Tank 3-Alloy 800 Elements (7.5 W/cm²)	240	6.0	1	1	CFMN718A10S	C/F	C/F	68 (31)	35 ¹ / ₄ (894)	22 ¹ / ₂ (573)	16 ¹ / ₂ (419)
	240	6.0	3	1	CFMN718A3S	C2-50	C2-92	68 (31)	35 ¹ / ₄ (894)	22 ¹ / ₂ (573)	16 ¹ / ₂ (419)
	480	6.0	1	1	CFMN718A11S	C/F	C/F	68 (31)	35 ¹ / ₄ (894)	22 ¹ / ₂ (573)	16 ¹ / ₂ (419)
	480	6.0	3	1	CFMN718A5S	C2-43	C2-35	68 (31)	35 ¹ / ₄ (894)	22 ¹ / ₂ (573)	16 ¹ / ₂ (419)
	240	7.5	1	1	CFMN720J10S	C/F	C/F	70 (32)	35 ¹ / ₄ (894)	22 ¹ / ₂ (573)	16 ¹ / ₂ (419)
	240	7.5	3	1	CFMN720J3S	C2-50	C2-92	70 (32)	35 ¹ / ₄ (894)	22 ¹ / ₂ (573)	16 ¹ / ₂ (419)
	480	7.5	1	1	CFMN720J11S	C/F	C/F	70 (32)	35 ¹ / ₄ (894)	22 ¹ / ₂ (573)	16 ¹ / ₂ (419)
	480	7.5	3	1	CFMN720J5S	C2-43	C2-35	70 (32)	35 ¹ / ₄ (894)	22 ¹ / ₂ (573)	16 ¹ / ₂ (419)
	240	9.0	1	1	CFMN725J10S	C/F	C/F	78 (36)	45 ¹ / ₄ (1148)	32 ¹ / ₂ (826)	26 ¹ / ₂ (673)
	240	9.0	3	1	CFMN725J3S	C2-50	C2-92	78 (36)	45 ¹ / ₄ (1148)	32 ¹ / ₂ (826)	26 ¹ / ₂ (673)
	480	9.0	1	1	CFMN725J11S	C/F	C/F	78 (36)	45 ¹ / ₄ (1148)	32 ¹ / ₂ (826)	26 ¹ / ₂ (673)
	480	9.0	3	1	CFMN725J5S	C2-43	C2-35	78 (36)	45 ¹ / ₄ (1148)	32 ¹ / ₂ (826)	26 ¹ / ₂ (673)
	240	12.0	3	1	CFMN733A3S	C2-236	C2-214	96 (44)	45 ¹ / ₄ (1148)	32 ¹ / ₂ (826)	26 ¹ / ₂ (673)
	480	12.0	1	1	CFMN733A11S	C/F	C/F	96 (44)	45 ¹ / ₄ (1148)	32 ¹ / ₂ (826)	26 ¹ / ₂ (673)
	480	12.0	3	1	CFMN733A5S	C2-43	C2-35	96 (44)	45 ¹ / ₄ (1148)	32 ¹ / ₂ (826)	26 ¹ / ₂ (673)
	240	15.0	3	1	CFMN740J3S	C2-236	C2-214	100 (46)	57 ³ / ₄ (1465)	45 (1143)	39 (991)
	480	15.0	1	1	CFMN740J11S	C/F	C/F	100 (46)	57 ³ / ₄ (1465)	45 (1143)	39 (991)
	480	15.0	3	1	CFMN740J5S	C2-43	C2-35	100 (46)	57 ³ / ₄ (1465)	45 (1143)	39 (991)
	240	18.0	3	1	CFMN748A3S	C2-236	C2-214	107 (49)	57 ³ / ₄ (1465)	45 (1143)	39 (991)
	480	18.0	1	1	CFMN748A11S	C/F	C/F	107 (49)	57 ³ / ₄ (1465)	45 (1143)	39 (991)
480	18.0	3	1	CFMN748A5S	C2-43	C2-35	107 (49)	57 ³ / ₄ (1465)	45 (1143)	39 (991)	

⑤ When steel vessel materials are used in this application, some rust may be present in the process media
 C/F - Contact factory, go to www.watlow.com/en/contact-us

3 inch - 150 lb ANSI Flange

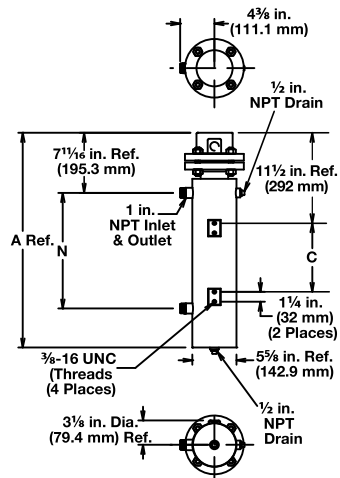

Circulation Heaters



WATROD and FIREBAR Circulation Heaters



Application: Process Water[®]

- WATROD elements
- Without thermostat
- General purpose enclosure

Description	Volts	kW	Ph	# Circ.	Part Number	WATCONNECT Part Number		Ship Wt. lbs (kg)	"A" Dim. in. (mm)	"N" Dim. in. (mm)	"C" Dim. in. (mm)
						Type J T/C	Type K T/C				
4 inch - 150 lb ANSI Flange (WATROD)											
48 W/in² Steel Tank 6-Alloy 800 Elements (7.5 W/cm²)	240	9.0	1	1	CFON713J10S	C/F	C/F	122 (56)	39 (989)	20 ¹ / ₂ (521)	17 (432)
	240	9.0	3	1	CFON713J3S	C2-50	C2-92	122 (56)	39 (989)	20 ¹ / ₂ (521)	17 (432)
	480	9.0	1	1	CFON713J11S	C/F	C/F	122 (56)	39 (989)	20 ¹ / ₂ (521)	17 (432)
	480	9.0	3	1	CFON713J5S	C2-43	C2-35	122 (56)	39 (989)	20 ¹ / ₂ (521)	17 (432)
	240	12.0	1	2	CFON718A10S	C/F	C/F	125 (57)	39 (989)	20 ¹ / ₂ (521)	17 (432)
	240	12.0	3	1	CFON718A3S	C2-236	C2-214	125 (57)	39 (989)	20 ¹ / ₂ (521)	17 (432)
	480	12.0	1	1	CFON718A11S	C/F	C/F	125 (57)	39 (989)	20 ¹ / ₂ (521)	17 (432)
	480	12.0	3	1	CFON718A5S	C2-43	C2-35	125 (57)	39 (989)	20 ¹ / ₂ (521)	17 (432)
	240	15.0	1	2	CFON720J10S	C/F	C/F	127 (58)	39 (989)	20 ¹ / ₂ (521)	17 (432)
	240	15.0	3	1	CFON720J3S	C2-236	C2-214	127 (58)	39 (989)	20 ¹ / ₂ (521)	17 (432)
	480	15.0	1	1	CFON720J11S	C/F	C/F	127 (58)	39 (989)	20 ¹ / ₂ (521)	17 (432)
	480	15.0	3	1	CFON720J5S	C2-225	C2-226	127 (58)	39 (989)	20 ¹ / ₂ (521)	17 (432)
	240	18.0	1	2	CFON725J10S	C/F	C/F	160 (73)	39 (989)	20 ¹ / ₂ (521)	17 (432)
	240	18.0	3	1	CFON725J3S	C2-236	C2-214	160 (73)	39 (989)	20 ¹ / ₂ (521)	17 (432)
	480	18.0	1	1	CFON725J11S	C/F	C/F	160 (73)	39 (989)	20 ¹ / ₂ (521)	17 (432)
	480	18.0	3	1	CFON725J5S	C2-43	C2-35	160 (73)	39 (989)	20 ¹ / ₂ (521)	17 (432)
	240	24.0	1	2	CFON733A10S	C/F	C/F	163 (74)	49 ¹ / ₂ (1256)	31 (787)	27 ¹ / ₂ (699)
	240	24.0	3	2	CFON733A3S	C2-218	C2-224	163 (74)	49 ¹ / ₂ (1256)	31 (787)	27 ¹ / ₂ (699)
	480	24.0	1	1	CFON733A11S	C/F	C/F	163 (74)	49 ¹ / ₂ (1256)	31 (787)	27 ¹ / ₂ (699)
	480	24.0	3	1	CFON733A5S	C2-225	C2-226	163 (74)	49 ¹ / ₂ (1256)	31 (787)	27 ¹ / ₂ (699)
240	30.0	3	2	CFON740J3S	C2-218	C2-224	229 (104)	70 ¹ / ₂ (1789)	52 (1321)	48 ¹ / ₂ (1232)	
480	30.0	1	2	CFON740J11S	C/F	C/F	229 (104)	70 ¹ / ₂ (1789)	52 (1321)	48 ¹ / ₂ (1232)	
480	30.0	3	1	CFON740J5S	C2-225	C2-226	229 (104)	70 ¹ / ₂ (1789)	52 (1321)	48 ¹ / ₂ (1232)	
240	36.0	3	2	CFON748A3S	C2-218	C2-224	234 (107)	70 ¹ / ₂ (1789)	52 (1321)	48 ¹ / ₂ (1232)	
480	36.0	1	2	CFON748A11S	C/F	C/F	234 (107)	70 ¹ / ₂ (1789)	52 (1321)	48 ¹ / ₂ (1232)	
480	36.0	3	1	CFON748A5S	C2-225	C2-226	234 (107)	70 ¹ / ₂ (1789)	52 (1321)	48 ¹ / ₂ (1232)	

⑤ When steel vessel materials are used in this application, some rust may be present in the process media

C/F - Contact factory, go to www.watlow.com/en/contact-us

4 inch - 150 lb ANSI Flange

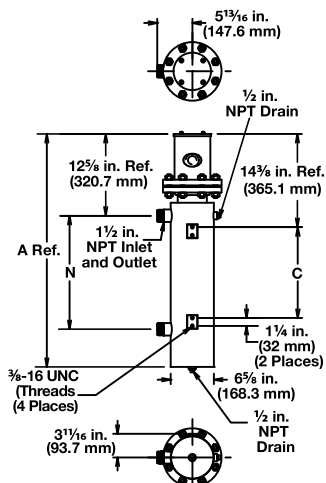

Circulation Heaters



WATROD and FIREBAR Circulation Heaters



Application: Process Water®

- WATROD elements
- Without thermostat
- General purpose enclosure

Description	Volts	kW	Ph	# Circ.	Part Number	WATCONNECT Part Number		Ship Wt. lbs (kg)	"A" Dim. in. (mm)		"N" Dim. in. (mm)		"C" Dim. in. (mm)	
						Type J T/C	Type K T/C							
5 inch - 150 lb ANSI Flange (WATROD)														
48 W/in ² Steel Tank 6-Alloy 800 Elements (7.5 W/cm ²)	240	24.0	1	3	CFNN733A10S	C/F	C/F	145 (66)	49 ¹ / ₄ (1249)	30 (762)	14 ⁷ / ₈ (377.8)			
	240	24.0	3	2	CFNN733A3S	C2-218	C2-224	145 (66)	49 ¹ / ₄ (1249)	30 (762)	14 ⁷ / ₈ (377.8)			
	480	24.0	1	2	CFNN733A11S	C/F	C/F	145 (66)	49 ¹ / ₄ (1249)	30 (762)	14 ⁷ / ₈ (377.8)			
	480	24.0	3	1	CFNN733A5S	C2-225	C2-226	145 (66)	49 ¹ / ₄ (1249)	30 (762)	14 ⁷ / ₈ (377.8)			
	240	30.0	3	2	CFNN740J3S	C2-218	C2-224	167 (76)	56 ¹ / ₄ (1427)	37 (940)	18 ⁵ / ₈ (473.1)			
	480	30.0	1	2	CFNN740J11S	C/F	C/F	167 (76)	56 ¹ / ₄ (1427)	37 (940)	18 ⁵ / ₈ (473.1)			
	480	30.0	3	1	CFNN740J5S	C2-225	C2-226	167 (76)	56 ¹ / ₄ (1427)	37 (940)	18 ⁵ / ₈ (473.1)			
	240	36.0	3	2	CFNN748A3S	C2-218	C2-224	180 (82)	67 ³ / ₄ (1719)	48 ¹ / ₂ (1232)	25 (633.0)			
	480	36.0	1	2	CFNN748A11S	C/F	C/F	180 (82)	67 ³ / ₄ (1719)	48 ¹ / ₂ (1232)	25 (633.0)			
480	36.0	3	1	CFNN748A5S	C2-225	C2-226	180 (82)	67 ³ / ₄ (1719)	48 ¹ / ₂ (1232)	25 (633.0)				
5 inch - 150 lb ANSI Flange (WATROD)														
48 W/in ² Steel Tank 9-Alloy 800 Elements (7.5 W/cm ²)	240	36.0	3	3	CFNN733A3XS	C4-144	C4-145	150 (68)	49 ¹ / ₄ (1249)	30 (762)	14 ⁷ / ₈ (377.8)			
	480	36.0	1	3	CFNN733A11XS	C/F	C/F	150 (68)	49 ¹ / ₄ (1249)	30 (762)	14 ⁷ / ₈ (377.8)			
	480	36.0	3	1	CFNN733A5XS	C2-225	C2-226	150 (68)	49 ¹ / ₄ (1249)	30 (762)	14 ⁷ / ₈ (377.8)			
	240	45.0	3	3	CFNN740J3XS	C4-144	C4-145	173 (79)	56 ¹ / ₄ (1427)	37 (940)	18 ⁵ / ₈ (473.1)			
	480	45.0	1	3	CFNN740J11XS	C/F	C/F	173 (79)	56 ¹ / ₄ (1427)	37 (940)	18 ⁵ / ₈ (473.1)			
	480	45.0	3	3	CFNN740J5XS	C4-150	C4-151	173 (79)	56 ¹ / ₄ (1427)	37 (940)	18 ⁵ / ₈ (473.1)			
	240	54.0	3	3	CFNN748A3XS	C4-144	C4-145	188 (86)	67 ³ / ₄ (1719)	48 ¹ / ₂ (1232)	25 (633.0)			
	480	54.0	1	3	CFNN748A11XS	C/F	C/F	188 (86)	67 ³ / ₄ (1719)	48 ¹ / ₂ (1232)	25 (633.0)			
	480	54.0	3	3	CFNN748A5XS	C4-150	C4-151	188 (86)	67 ³ / ₄ (1719)	48 ¹ / ₂ (1232)	25 (633.0)			

⑤ When steel vessel materials are used in this application, some rust may be present in the process media
 C/F - Contact factory, go to www.watlow.com/en/contact-us

5 inch - 150 lb ANSI Flange

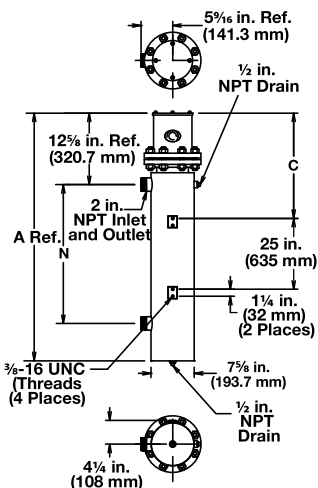



Circulation Heaters

WATROD and FIREBAR Circulation Heaters

Application: Process Water[®]

- WATROD elements
- Without thermostat
- General purpose enclosure

Description	Volts	kW	Ph	# Circ.	Part Number	WATCONNECT Part Number		Ship Wt. lbs (kg)	"A" Dim. in. (mm)	"N" Dim. in. (mm)	"C" Dim. in. (mm)
						Type J T/C	Type K T/C				
6 inch - 150 lb ANSI Flange (WATROD)											
48 W/in ² Steel Tank 12-Alloy 800 Elements (7.5 W/cm ²)	240	18.0	1	2	CFPN713G10S	C/F	C/F	212 (97)	40 1/2 (1027)	20 1/2 (521)	17 (432)
	240	18.0	3	1	CFPN713G3S	C2-236	C2-214	212 (97)	40 1/2 (1027)	20 1/2 (521)	17 (432)
	480	18.0	1	1	CFPN713G11S	C/F	C/F	212 (97)	40 1/2 (1027)	20 1/2 (521)	17 (432)
	480	18.0	3	1	CFPN713G5S	C2-43	C2-35	212 (97)	40 1/2 (1027)	20 1/2 (521)	17 (432)
	240	24.0	1	3	CFPN717R10S	C/F	C/F	214 (97)	40 1/2 (1027)	20 1/2 (521)	17 (432)
	240	24.0	3	2	CFPN717R3S	C2-218	C2-224	214 (97)	40 1/2 (1027)	20 1/2 (521)	17 (432)
	480	24.0	1	2	CFPN717R11S	C/F	C/F	214 (97)	40 1/2 (1027)	20 1/2 (521)	17 (432)
	480	24.0	3	1	CFPN717R5S	C2-225	C2-226	214 (97)	40 1/2 (1027)	20 1/2 (521)	17 (432)
	240	30.0	1	3	CFPN720G10S	C/F	C/F	217 (99)	40 1/2 (1027)	20 1/2 (521)	17 (432)
	240	30.0	3	2	CFPN720G3S	C2-218	C2-224	217 (99)	40 1/2 (1027)	20 1/2 (521)	17 (432)
	480	30.0	1	2	CFPN720G11S	C/F	C/F	217 (99)	40 1/2 (1027)	20 1/2 (521)	17 (432)
	480	30.0	3	1	CFPN720G5S	C2-225	C2-226	217 (99)	40 1/2 (1027)	20 1/2 (521)	17 (432)
	240	36.0	1	4	CFPN725G10S	C/F	C/F	222 (101)	40 1/2 (1027)	20 1/2 (521)	17 (432)
	240	36.0	3	2	CFPN725G3S	C2-218	C2-224	222 (101)	40 1/2 (1027)	20 1/2 (521)	17 (432)
	480	36.0	1	2	CFPN725G11S	C/F	C/F	222 (101)	40 1/2 (1027)	20 1/2 (521)	17 (432)
	480	36.0	3	1	CFPN725G5S	C2-225	C2-226	222 (101)	40 1/2 (1027)	20 1/2 (521)	17 (432)
	240	48.0	3	4	CFPN732R3S	C4-148	C4-149	226 (103)	51 (1294)	31 (787)	27 1/2 (699)
	480	48.0	1	3	CFPN732R11S	C/F	C/F	226 (103)	51 (1294)	31 (787)	27 1/2 (699)
	480	48.0	3	2	CFPN732R5S	C2-229	C2-230	226 (103)	51 (1294)	31 (787)	27 1/2 (699)
	240	60.0	3	4	CFPN740G3S	C4-148	C4-149	290 (132)	72 (1827)	52 (1321)	48 1/2 (1232)
	480	60.0	1	3	CFPN740G11S	C/F	C/F	290 (132)	72 (1827)	52 (1321)	48 1/2 (1232)
	480	60.0	3	2	CFPN740G5S	C2-229	C2-230	290 (132)	72 (1827)	52 (1321)	48 1/2 (1232)
	240	72.0	3	4	CFPN747R3S	C4-148	C4-149	298 (136)	72 (1827)	52 (1321)	48 1/2 (1232)
	480	72.0	3	2	CFPN747R5S	C2-229	C2-230	298 (136)	72 (1827)	52 (1321)	48 1/2 (1232)
6 inch - 150 lb ANSI Flange (WATROD)											
48 W/in ² Steel Tank 15-Alloy 800 Elements (7.5 W/cm ²)	240	23.0	1	3	CFPN713G10XS	C/F	C/F	215 (98)	40 1/2 (1027)	20 1/2 (521)	17 (432)
	240	23.0	3	5	CFPN713G3XS	C4-143	C4-142	215 (98)	40 1/2 (1027)	20 1/2 (521)	17 (432)
	480	23.0	1	1	CFPN713G11XS	C/F	C/F	215 (98)	40 1/2 (1027)	20 1/2 (521)	17 (432)
	480	23.0	3	1	CFPN713G5XS	C2-225	C2-226	215 (98)	40 1/2 (1027)	20 1/2 (521)	17 (432)
	240	30.0	1	3	CFPN717R10XS	C/F	C/F	217 (99)	40 1/2 (1027)	20 1/2 (521)	17 (432)
	240	30.0	3	5	CFPN717R3XS	C4-144	C4-145	217 (99)	40 1/2 (1027)	20 1/2 (521)	17 (432)
	480	30.0	1	3	CFPN717R11XS	C/F	C/F	217 (99)	40 1/2 (1027)	20 1/2 (521)	17 (432)
	480	30.0	3	1	CFPN717R5XS	C2-225	C2-226	217 (99)	40 1/2 (1027)	20 1/2 (521)	17 (432)
	240	38.0	1	5	CFPN720G10XS	C/F	C/F	223 (102)	40 1/2 (1027)	20 1/2 (521)	17 (432)
	240	38.0	3	5	CFPN720G3XS	C4-144	C4-145	223 (102)	40 1/2 (1027)	20 1/2 (521)	17 (432)
	480	38.0	1	3	CFPN720G11XS	C/F	C/F	223 (102)	40 1/2 (1027)	20 1/2 (521)	17 (432)
	480	38.0	3	1	CFPN720G5XS	C2-225	C2-226	223 (102)	40 1/2 (1027)	20 1/2 (521)	17 (432)
	240	45.0	1	5	CFPN725G10XS	C/F	C/F	226 (103)	40 1/2 (1027)	20 1/2 (521)	17 (432)
	240	45.0	3	5	CFPN725G3XS	C4-144	C4-145	226 (103)	40 1/2 (1027)	20 1/2 (521)	17 (432)
	480	45.0	1	3	CFPN725G11XS	C/F	C/F	226 (103)	40 1/2 (1027)	20 1/2 (521)	17 (432)
	480	45.0	3	5	CFPN725G5XS	C4-150	C4-151	226 (103)	40 1/2 (1027)	20 1/2 (521)	17 (432)
	240	60.0	3	5	CFPN732R3XS	C/F	C/F	288 (131)	51 (1294)	31 (787)	27 1/2 (699)
	480	60.0	1	3	CFPN732R11XS	C/F	C/F	288 (131)	51 (1294)	31 (787)	27 1/2 (699)
	480	60.0	3	5	CFPN732R5XS	C4-152	C4-153	288 (131)	51 (1294)	31 (787)	27 1/2 (699)
	240	75.0	3	5	CFPN740G3XS	C/F	C/F	296 (135)	72 (1827)	52 (1321)	48 1/2 (1232)
	480	75.0	1	5	CFPN740G11XS	C/F	C/F	296 (135)	72 (1827)	52 (1321)	48 1/2 (1232)
	480	75.0	3	5	CFPN740G5XS	C4-152	C4-153	296 (135)	72 (1827)	52 (1321)	48 1/2 (1232)
	240	90.0	3	5	CFPN747R3XS	C/F	C/F	306 (139)	72 (1827)	52 (1321)	48 1/2 (1232)
	480	90.0	3	5	CFPN747R5XS	C4-152	C4-153	306 (139)	72 (1827)	52 (1321)	48 1/2 (1232)

6 inch - 150 lb ANSI Flange

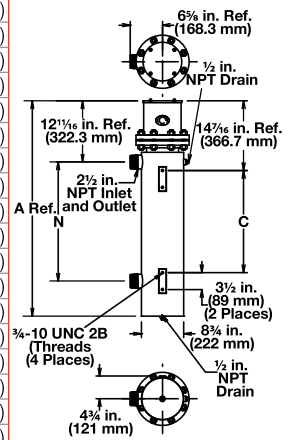

® When steel vessel materials are used in this application, some rust may be present in the process media
C/F - Contact factory, go to www.watlow.com/en/contact-us

Circulation Heaters



WATROD and FIREBAR Circulation Heaters

Application: Process Water®

- WATROD elements
- Without thermostat
- General purpose enclosure

Description	Volts	kW	# Ph	Circ.	Part Number	WATCONNECT Part Number		Ship Wt. lbs (kg)	"A" Dim. in. (mm)	"N" Dim. in. (mm)	"C" Dim. in. (mm)
						Type J T/C	Type K T/C				
8 inch - 150 lb ANSI Flange (WATROD)											
48 W/in ² Steel Tank 18-Alloy 800 Elements (7.5 W/cm ²)	240	50.0	3	3	CFRN725N3S	C4-144	C4-145	350 (159)	55 ¹ / ₄ (1402.0)	32 ³ / ₄ (830.0)	29 ¹ / ₄ (741.0)
	480	50.0	1	3	CFRN725N11S	C/F	C/F	350 (159)	55 ¹ / ₄ (1402.0)	32 ³ / ₄ (830.0)	29 ¹ / ₄ (741.0)
	480	50.0	3	2	CFRN725N5S	C2-229	C2-230	350 (159)	55 ¹ / ₄ (1402.0)	32 ³ / ₄ (830.0)	29 ¹ / ₄ (741.0)
	240	75.0	3	6	CFRN735N3S	C/F	C/F	380 (173)	62 ¹ / ₄ (1580.0)	39 ³ / ₄ (1008.0)	36 ¹ / ₄ (919.0)
	480	75.0	3	2	CFRN735N5S	C2-229	C2-230	380 (173)	62 ¹ / ₄ (1580.0)	39 ³ / ₄ (1008.0)	36 ¹ / ₄ (919.0)
	240	100.0	3	6	CFRN744E3S	C/F	C/F	410 (186)	69 ⁷ / ₈ (1774.8)	47 ³ / ₈ (1203.3)	43 ⁷ / ₈ (1114.4)
	480	100.0	3	3	CFRN744E5S	C2-229	C2-230	410 (186)	69 ⁷ / ₈ (1774.8)	47 ³ / ₈ (1203.3)	43 ⁷ / ₈ (1114.4)
	240	125.0	3	6	CFRN754M3S	C/F	C/F	445 (202)	79 ³ / ₈ (2016.1)	56 ⁷ / ₈ (1444.6)	53 ³ / ₈ (1355.7)
	480	125.0	3	6	CFRN754M5S	C/F	C/F	445 (202)	79 ³ / ₈ (2016.1)	56 ⁷ / ₈ (1444.6)	53 ³ / ₈ (1355.7)
	480	150.0	3	6	CFRN763M5S	C/F	C/F	490 (223)	88 ³ / ₈ (2244.7)	65 ⁷ / ₈ (1673.2)	62 ³ / ₈ (1584.3)
	480	175.0	3	6	CFRN773D5S	C/F	C/F	530 (241)	98 ³ / ₈ (2498.7)	75 ⁷ / ₈ (1927.2)	72 ³ / ₈ (1838.3)
480	200.0	3	6	CFRN782M5S	C/F	C/F	560 (254)	98 ³ / ₈ (2498.7)	75 ⁷ / ₈ (1927.2)	72 ³ / ₈ (1838.3)	
8 inch - 150 lb ANSI Flange (WATROD)											
48 W/in ² Steel Tank 24-Alloy 800 Elements (7.5 W/cm ²)	240	67.0	3	4	CFRN726D3XS	C4-148	C4-149	358 (163)	55 ¹ / ₄ (1402.0)	32 ³ / ₄ (830.0)	29 ¹ / ₄ (741.0)
	480	67.0	1	3	CFRN726D11XS	C/F	C/F	358 (163)	55 ¹ / ₄ (1402.0)	32 ³ / ₄ (830.0)	29 ¹ / ₄ (741.0)
	480	67.0	3	2	CFRN726D5XS	C2-229	C2-230	358 (163)	55 ¹ / ₄ (1402.0)	32 ³ / ₄ (830.0)	29 ¹ / ₄ (741.0)
	240	100.0	3	8	CFRN736D3XS	C/F	C/F	392 (178)	62 ¹ / ₄ (1580.0)	39 ³ / ₄ (1008.0)	36 ¹ / ₄ (919.0)
	480	100.0	3	4	CFRN736D5XS	C4-156	C4-157	392 (178)	62 ¹ / ₄ (1580.0)	39 ³ / ₄ (1008.0)	36 ¹ / ₄ (919.0)
	240	133.0	3	8	CFRN744M3XS	C/F	C/F	425 (193)	69 ⁷ / ₈ (1774.8)	47 ³ / ₈ (1203.3)	43 ⁷ / ₈ (1114.4)
	480	133.0	3	4	CFRN744M5XS	C4-156	C4-157	425 (193)	69 ⁷ / ₈ (1774.8)	47 ³ / ₈ (1203.3)	43 ⁷ / ₈ (1114.4)
	240	167.0	3	8	CFRN754M3XS	C/F	C/F	463 (210)	79 ³ / ₈ (2016.1)	56 ⁷ / ₈ (1444.6)	53 ³ / ₈ (1355.7)
	480	167.0	3	8	CFRN754M5XS	C/F	C/F	463 (210)	79 ³ / ₈ (2016.1)	56 ⁷ / ₈ (1444.6)	53 ³ / ₈ (1355.7)
	480	200.0	3	8	CFRN763M5XS	C/F	C/F	511 (232)	88 ³ / ₈ (2244.7)	65 ⁷ / ₈ (1673.2)	62 ³ / ₈ (1584.3)
	480	233.0	3	8	CFRN773D5XS	C/F	C/F	554 (252)	98 ³ / ₈ (2498.7)	75 ⁷ / ₈ (1927.2)	72 ³ / ₈ (1838.3)
480	267.0	3	8	CFRN782M5XS	C/F	C/F	587 (267)	98 ³ / ₈ (2498.7)	75 ⁷ / ₈ (1927.2)	72 ³ / ₈ (1838.3)	

⑤ When steel vessel materials are used in this application, some rust may be present in the process media

C/F - Contact factory, go to www.watlow.com/en/contact-us

8 inch - 150 lb ANSI Flange

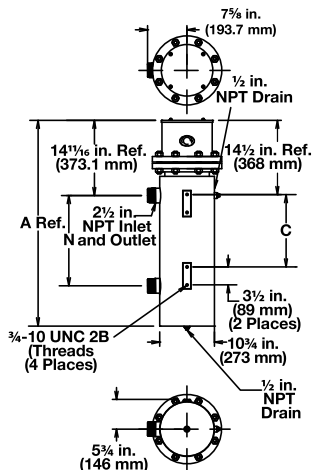

Circulation Heaters



WATROD and FIREBAR Circulation Heaters



Application: Process Water®

- WATROD elements
- Without thermostat
- General purpose enclosure

Description	Volts	kW	Ph	# Circ.	Part Number	WATCONNECT Part Number		Ship Wt. lbs (kg)	"A" Dim. in. (mm)		"N" Dim. in. (mm)		"C" Dim. in. (mm)	
						Type J T/C	Type K T/C							
10 inch - 150 lb ANSI Flange (WATROD)														
48 W/in ² Ⓢ Steel Tank 27-Alloy 800 Elements (7.5 W/cm ²)	480	262.0	3	9	CFSN773E5S	C/F	C/F	600 (273)	106 ⁵ / ₈ (2708.3)		90 ⁷ / ₈ (2308.2)		97 ⁵ / ₁₆ (2471.7)	
12 inch, 150 lb ANSI Flange (WATROD)														
48 W/in ² Steel Tank 36-Alloy 800 Elements (7.5 W/cm ²)	480	350.0	3	12	CFTN773C5S	C/F	C/F	650 (295)	106 ¹ / ₂ (2705)		90 ³ / ₈ (2295.5)		97 ¹ / ₈ (2467.0)	
14 inch - 150 lb ANSI Flange (WATROD)														
48 W/in ² Steel Tank 45-Alloy 800 Elements (7.5 W/cm ²)	480	315.0	3	15	CFWN754J5S	C/F	C/F	600 (273)	83 ¹ / ₄ (2115)		67 (1700)		73 ¹¹ / ₁₆ (1871.7)	
	480	375.0	3	15	CFWN763J5S	C/F	C/F	650 (295)	90 ³ / ₄ (2305)		74 ¹ / ₂ (1891)		81 ³ / ₁₆ (2062.2)	

Ⓢ When steel vessel materials are used in this application, some rust may be present in the process media

Ⓢ Can be wired for 1-phase operation

C/F - Contact factory, go to www.watlow.com/en/contact-us

10 inch - 150 lb ANSI Flange

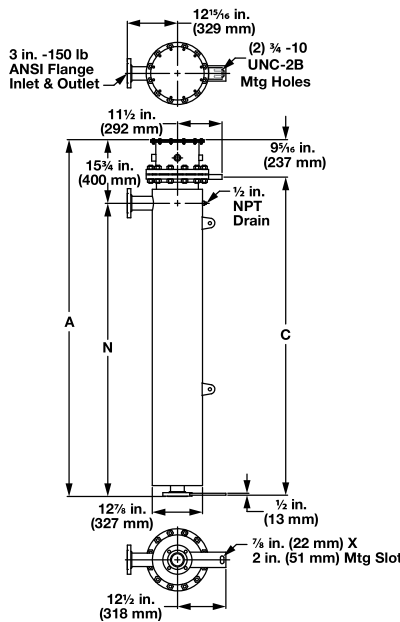

12 inch - 150 lb ANSI Flange

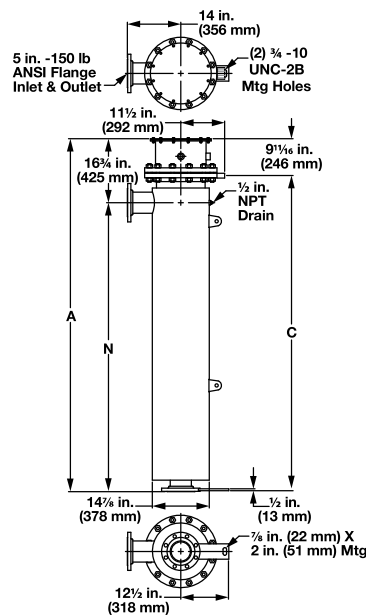

14 inch - 150 lb ANSI Flange

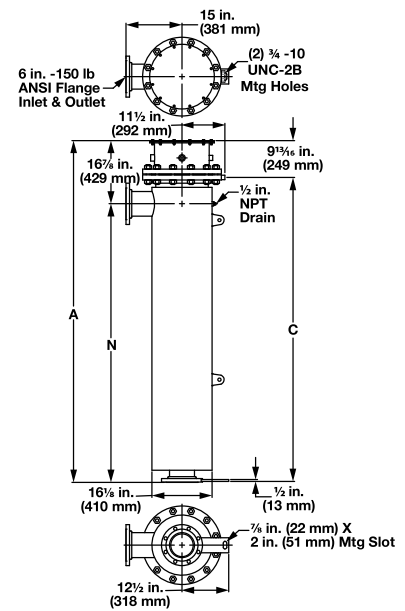



Circulation Heaters

WATROD and FIREBAR Circulation Heaters

Application: Forced Air and Caustic Solutions

- WATROD elements
- Without thermostat
- General purpose enclosure

Description	Volts	kW	Ph	# Circ.	Part Number	WATCONNECT Part Number		Ship Wt. lbs (kg)	"A" Dim. in. (mm)	"N" Dim. in. (mm)	"C" Dim. in. (mm)
						Type J T/C	Type K T/C				
1 1/4 inch NPT Screw Plug (WATROD)											
23 W/in² ④ Steel Tank 2-Alloy 800 Elements (3.6 W/cm²)	120	1.0	1	1	CBEN13G6S	C1-15	C1-12	21 (10)	24 ⁵ / ₈ (625.5)	15 (381)	3 ¹ / ₈ (79.4)
	240	1.0	1	1	CBEN13G6S	C1-17	C1-13	21 (10)	24 ⁵ / ₈ (625.5)	15 (381)	3 ¹ / ₈ (79.4)
	120	1.5	1	1	CBEN19A6S	C1-15	C1-12	29 (14)	24 ⁵ / ₈ (625.5)	15 (381)	3 ¹ / ₈ (79.4)
	240	1.5	1	1	CBEN19A6S	C1-17	C1-13	29 (14)	24 ⁵ / ₈ (625.5)	15 (381)	3 ¹ / ₈ (79.4)
	120	2.0	1	1	CBEN24G6S	C1-15	C1-12	29 (14)	32 ⁵ / ₈ (828.7)	23 (584)	3 ¹ / ₈ (79.4)
	240	2.0	1	1	CBEN24G6S	C1-17	C1-13	29 (14)	32 ⁵ / ₈ (828.7)	23 (584)	3 ¹ / ₈ (79.4)
2 1/2 inch NPT Screw Plug (WATROD)											
23 W/in² Steel Tank 3-Alloy 800 Elements (3.6 W/cm²)	240	3.0	3	1	CBLNA17G3S	C2-50	C2-92	24 (11)	34 ³ / ₄ (881)	22 ¹ / ₂ (572)	16 ¹ / ₂ (419)
	480	3.0	3	1	CBLNA17G5S	C2-43	C2-35	24 (11)	34 ³ / ₄ (881)	22 ¹ / ₂ (572)	16 ¹ / ₂ (419)
	240	4.5	3	1	CBLNA24R3S	C2-50	C2-92	27 (13)	44 ³ / ₄ (1135)	32 ¹ / ₂ (826)	26 ¹ / ₂ (673)
	480	4.5	3	1	CBLNA24R5S	C2-43	C2-35	27 (13)	44 ³ / ₄ (1135)	32 ¹ / ₂ (826)	26 ¹ / ₂ (673)
	240	6.0	3	1	CBLNA32G3S	C2-50	C2-92	29 (14)	44 ³ / ₄ (1135)	32 ¹ / ₂ (826)	26 ¹ / ₂ (673)
	480	6.0	3	1	CBLNA32G5S	C2-43	C2-35	29 (14)	44 ³ / ₄ (1135)	32 ¹ / ₂ (826)	26 ¹ / ₂ (673)
	240	7.5	3	1	CBLNA39R3S	C2-50	C2-92	31 (14)	57 ¹ / ₄ (1453)	45 (1143)	39 (991)
	480	7.5	3	1	CBLNA39R5S	C2-43	C2-35	31 (14)	57 ¹ / ₄ (1453)	45 (1143)	39 (991)
	240	9.0	3	1	CBLNA47G3S	C2-50	C2-92	32 (15)	57 ¹ / ₄ (1453)	45 (1143)	39 (991)
	480	9.0	3	1	CBLNA47G5S	C2-43	C2-35	32 (15)	57 ¹ / ₄ (1453)	45 (1143)	39 (991)

④ Wired for higher voltage

1 1/4 inch NPT Screw Plug

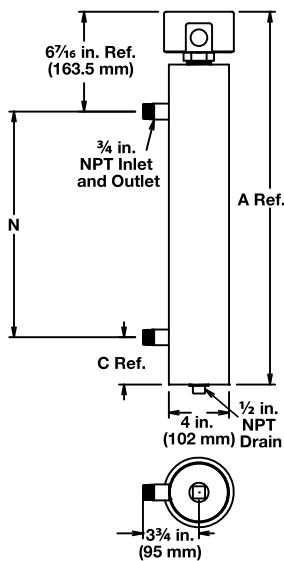

2 1/2 inch NPT Screw Plug

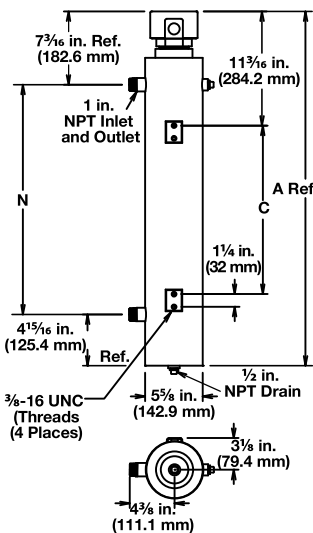



Circulation Heaters

WATROD and FIREBAR Circulation Heaters



Application: Forced Air and Caustic Solutions

- WATROD elements
- Without thermostat
- General purpose enclosure

Description	Volts	kW	Ph	# Circ.	Part Number	WATCONNECT Part Number		Ship Wt. lbs (kg)	"A" Dim. in. (mm)	"N" Dim. in. (mm)	"C" Dim. in. (mm)
						Type J T/C	Type K T/C				
3 inch - 150 lb ANSI Flange (WATROD)											
23 W/in² Steel Tank 3-Alloy 800 Elements (3.6 W/cm²)	240	3.0	1	1	CFMNA18A10S	C1-17	C1-13	68 (31)	35 ¹ / ₄ (894)	22 ¹ / ₂ (573)	16 ¹ / ₂ (419)
	240	3.0	3	1	CFMNA18A3S	C2-50	C2-92	68 (31)	35 ¹ / ₄ (894)	22 ¹ / ₂ (573)	16 ¹ / ₂ (419)
	480	3.0	1	1	CFMNA18A11S	C/F	C/F	68 (31)	35 ¹ / ₄ (894)	22 ¹ / ₂ (573)	16 ¹ / ₂ (419)
	480	3.0	3	1	CFMNA18A5S	C2-43	C2-35	68 (31)	35 ¹ / ₄ (894)	22 ¹ / ₂ (573)	16 ¹ / ₂ (419)
	240	4.5	1	1	CFMNA25J10S	C/F	C/F	78 (36)	45 ¹ / ₄ (1148)	32 ¹ / ₂ (826)	26 ¹ / ₂ (673)
	240	4.5	3	1	CFMNA25J3S	C2-50	C2-92	78 (36)	45 ¹ / ₄ (1148)	32 ¹ / ₂ (826)	26 ¹ / ₂ (673)
	480	4.5	1	1	CFMNA25J11S	C/F	C/F	78 (36)	45 ¹ / ₄ (1148)	32 ¹ / ₂ (826)	26 ¹ / ₂ (673)
	480	4.5	3	1	CFMNA25J5S	C2-43	C2-35	78 (36)	45 ¹ / ₄ (1148)	32 ¹ / ₂ (826)	26 ¹ / ₂ (673)
	240	6.0	1	1	CFMNA33A10S	C/F	C/F	96 (44)	45 ¹ / ₄ (1148)	32 ¹ / ₂ (826)	26 ¹ / ₂ (673)
	240	6.0	3	1	CFMNA33A3S	C2-50	C2-92	96 (44)	45 ¹ / ₄ (1148)	32 ¹ / ₂ (826)	26 ¹ / ₂ (673)
	480	6.0	1	1	CFMNA33A11S	C/F	C/F	96 (44)	45 ¹ / ₄ (1148)	32 ¹ / ₂ (826)	26 ¹ / ₂ (673)
	480	6.0	3	1	CFMNA33A5S	C2-43	C2-35	96 (44)	45 ¹ / ₄ (1148)	32 ¹ / ₂ (826)	26 ¹ / ₂ (673)
	240	7.5	1	1	CFMNA40J10S	C/F	C/F	100 (46)	57 ³ / ₄ (1465)	45 (1143)	39 (991)
	240	7.5	3	1	CFMNA40J3S	C2-50	C2-92	100 (46)	57 ³ / ₄ (1465)	45 (1143)	39 (991)
	480	7.5	1	1	CFMNA40J11S	C/F	C/F	100 (46)	57 ³ / ₄ (1465)	45 (1143)	39 (991)
	480	7.5	3	1	CFMNA40J5S	C2-43	C2-35	100 (46)	57 ³ / ₄ (1465)	45 (1143)	39 (991)
	240	9.0	1	1	CFMNA48A10S	C/F	C/F	107 (49)	57 ³ / ₄ (1465)	45 (1143)	39 (991)
	240	9.0	3	1	CFMNA48A3S	C2-50	C2-92	107 (49)	57 ³ / ₄ (1465)	45 (1143)	39 (991)
	480	9.0	1	1	CFMNA48A11S	C/F	C/F	107 (49)	57 ³ / ₄ (1465)	45 (1143)	39 (991)
	480	9.0	3	1	CFMNA48A5S	C2-43	C2-35	107 (49)	57 ³ / ₄ (1465)	45 (1143)	39 (991)

C/F - Contact factory, go to www.watlow.com/en/contact-us

3 inch - 150 lb ANSI Flange

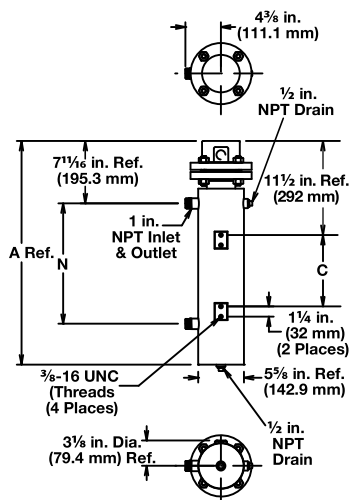



Circulation Heaters

WATROD and FIREBAR Circulation Heaters

Application: Forced Air and Caustic Solutions

- WATROD elements
- Without thermostat
- General purpose enclosure

Description	Volts	kW	Ph	# Circ.	Part Number	WATCONNECT Part Number		Ship Wt. lbs (kg)	"A" Dim. in. (mm)		"N" Dim. in. (mm)		"C" Dim. in. (mm)	
						Type J T/C	Type K T/C							
4 inch - 150 lb ANSI Flange (WATROD)														
23 W/in² ⑥ Steel Tank 6-Alloy 800 Elements (3.6 W/cm²)	240	6.0	1	1	CFONA18A10S	C/F	C/F	125 (57)	39 (989)	20 ¹ / ₂ (521)	17 (432)			
	240	6.0	3	1	CFONA18A3S	C2-50	C2-92	125 (57)	39 (989)	20 ¹ / ₂ (521)	17 (432)			
	480	6.0	1	1	CFONA18A11S	C/F	C/F	125 (57)	39 (989)	20 ¹ / ₂ (521)	17 (432)			
	480	6.0	3	1	CFONA18A5S	C2-43	C2-35	125 (57)	39 (989)	20 ¹ / ₂ (521)	17 (432)			
	240	9.0	1	1	CFONA25J10S	C/F	C/F	160 (73)	39 (989)	20 ¹ / ₂ (521)	17 (432)			
	240	9.0	3	1	CFONA25J3S	C2-50	C2-92	160 (73)	39 (989)	20 ¹ / ₂ (521)	17 (432)			
	480	9.0	1	1	CFONA25J11S	C/F	C/F	160 (73)	39 (989)	20 ¹ / ₂ (521)	17 (432)			
	480	9.0	3	1	CFONA25J5S	C2-43	C2-35	160 (73)	39 (989)	20 ¹ / ₂ (521)	17 (432)			
	240	12.0	1	2	CFONA33A10S	C/F	C/F	163 (74)	49 ¹ / ₂ (1256)	31 (787)	27 ¹ / ₂ (699)			
	240	12.0	3	1	CFONA33A3S	C2-236	C2-214	163 (74)	49 ¹ / ₂ (1256)	31 (787)	27 ¹ / ₂ (699)			
	480	12.0	1	1	CFONA33A11S	C/F	C/F	163 (74)	49 ¹ / ₂ (1256)	31 (787)	27 ¹ / ₂ (699)			
	480	12.0	3	1	CFONA33A5S	C2-43	C2-35	163 (74)	49 ¹ / ₂ (1256)	31 (787)	27 ¹ / ₂ (699)			
	240	15.0	1	2	CFONA40J10S	C/F	C/F	229 (104)	70 ¹ / ₂ (1789)	52 (1321)	48 ¹ / ₂ (1232)			
	240	15.0	3	1	CFONA40J3S	C2-236	C2-214	229 (104)	70 ¹ / ₂ (1789)	52 (1321)	48 ¹ / ₂ (1232)			
	480	15.0	1	1	CFONA40J11S	C/F	C/F	229 (104)	70 ¹ / ₂ (1789)	52 (1321)	48 ¹ / ₂ (1232)			
	480	15.0	3	1	CFONA40J5S	C2-43	C2-35	229 (104)	70 ¹ / ₂ (1789)	52 (1321)	48 ¹ / ₂ (1232)			
	240	18.0	1	2	CFONA48A10S	C/F	C/F	234 (107)	70 ¹ / ₂ (1789)	52 (1321)	48 ¹ / ₂ (1232)			
	240	18.0	3	1	CFONA48A3S	C2-236	C2-214	234 (107)	70 ¹ / ₂ (1789)	52 (1321)	48 ¹ / ₂ (1232)			
	480	18.0	1	1	CFONA48A11S	C/F	C/F	234 (107)	70 ¹ / ₂ (1789)	52 (1321)	48 ¹ / ₂ (1232)			
	480	18.0	3	1	CFONA48A5S	C2-43	C2-35	234 (107)	70 ¹ / ₂ (1789)	52 (1321)	48 ¹ / ₂ (1232)			
240	25.0	3	2	CFONA64J3S	C2-236	C2-214	298 (136)	91 ¹ / ₂ (2326)	73 (1854)	66 (1676)				
480	25.0	1	2	CFONA64J11S	C/F	C/F	298 (136)	91 ¹ / ₂ (2326)	73 (1854)	66 (1676)				
480	25.0	3	1	CFONA64J5S	C2-225	C2-226	298 (136)	91 ¹ / ₂ (2326)	73 (1854)	66 (1676)				
240	30.0	3	2	CFONA77A3S	C2-236	C2-214	306 (139)	91 ¹ / ₂ (2326)	73 (1854)	66 (1676)				
480	30.0	1	2	CFONA77A11S	C/F	C/F	306 (139)	91 ¹ / ₂ (2326)	73 (1854)	66 (1676)				
480	30.0	3	1	CFONA77A5S	C2-225	C2-226	306 (139)	91 ¹ / ₂ (2326)	73 (1854)	66 (1676)				

⑥ Can be wired 3-phase wye to produce 1/3 of the rated kW and watt density C/F - Contact factory, go to www.watlow.com/en/contact-us

4 inch - 150 lb ANSI Flange

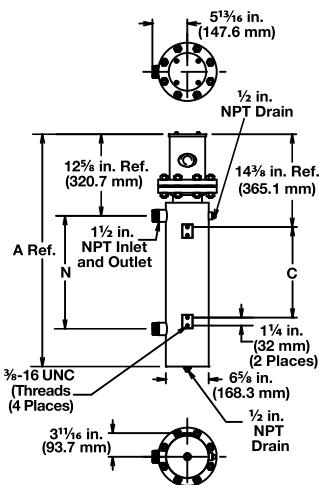



Circulation Heaters

WATROD and FIREBAR Circulation Heaters



Application: Forced Air and Caustic Solutions

- WATROD elements
- Without thermostat
- General purpose enclosure

Description	Volts	kW	Ph	# Circ.	Part Number	WATCONNECT Part Number		Ship Wt. lbs (kg)	"A" Dim. in. (mm)		"N" Dim. in. (mm)		"C" Dim. in. (mm)	
						Type J T/C	Type K T/C							
5 inch - 150 lb ANSI Flange (WATROD)														
23 W/in² ⑥ Steel Tank 6-Alloy 800 Elements (3.6 W/cm²)	240	9.0	1	1	CFNNA25J10S	C/F	C/F	140 (64)	49 ¹ / ₄ (1249.0)	30 (762.0)	14 ⁷ / ₈ (377.8)			
	240	9.0	3	1	CFNNA25J3S	C2-50	C2-92	140 (64)	49 ¹ / ₄ (1249.0)	30 (762.0)	14 ⁷ / ₈ (377.8)			
	480	9.0	1	1	CFNNA25J11S	C/F	C/F	140 (64)	49 ¹ / ₄ (1249.0)	30 (762.0)	14 ⁷ / ₈ (377.8)			
	480	9.0	3	1	CFNNA25J5S	C2-43	C2-35	140 (64)	49 ¹ / ₄ (1249.0)	30 (762.0)	14 ⁷ / ₈ (377.8)			
	240	12.0	1	2	CFNNA33A10S	C/F	C/F	145 (66)	56 ¹ / ₄ (1427.0)	37 (940.0)	18 ⁵ / ₈ (473.1)			
	240	12.0	3	1	CFNNA33A3S	C2-236	C2-214	145 (66)	56 ¹ / ₄ (1427.0)	37 (940.0)	18 ⁵ / ₈ (473.1)			
	480	12.0	1	1	CFNNA33A11S	C/F	C/F	145 (66)	56 ¹ / ₄ (1427.0)	37 (940.0)	18 ⁵ / ₈ (473.1)			
	480	12.0	3	1	CFNNA33A5S	C2-43	C2-35	145 (66)	56 ¹ / ₄ (1427.0)	37 (940.0)	18 ⁵ / ₈ (473.1)			
	240	15.0	1	2	CFNNA40J10S	C/F	C/F	167 (76)	56 ¹ / ₄ (1427.0)	37 (940.0)	18 ⁵ / ₈ (473.1)			
	240	15.0	3	1	CFNNA40J3S	C2-236	C2-214	167 (76)	56 ¹ / ₄ (1427.0)	37 (940.0)	18 ⁵ / ₈ (473.1)			
	480	15.0	1	1	CFNNA40J11S	C/F	C/F	167 (76)	56 ¹ / ₄ (1427.0)	37 (940.0)	18 ⁵ / ₈ (473.1)			
	480	15.0	3	1	CFNNA40J5S	C2-43	C2-35	167 (76)	56 ¹ / ₄ (1427.0)	37 (940.0)	18 ⁵ / ₈ (473.1)			
	240	18.0	1	2	CFNNA48A10S	C/F	C/F	180 (82)	67 ³ / ₄ (1719.0)	48 ¹ / ₂ (1232.0)	25 (633.0)			
	240	18.0	3	1	CFNNA48A3S	C2-236	C2-214	180 (82)	67 ³ / ₄ (1719.0)	48 ¹ / ₂ (1232.0)	25 (633.0)			
	480	18.0	1	1	CFNNA48A11S	C/F	C/F	180 (82)	67 ³ / ₄ (1719.0)	48 ¹ / ₂ (1232.0)	25 (633.0)			
	480	18.0	3	1	CFNNA48A5S	C2-43	C2-35	180 (82)	67 ³ / ₄ (1719.0)	48 ¹ / ₂ (1232.0)	25 (633.0)			
	240	25.0	3	2	CFNNA64J3S	C2-218	C2-224	195 (89)	81 ¹ / ₈ (2060.6)	61 ⁷ / ₈ (1571.6)	25 (633.0)			
	480	25.0	1	2	CFNNA64J11S	C/F	C/F	195 (89)	81 ¹ / ₈ (2060.6)	61 ⁷ / ₈ (1571.6)	25 (633.0)			
	480	25.0	3	1	CFNNA64J5S	C2-225	C2-226	195 (89)	81 ¹ / ₈ (2060.6)	61 ⁷ / ₈ (1571.6)	25 (633.0)			
	240	30.0	3	2	CFNNA77A3S	C2-218	C2-224	220 (100)	94 ¹ / ₈ (2390.8)	75 (1902.0)	25 (633.0)			
480	30.0	1	2	CFNNA77A11S	C/F	C/F	220 (100)	94 ¹ / ₈ (2390.8)	75 (1902.0)	25 (633.0)				
480	30.0	3	1	CFNNA77A5S	C2-225	C2-226	220 (100)	94 ¹ / ₈ (2390.8)	75 (1902.0)	25 (633.0)				

⑥ Can be wired 3-phase wye to produce 1/3 of the rated kW and watt density

C/F - Contact factory, go to www.watlow.com/en/contact-us

5 inch - 150 lb ANSI Flange

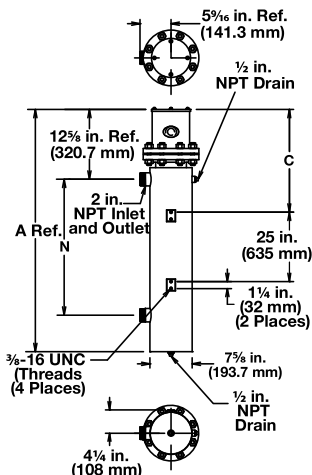

Circulation Heaters



WATROD and FIREBAR Circulation Heaters



Application: Forced Air and Caustic Solutions

- WATROD elements
- Without thermostat
- General purpose enclosure

Description	Volts	kW	Ph	# Circ.	Part Number	WATCONNECT Part Number		Ship Wt. lbs (kg)	"A" Dim. in. (mm)		"N" Dim. in. (mm)		"C" Dim. in. (mm)	
						Type J T/C	Type K T/C							
5 inch - 150 lb ANSI Flange (WATROD)														
23 W/in² ⑥ Steel Tank 9-Alloy 800 Elements (3.6 W/cm²)	240	14.0	1	3	CFNNA25J10XS	C/F	C/F	145 (66)	49 ¹ / ₄ (1249.0)	30	(762.0)	14 ⁷ / ₈ (377.8)		
	240	14.0	3	1	CFNNA25J3XS	C2-236	C2-214	145 (66)	49 ¹ / ₄ (1249.0)	30	(762.0)	14 ⁷ / ₈ (377.8)		
	480	14.0	1	1	CFNNA25J11XS	C/F	C/F	145 (66)	49 ¹ / ₄ (1249.0)	30	(762.0)	14 ⁷ / ₈ (377.8)		
	480	14.0	3	1	CFNNA25J5XS	C2-43	C2-35	145 (66)	49 ¹ / ₄ (1249.0)	30	(762.0)	14 ⁷ / ₈ (377.8)		
	240	18.0	1	3	CFNNA33A10XS	C/F	C/F	150 (68)	56 ¹ / ₄ (1427.0)	37	(940.0)	18 ⁵ / ₈ (473.1)		
	240	18.0	3	1	CFNNA33A3XS	C2-236	C2-214	150 (68)	56 ¹ / ₄ (1427.0)	37	(940.0)	18 ⁵ / ₈ (473.1)		
	480	18.0	1	1	CFNNA33A11XS	C/F	C/F	150 (68)	56 ¹ / ₄ (1427.0)	37	(940.0)	18 ⁵ / ₈ (473.1)		
	480	18.0	3	1	CFNNA33A5XS	C2-43	C2-35	150 (68)	56 ¹ / ₄ (1427.0)	37	(940.0)	18 ⁵ / ₈ (473.1)		
	240	23.0	1	3	CFNNA40J10XS	C/F	C/F	174 (79)	56 ¹ / ₄ (1427.0)	37	(940.0)	18 ⁵ / ₈ (473.1)		
	240	23.0	3	3	CFNNA40J3XS	C4-143	C4-142	174 (79)	56 ¹ / ₄ (1427.0)	37	(940.0)	18 ⁵ / ₈ (473.1)		
	480	23.0	1	1	CFNNA40J11XS	C/F	C/F	174 (79)	56 ¹ / ₄ (1427.0)	37	(940.0)	18 ⁵ / ₈ (473.1)		
	480	23.0	3	1	CFNNA40J5XS	C2-225	C2-226	174 (79)	56 ¹ / ₄ (1427.0)	37	(940.0)	18 ⁵ / ₈ (473.1)		
	240	27.0	1	3	CFNNA48A10XS	C/F	C/F	189 (86)	67 ³ / ₄ (1719.0)	48 ¹ / ₂ (1232.0)		25 (633.0)		
	240	27.0	3	3	CFNNA48A3XS	C4-143	C4-142	189 (86)	67 ³ / ₄ (1719.0)	48 ¹ / ₂ (1232.0)		25 (633.0)		
	480	27.0	1	3	CFNNA48A11XS	C/F	C/F	189 (86)	67 ³ / ₄ (1719.0)	48 ¹ / ₂ (1232.0)		25 (633.0)		
	480	27.0	3	1	CFNNA48A5XS	C2-225	C2-226	189 (86)	67 ³ / ₄ (1719.0)	48 ¹ / ₂ (1232.0)		25 (633.0)		
	240	38.0	3	3	CFNNA64J3XS	C4-144	C4-145	207 (94)	81 ¹ / ₈ (2060.6)	61 ⁷ / ₈ (1571.6)		25 (633.0)		
	480	38.0	1	3	CFNNA64J11XS	C/F	C/F	207 (94)	81 ¹ / ₈ (2060.6)	61 ⁷ / ₈ (1571.6)		25 (633.0)		
	480	38.0	3	1	CFNNA64J5XS	C2-225	C2-226	207 (94)	81 ¹ / ₈ (2060.6)	61 ⁷ / ₈ (1571.6)		25 (633.0)		
	240	45.0	3	3	CFNNA77A3XS	C4-144	C4-145	233 (106)	94 ¹ / ₈ (2389.0)	75 (1902.0)		25 (633.0)		
480	45.0	1	3	CFNNA77A11XS	C/F	C/F	233 (106)	94 ¹ / ₈ (2389.0)	75 (1902.0)		25 (633.0)			
480	45.0	3	3	CFNNA77A5XS	C4-150	C4-151	233 (106)	94 ¹ / ₈ (2389.0)	75 (1902.0)		25 (633.0)			

⑥ Can be wired 3-phase wye to produce 1/3 of the rated kW and watt density
C/F - Contact factory, go to www.watlow.com/en/contact-us

5 inch - 150 lb ANSI Flange

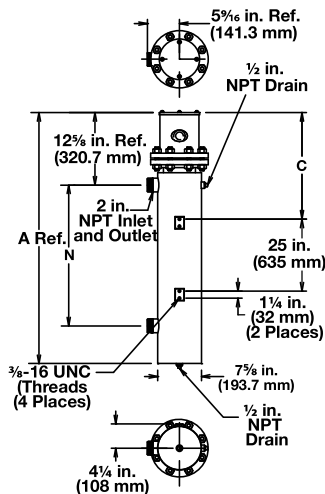



Circulation Heaters

WATROD and FIREBAR Circulation Heaters



Application: Forced Air and Caustic Solutions

- WATROD elements
- Without thermostat
- General purpose enclosure

Description	Volts	kW	Ph	# Circ.	Part Number	WATCONNECT Part Number		Ship Wt. lbs (kg)	"A" Dim. in. (mm)		"N" Dim. in. (mm)		"C" Dim. in. (mm)	
						Type J T/C	Type K T/C							
6 inch - 150 lb ANSI Flange (WATROD)														
23 W/in² ® Steel Tank 12-Alloy 800 Elements (3.6 W/cm²)	240	12.0	1	2	CFPNA17R10S	C/F	C/F	214 (97)	40 ¹ / ₂ (1027)	20 ¹ / ₂ (521)	17	(432)		
	240	12.0	3	1	CFPNA17R3S	C2-236	C2-214	214 (97)	40 ¹ / ₂ (1027)	20 ¹ / ₂ (521)	17	(432)		
	480	12.0	1	1	CFPNA17R11S	C/F	C/F	214 (97)	40 ¹ / ₂ (1027)	20 ¹ / ₂ (521)	17	(432)		
	480	12.0	3	1	CFPNA17R5S	C2-43	C2-35	214 (97)	40 ¹ / ₂ (1027)	20 ¹ / ₂ (521)	17	(432)		
	240	18.0	1	2	CFPNA25G10S	C/F	C/F	222 (101)	40 ¹ / ₂ (1027)	20 ¹ / ₂ (521)	17	(432)		
	240	18.0	3	1	CFPNA25G3S	C2-236	C2-214	222 (101)	40 ¹ / ₂ (1027)	20 ¹ / ₂ (521)	17	(432)		
	480	18.0	1	1	CFPNA25G11S	C/F	C/F	222 (101)	40 ¹ / ₂ (1027)	20 ¹ / ₂ (521)	17	(432)		
	480	18.0	3	1	CFPNA25G5S	C2-43	C2-35	222 (101)	40 ¹ / ₂ (1027)	20 ¹ / ₂ (521)	17	(432)		
	240	24.0	1	3	CFPNA32R10S	C/F	C/F	226 (103)	51 (1294)	31 (787)	27 ¹ / ₂	(699)		
	240	24.0	3	2	CFPNA32R3S	C2-218	C2-224	226 (103)	51 (1294)	31 (787)	27 ¹ / ₂	(699)		
	480	24.0	1	2	CFPNA32R11S	C/F	C/F	226 (103)	51 (1294)	31 (787)	27 ¹ / ₂	(699)		
	480	24.0	3	1	CFPNA32R5S	C2-225	C2-226	226 (103)	51 (1294)	31 (787)	27 ¹ / ₂	(699)		
	240	30.0	1	3	CFPNA40G10S	C/F	C/F	290 (132)	72 (1827)	52 (1321)	48 ¹ / ₂	(1232)		
	240	30.0	3	2	CFPNA40G3S	C2-218	C2-224	290 (132)	72 (1827)	52 (1321)	48 ¹ / ₂	(1232)		
	480	30.0	1	2	CFPNA40G11S	C/F	C/F	290 (132)	72 (1827)	52 (1321)	48 ¹ / ₂	(1232)		
	480	30.0	3	1	CFPNA40G5S	C2-225	C2-226	290 (132)	72 (1827)	52 (1321)	48 ¹ / ₂	(1232)		
	240	36.0	1	4	CFPNA47R10S	C/F	C/F	298 (136)	72 (1827)	52 (1321)	48 ¹ / ₂	(1232)		
	240	36.0	3	2	CFPNA47R3S	C2-218	C2-224	298 (136)	72 (1827)	52 (1321)	48 ¹ / ₂	(1232)		
	480	36.0	1	2	CFPNA47R11S	C/F	C/F	298 (136)	72 (1827)	52 (1321)	48 ¹ / ₂	(1232)		
	480	36.0	3	1	CFPNA47R5S	C2-225	C2-226	298 (136)	72 (1827)	52 (1321)	48 ¹ / ₂	(1232)		
240	50.0	3	4	CFPNA64G3S	C4-148	C4-149	360 (164)	93 (2361)	73 (1854)	66	(1676)			
480	50.0	1	3	CFPNA64G11S	C/F	C/F	360 (164)	93 (2361)	73 (1854)	66	(1676)			
480	50.0	3	2	CFPNA64G5S	C2-229	C2-230	360 (164)	93 (2361)	73 (1854)	66	(1676)			
240	60.0	3	4	CFPNA76R3S	C4-148	C4-149	368 (167)	93 (2361)	73 (1854)	66	(1676)			
480	60.0	1	3	CFPNA76R11S	C/F	C/F	368 (167)	93 (2361)	73 (1854)	66	(1676)			
480	60.0	3	2	CFPNA76R5S	C2-229	C2-230	368 (167)	93 (2361)	73 (1854)	66	(1676)			

® Can be wired 3-phase wye to produce 1/3 of the rated kW and watt density

C/F - Contact factory, go to www.watlow.com/en/contact-us

6 inch - 150 lb ANSI Flange

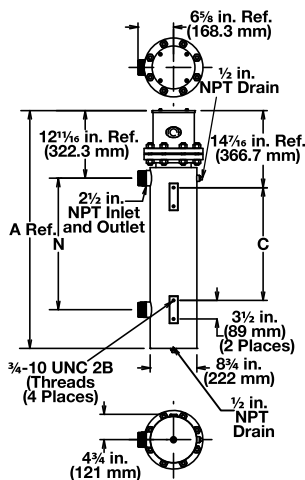



Circulation Heaters

WATROD and FIREBAR Circulation Heaters

Application: Forced Air and Caustic Solutions

- WATROD elements
- Without thermostat
- General purpose enclosure

Description	Volts	kW	Ph	# Circ.	Part Number	WATCONNECT Part Number		Ship Wt. lbs (kg)	"A" Dim. in. (mm)		"N" Dim. in. (mm)		"C" Dim. in. (mm)	
						Type J T/C	Type K T/C							
6 inch - 150 lb ANSI Flange (WATROD)														
23 W/in² Steel Tank 15-Alloy 800 Elements (3.6 W/cm²)	240	15.0	1	3	CFPNA17R10XS	C/F	C/F	217 (99)	40 ¹ / ₂ (1027)	20 ¹ / ₂ (521)	17	(432)		
	240	15.0	3	1	CFPNA17R3XS	C2-236	C2-214	217 (99)	40 ¹ / ₂ (1027)	20 ¹ / ₂ (521)	17	(432)		
	480	15.0	1	1	CFPNA17R11XS	C/F	C/F	217 (99)	40 ¹ / ₂ (1027)	20 ¹ / ₂ (521)	17	(432)		
	480	15.0	3	1	CFPNA17R5XS	C2-43	C2-35	217 (99)	40 ¹ / ₂ (1027)	20 ¹ / ₂ (521)	17	(432)		
	240	23.0	1	3	CFPNA25G10XS	C/F	C/F	226 (103)	40 ¹ / ₂ (1027)	20 ¹ / ₂ (521)	17	(432)		
	240	23.0	3	5	CFPNA25G3XS	C4-143	C4-142	226 (103)	40 ¹ / ₂ (1027)	20 ¹ / ₂ (521)	17	(432)		
	480	23.0	1	1	CFPNA25G11XS	C/F	C/F	226 (103)	40 ¹ / ₂ (1027)	20 ¹ / ₂ (521)	17	(432)		
	480	23.0	3	1	CFPNA25G5XS	C2-225	C2-226	226 (103)	40 ¹ / ₂ (1027)	20 ¹ / ₂ (521)	17	(432)		
	240	30.0	1	3	CFPNA32R10XS	C/F	C/F	288 (131)	51 (1294)	31 (787)	27 ¹ / ₂	(699)		
	240	30.0	3	5	CFPNA32R3XS	C4-144	C4-145	288 (131)	51 (1294)	31 (787)	27 ¹ / ₂	(699)		
	480	30.0	1	3	CFPNA32R11XS	C/F	C/F	288 (131)	51 (1294)	31 (787)	27 ¹ / ₂	(699)		
	480	30.0	3	1	CFPNA32R5XS	C2-224	C2-226	288 (131)	51 (1294)	31 (787)	27 ¹ / ₂	(699)		
	240	38.0	1	5	CFPNA40G10XS	C/F	C/F	296 (135)	72 (1827)	52 (1321)	48 ¹ / ₂	(1232)		
	240	38.0	3	5	CFPNA40G3XS	C4-144	C4-145	296 (135)	72 (1827)	52 (1321)	48 ¹ / ₂	(1232)		
	480	38.0	1	3	CFPNA40G11XS	C/F	C/F	296 (135)	72 (1827)	52 (1321)	48 ¹ / ₂	(1232)		
	480	38.0	3	1	CFPNA40G5XS	C2-225	C2-226	296 (135)	72 (1827)	52 (1321)	48 ¹ / ₂	(1232)		
	240	45.0	1	5	CFPNA47R10XS	C/F	C/F	306 (139)	72 (1827)	52 (1321)	48 ¹ / ₂	(1232)		
	240	45.0	3	5	CFPNA47R3XS	C4-144	C4-145	306 (139)	72 (1827)	52 (1321)	48 ¹ / ₂	(1232)		
	480	45.0	1	3	CFPNA47R11XS	C/F	C/F	306 (139)	72 (1827)	52 (1321)	48 ¹ / ₂	(1232)		
	480	45.0	3	5	CFPNA47R5XS	C4-152	C4-153	306 (139)	72 (1827)	52 (1321)	48 ¹ / ₂	(1232)		
	240	63.0	3	5	CFPNA64G3XS	C/F	C/F	370 (168)	93 (2361)	73 (1854)	66	(1676)		
	480	63.0	1	3	CFPNA64G11XS	C/F	C/F	370 (168)	93 (2361)	73 (1854)	66	(1676)		
	480	63.0	3	5	CFPNA64G5XS	C4-152	C4-153	370 (168)	93 (2361)	73 (1854)	66	(1676)		
240	75.0	3	5	CFPNA76R3XS	C/F	C/F	381 (173)	93 (2361)	73 (1854)	66	(1676)			
480	75.0	1	5	CFPNA76R11XS	C/F	C/F	381 (173)	93 (2361)	73 (1854)	66	(1676)			
480	75.0	3	5	CFPNA76R5XS	C4-152	C4-153	381 (173)	93 (2361)	73 (1854)	66	(1676)			

C/F - Contact factory, go to www.watlow.com/en/contact-us

6 inch - 150 lb ANSI Flange

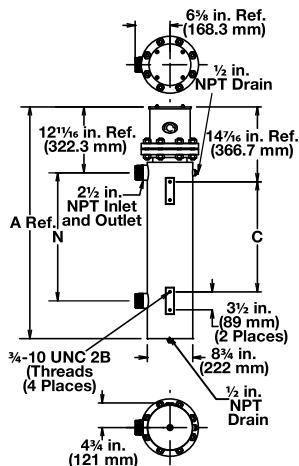

Circulation Heaters



WATROD and FIREBAR Circulation Heaters



Application: Forced Air and Caustic Solutions

- WATROD elements
- Without thermostat
- General purpose enclosure

Description	Volts	kW	Ph	# Circ.	Part Number	WATCONNECT Part Number		Ship Wt. lbs (kg)	"A" Dim. in. (mm)	"N" Dim. in. (mm)	"C" Dim. in. (mm)
						Type J T/C	Type K T/C				
8 inch - 150 lb ANSI Flange (WATROD)											
23 W/in² Steel Tank 18-Alloy 800 Elements (3.6 W/cm²)	240	30.0	1	3	CFRNA32N10S	C/F	C/F	370 (168)	55 ¹ / ₄ (1402.0)	32 ³ / ₄ (830.0)	29 ¹ / ₄ (741.0)
	240	30.0	3	2	CFRNA32N3S	C2-218	C2-224	370 (168)	55 ¹ / ₄ (1402.0)	32 ³ / ₄ (830.0)	29 ¹ / ₄ (741.0)
	480	30.0	1	2	CFRNA32N11S	C/F	C/F	370 (168)	55 ¹ / ₄ (1402.0)	32 ³ / ₄ (830.0)	29 ¹ / ₄ (741.0)
	480	30.0	3	1	CFRNA32N5S	C2-225	C2-226	370 (168)	55 ¹ / ₄ (1402.0)	32 ³ / ₄ (830.0)	29 ¹ / ₄ (741.0)
	240	40.0	3	3	CFRNA43E3S	C4-144	C4-145	410 (186)	62 ¹ / ₄ (1580.0)	39 ³ / ₄ (1008.0)	36 ¹ / ₄ (919.0)
	480	40.0	1	2	CFRNA43E11S	C/F	C/F	410 (186)	62 ¹ / ₄ (1580.0)	39 ³ / ₄ (1008.0)	36 ¹ / ₄ (919.0)
	480	40.0	3	3	CFRNA43E5S	C4-150	C4-151	410 (186)	62 ¹ / ₄ (1580.0)	39 ³ / ₄ (1008.0)	36 ¹ / ₄ (919.0)
	240	50.0	3	3	CFRNA51M3S	C4-144	C4-145	440 (200)	69 ⁷ / ₈ (1774.8)	47 ³ / ₈ (1203.3)	43 ⁷ / ₈ (1114.4)
	480	50.0	1	3	CFRNA51M11S	C/F	C/F	440 (200)	69 ⁷ / ₈ (1774.8)	47 ³ / ₈ (1203.3)	43 ⁷ / ₈ (1114.4)
480	50.0	3	2	CFRNA51M5S	C2-229	C2-230	440 (200)	69 ⁷ / ₈ (1774.8)	47 ³ / ₈ (1203.3)	43 ⁷ / ₈ (1114.4)	
8 inch - 150 lb ANSI Flange (WATROD)											
23 W/in² Steel Tank 24-Alloy 800 Elements (3.6 W/cm²)	240	40.0	1	4	CFRNA33D10XS	C/F	C/F	382 (174)	55 ¹ / ₄ (1402.0)	32 ³ / ₄ (830.0)	29 ¹ / ₄ (741.0)
	240	40.0	3	4	CFRNA33D3XS	C4-146	C4-147	382 (174)	55 ¹ / ₄ (1402.0)	32 ³ / ₄ (830.0)	29 ¹ / ₄ (741.0)
	480	40.0	1	2	CFRNA33D11XS	C/F	C/F	382 (174)	55 ¹ / ₄ (1402.0)	32 ³ / ₄ (830.0)	29 ¹ / ₄ (741.0)
	480	40.0	3	2	CFRNA33D5XS	C2-227	C2-228	382 (174)	55 ¹ / ₄ (1402.0)	32 ³ / ₄ (830.0)	29 ¹ / ₄ (741.0)
	240	53.0	3	4	CFRNA43M3XS	C4-148	C4-149	425 (193)	62 ¹ / ₄ (1580.0)	39 ³ / ₄ (1008.0)	36 ¹ / ₄ (919.0)
	480	53.0	1	3	CFRNA43M11XS	C/F	C/F	425 (193)	62 ¹ / ₄ (1580.0)	39 ³ / ₄ (1008.0)	36 ¹ / ₄ (919.0)
	480	53.0	3	2	CFRNA43M5XS	C2-229	C2-230	425 (193)	62 ¹ / ₄ (1580.0)	39 ³ / ₄ (1008.0)	36 ¹ / ₄ (919.0)
	240	67.0	3	4	CFRNA51M3XS	C4-148	C4-149	457 (207)	69 ⁷ / ₈ (1774.8)	47 ³ / ₈ (1203.3)	43 ⁷ / ₈ (1114.4)
	480	67.0	1	3	CFRNA51M11XS	C/F	C/F	457 (207)	69 ⁷ / ₈ (1774.8)	47 ³ / ₈ (1203.3)	43 ⁷ / ₈ (1114.4)
480	67.0	3	2	CFRNA51M5XS	C2-229	C2-230	457 (207)	69 ⁷ / ₈ (1774.8)	47 ³ / ₈ (1203.3)	43 ⁷ / ₈ (1114.4)	

C/F - Contact factory, go to www.watlow.com/en/contact-us

8 inch - 150 lb ANSI Flange

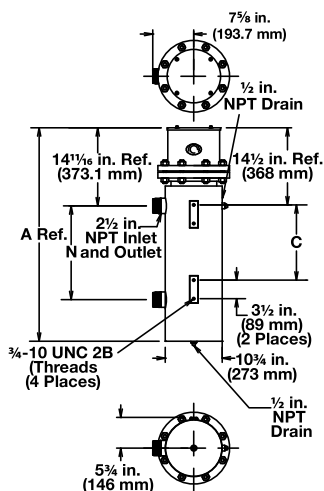

Circulation Heaters



WATROD and FIREBAR Circulation Heaters



Application: Forced Air and Caustic Solutions

- WATROD elements
- Without thermostat
- General purpose enclosure

Description	Volts	kW	Ph	# Circ.	Part Number	WATCONNECT Part Number		Ship Wt. lbs (kg)	"A" Dim. in. (mm)	"N" Dim. in. (mm)	"C" Dim. in. (mm)
						Type J T/C	Type K T/C				
10 inch - 150 lb ANSI Flange (WATROD)											
23 W/in² Steel Tank 27-Alloy 800 Elements (3.6 W/cm²)	240	60.0	3	3	CFSNA43N3S	C4-144	C4-145	515 (234)	76 ⁵ / ₈ (1946.3)	60 ⁷ / ₈ (1546.2)	67 ⁵ / ₁₆ (1709.7)
	480	60.0	3	3	CFSNA43N5S	C4-150	C4-151	515 (234)	76 ⁵ / ₈ (1946.3)	60 ⁷ / ₈ (1546.2)	67 ⁵ / ₁₆ (1709.7)
	240	75.0	3	9	CFSNA51N3S	C/F	C/F	530 (241)	84 ¹ / ₈ (2136.8)	68 ³ / ₈ (1736.2)	74 ¹³ / ₁₆ (1900.2)
	480	75.0	3	3	CFSNA51N5S	C4-152	C4-153	530 (241)	84 ¹ / ₈ (2136.8)	68 ³ / ₈ (1736.2)	74 ¹³ / ₁₆ (1900.2)
12 inch - 150 lb ANSI Flange (WATROD)											
23 W/in² Steel Tank 36-Alloy 800 Elements (3.6 W/cm²)	480	80.0	3	3	CFTNA43L5S	C4-152	C4-153	565 (257)	76 ⁷ / ₈ (1952.6)	60 ³ / ₄ (1541)	67 ¹ / ₂ (1714.0)
	480	100.0	3	3	CFTNA51L5S	C4-152	C4-153	585 (266)	84 ³ / ₈ (2143.1)	68 ¹ / ₄ (1732)	75 (1905.0)
14 inch - 150 lb ANSI Flange (WATROD)											
23 W/in² Steel Tank 45-Alloy 800 Elements (3.6 W/cm²)	480	100.0	3	3	CFWNA43J5S	C4-152	C4-153	570 (259)	75 ³ / ₄ (1924)	59 ¹ / ₂ (1510)	66 ³ / ₁₆ (1681.2)
	480	125.0	3	5	CFWNA51J5S	C/F	C/F	590 (268)	83 ¹ / ₄ (2115)	67 (1700)	73 ¹¹ / ₁₆ (1871.7)

C/F - Contact factory, go to www.watlow.com/en/contact-us

10 inch - 150 lb ANSI Flange

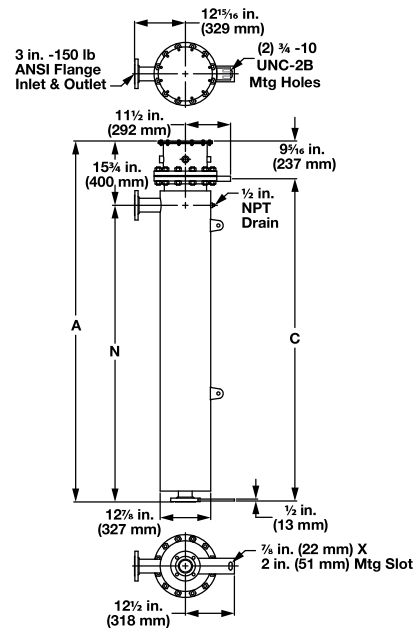

12 inch - 150 lb ANSI Flange

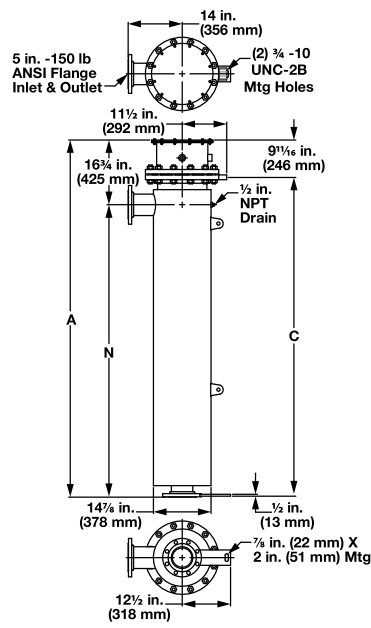

14 inch - 150 lb ANSI Flange

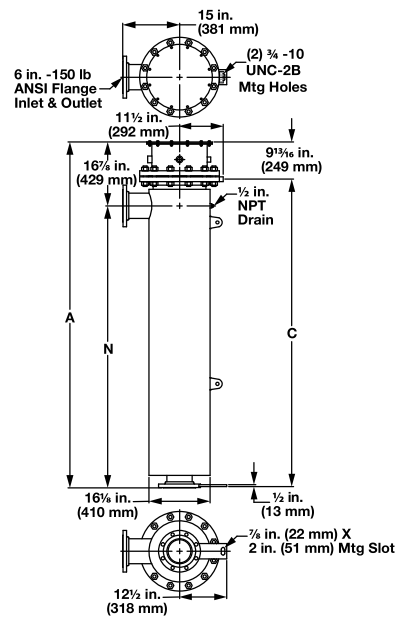

Circulation Heaters



WATROD and FIREBAR Circulation Heaters



Application: Lightweight Oils and Heat Transfer Oils

- WATROD or FIREBAR elements
- Without thermostat
- General purpose enclosure

Description	Volts	kW	Ph	# Circ.	Part Number	WATCONNECT Part Number		Ship Wt. lbs (kg)	"A" Dim. in. (mm)	"N" Dim. in. (mm)	"C" Dim. in. (mm)	
						Type J T/C	Type K T/C					
1 1/4 inch NPT Screw Plug (WATROD)												
23 W/in² Steel Tank 2-Steel Element (3.6 W/cm²)	120	1.5	1	1	CBES19G6S	C1-15	C1-12	29 (14)	24 ⁵ / ₈ (625.5)	15 (381)	3 ¹ / ₈ (79.4)	
	240	1.5	1	1	CBES19G6S	C1-17	C1-13	29 (14)	24 ⁵ / ₈ (625.5)	15 (381)	3 ¹ / ₈ (79.4)	
	120	2.0	1	1	CBES25G6S	C1-15	C1-12	29 (14)	32 ⁵ / ₈ (828.7)	23 (584)	3 (76.0)	
	240	2.0	1	1	CBES25G6S	C1-17	C1-13	29 (14)	32 ⁵ / ₈ (828.7)	23 (584)	3 (76.0)	
1 1/4 inch NPT Screw Plug (FIREBAR)												
30 W/in² Steel Tank 1-Alloy 800 Element (4.7 W/cm²)	240	1.7	3	1	CBDNF16G12S	C2-50	C2-92	26 (12)	24 ⁵ / ₈ (625.5)	15 (381)	3 ¹ / ₈ (79.4)	
	480	1.7	3	1	CBDNF16G13S	C2-43	C2-35	26 (12)	24 ⁵ / ₈ (625.5)	15 (381)	3 ¹ / ₈ (79.4)	
	240	2.2	3	1	CBDNF19G12S	C2-50	C2-92	30 (14)	32 ⁵ / ₈ (828.7)	23 (584)	3 ¹ / ₈ (79.4)	
	480	2.2	3	1	CBDNF19G13S	C2-43	C2-35	30 (14)	32 ⁵ / ₈ (828.7)	23 (584)	3 ¹ / ₈ (79.4)	
	240	2.8	3	1	CBDNF24L12S	C2-50	C2-92	31 (14)	32 ⁵ / ₈ (828.7)	23 (584)	3 ¹ / ₈ (79.4)	
	480	2.8	3	1	CBDNF24L13S	C2-43	C2-35	31 (14)	32 ⁵ / ₈ (828.7)	23 (584)	3 ¹ / ₈ (79.4)	
	240	3.5	3	1	CBDNF29R12S	C2-50	C2-92	43 (20)	42 ⁵ / ₈ (1082.7)	32 (813)	4 ³ / ₈ (111.1)	
	480	3.5	3	1	CBDNF29R13S	C2-43	C2-35	43 (20)	42 ⁵ / ₈ (1082.7)	32 (813)	4 ³ / ₈ (111.1)	
	240	4.3	3	1	CBDNF34R12S	C2-50	C2-92	44 (20)	42 ⁵ / ₈ (1082.7)	32 (813)	4 ³ / ₈ (111.1)	
	480	4.3	3	1	CBDNF34R13S	C2-43	C2-35	44 (20)	42 ⁵ / ₈ (1082.7)	32 (813)	4 ³ / ₈ (111.1)	
	240	5.7	3	1	CBDNF45G12S	C2-50	C2-92	69 (32)	63 ⁵ / ₈ (1616.1)	53 (1346)	4 ³ / ₈ (111.1)	
	480	5.7	3	1	CBDNF45G13S	C2-43	C2-35	69 (32)	63 ⁵ / ₈ (1616.1)	53 (1346)	4 ³ / ₈ (111.1)	
	240	7.2	3	1	CBDNF55R12S	C2-50	C2-92	71 (33)	63 ⁵ / ₈ (1616.1)	53 (1346)	4 ³ / ₈ (111.1)	
	480	7.2	3	1	CBDNF55R13S	C2-43	C2-35	71 (33)	63 ⁵ / ₈ (1616.1)	53 (1346)	4 ³ / ₈ (111.1)	
	1 1/4 inch NPT Screw Plug (FIREBAR)											
	23 W/in² Steel Tank 1-Alloy 800 Element (3.6 W/cm²)	240	1.25	3	1	CBDNF16G20S	C2-50	C2-92	26 (12)	24 ⁵ / ₈ (625.5)	15 (381)	3 ¹ / ₈ (79.4)
240		1.65	3	1	CBDNF19G20S	C2-50	C2-92	30 (14)	32 ⁵ / ₈ (828.7)	23 (584)	3 ¹ / ₈ (79.4)	
240		2.15	3	1	CBDNF24L20S	C2-50	C2-92	31 (14)	32 ⁵ / ₈ (828.7)	23 (584)	3 ¹ / ₈ (79.4)	
480		2.15	3	1	CBDNF24L19S	C2-43	C2-35	31 (14)	32 ⁵ / ₈ (828.7)	23 (584)	3 ¹ / ₈ (79.4)	
240		2.65	3	1	CBDNF29R20S	C2-50	C2-92	43 (20)	42 ⁵ / ₈ (1082.7)	32 (813)	4 ³ / ₈ (111.1)	
480		2.65	3	1	CBDNF29R19S	C2-43	C2-35	43 (20)	42 ⁵ / ₈ (1082.7)	32 (813)	4 ³ / ₈ (111.1)	
240		3.20	3	1	CBDNF34R20S	C2-50	C2-92	44 (20)	42 ⁵ / ₈ (1082.7)	32 (813)	4 ³ / ₈ (111.1)	
480		3.20	3	1	CBDNF34R19S	C2-43	C2-35	44 (20)	42 ⁵ / ₈ (1082.7)	32 (813)	4 ³ / ₈ (111.1)	
240		4.25	3	1	CBDNF45G20S	C2-50	C2-92	69 (32)	63 ⁵ / ₈ (1616.1)	53 (1346)	4 ³ / ₈ (111.1)	
480		4.25	3	1	CBDNF45G19S	C2-43	C2-35	69 (32)	63 ⁵ / ₈ (1616.1)	53 (1346)	4 ³ / ₈ (111.1)	
240		5.40	3	1	CBDNF55R20S	C2-50	C2-92	71 (33)	63 ⁵ / ₈ (1616.1)	53 (1346)	4 ³ / ₈ (111.1)	
480		5.40	3	1	CBDNF55R19S	C2-43	C2-35	71 (33)	63 ⁵ / ₈ (1616.1)	53 (1346)	4 ³ / ₈ (111.1)	

1 1/4 inch NPT Screw Plug

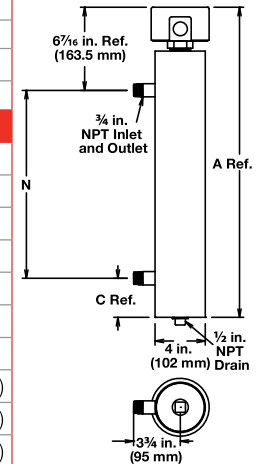

④ Wired for higher voltage



Circulation Heaters

WATROD and FIREBAR Circulation Heaters

Application: Lightweight Oils and Heat Transfer Oils

- WATROD or FIREBAR elements
- Without thermostat
- General purpose enclosure

Description	Volts	kW	Ph	# Circ.	Part Number	WATCONNECT Part Number		Ship Wt. lbs (kg)	"A" Dim. in. (mm)	"N" Dim. in. (mm)	"C" Dim. in. (mm)
						Type J T/C	Type K T/C				
2 1/2 inch NPT Screw Plug (WATROD)											
23 W/in² Steel Tank 3-Steel (3.6 W/cm²)	240	3.0	3	1	CBLS717E3S	C2-50	C2-92	24 (11)	34 ³ / ₄ (881)	22 ¹ / ₂ (572)	16 ¹ / ₂ (419)
	480	3.0	3	1	CBLS717E5S	C2-43	C2-35	24 (11)	34 ³ / ₄ (881)	22 ¹ / ₂ (572)	16 ¹ / ₂ (419)
	240	4.5	3	1	CBLS724N3S	C2-50	C2-92	27 (13)	34 ³ / ₄ (881)	22 ¹ / ₂ (572)	16 ¹ / ₂ (419)
	480	4.5	3	1	CBLS724N5S	C2-43	C2-35	27 (13)	34 ³ / ₄ (881)	22 ¹ / ₂ (572)	16 ¹ / ₂ (419)
	240	6.0	3	1	CBLS732E3S	C2-50	C2-92	29 (14)	44 ³ / ₄ (1135)	32 ¹ / ₂ (826)	26 ¹ / ₂ (673)
	480	6.0	3	1	CBLS732E5S	C2-43	C2-35	29 (14)	44 ³ / ₄ (1135)	32 ¹ / ₂ (826)	26 ¹ / ₂ (673)
	240	7.5	3	1	CBLS739N3S	C2-50	C2-92	31 (14)	57 ¹ / ₄ (1453)	45 (1143)	39 (991)
	480	7.5	3	1	CBLS739N5S	C2-43	C2-35	31 (14)	57 ¹ / ₄ (1453)	45 (1143)	39 (991)
	240	9.0	3	1	CBLS747E3S	C2-50	C2-92	32 (15)	57 ¹ / ₄ (1453)	45 (1143)	39 (991)
480	9.0	3	1	CBLS747E5S	C2-43	C2-35	32 (15)	57 ¹ / ₄ (1453)	45 (1143)	39 (991)	
2 1/2 inch NPT Screw Plug (FIREBAR)											
30 W/in² Steel Tank 3-Alloy 800 Elements (4.7 W/cm²)	240	5.0	3	1	CBLNF15C12S	C2-50	C2-92	22 (10)	34 ³ / ₄ (881)	22 ¹ / ₂ (572)	16 ¹ / ₂ (419)
	480	5.0	3	1	CBLNF15C13S	C2-43	C2-35	22 (10)	34 ³ / ₄ (881)	22 ¹ / ₂ (572)	16 ¹ / ₂ (419)
	240	6.5	3	1	CBLNF18C12S	C2-50	C2-92	23 (11)	34 ³ / ₄ (881)	22 ¹ / ₂ (572)	16 ¹ / ₂ (419)
	480	6.5	3	1	CBLNF18C13S	C2-43	C2-35	23 (11)	34 ³ / ₄ (881)	22 ¹ / ₂ (572)	16 ¹ / ₂ (419)
	240	8.5	3	1	CBLNF23C12S	C2-50	C2-92	31 (14)	34 ³ / ₄ (881)	22 ¹ / ₂ (572)	16 ¹ / ₂ (419)
	480	8.5	3	1	CBLNF23C13S	C2-43	C2-35	31 (14)	34 ³ / ₄ (881)	22 ¹ / ₂ (572)	16 ¹ / ₂ (419)
	240	10.5	3	1	CBLNF28L12S	C2-236	C2-214	34 (16)	44 ³ / ₄ (1135)	32 ¹ / ₂ (826)	26 ¹ / ₂ (673)
	480	10.5	3	1	CBLNF28L13S	C2-43	C2-35	34 (16)	44 ³ / ₄ (1135)	32 ¹ / ₂ (826)	26 ¹ / ₂ (673)
	240	12.8	3	1	CBLNF33L12S	C2-236	C2-214	35 (16)	44 ³ / ₄ (1135)	32 ¹ / ₂ (826)	26 ¹ / ₂ (673)
	480	12.8	3	1	CBLNF33L13S	C2-43	C2-35	35 (16)	44 ³ / ₄ (1135)	32 ¹ / ₂ (826)	26 ¹ / ₂ (673)
	240	17.0	3	1	CBLNF44C12S	C2-236	C2-214	44 (20)	57 ¹ / ₄ (1453)	45 (1143)	39 (991)
	480	17.0	3	1	CBLNF44C13S	C2-43	C2-35	44 (20)	57 ¹ / ₄ (1453)	45 (1143)	39 (991)
	480	21.5	3	1	CBLNF54L13S	C2-225	C2-226	52 (24)	63 ³ / ₄ (1618)	51 ¹ / ₂ (1308)	46 ¹ / ₂ (1181)
	2 1/2 inch NPT Screw Plug (FIREBAR)										
23 W/in² Steel Tank 3-Alloy 800 Elements (3.6 W/cm²)	240	3.80	3	1	CBLNF15C20S	C2-50	C2-92	22 (10)	34 ³ / ₄ (881)	22 ¹ / ₂ (572)	16 ¹ / ₂ (419)
	240	4.90	3	1	CBLNF18C20S	C2-50	C2-92	23 (11)	34 ³ / ₄ (881)	22 ¹ / ₂ (572)	16 ¹ / ₂ (419)
	240	6.40	3	1	CBLNF23C20S	C2-50	C2-92	31 (14)	34 ³ / ₄ (881)	22 ¹ / ₂ (572)	16 ¹ / ₂ (419)
	480	6.40	3	1	CBLNF23C19S	C2-43	C2-35	31 (14)	34 ³ / ₄ (881)	22 ¹ / ₂ (572)	16 ¹ / ₂ (419)
	240	7.90	3	1	CBLNF28L20S	C2-50	C2-92	34 (16)	44 ³ / ₄ (1135)	32 ¹ / ₂ (826)	26 ¹ / ₂ (673)
	480	7.90	3	1	CBLNF28L19S	C2-43	C2-35	34 (16)	44 ³ / ₄ (1135)	32 ¹ / ₂ (826)	26 ¹ / ₂ (673)
	240	9.60	3	1	CBLNF33L20S	C2-50	C2-92	35 (16)	44 ³ / ₄ (1135)	32 ¹ / ₂ (826)	26 ¹ / ₂ (673)
	480	9.60	3	1	CBLNF33L19S	C2-43	C2-35	35 (16)	44 ³ / ₄ (1135)	32 ¹ / ₂ (826)	26 ¹ / ₂ (673)
	240	12.80	3	1	CBLNF44C20S	C2-236	C2-214	44 (20)	57 ¹ / ₄ (1453)	45 (1143)	39 (991)
	480	12.80	3	1	CBLNF44C19S	C2-43	C2-35	44 (20)	57 ¹ / ₄ (1453)	45 (1143)	39 (991)
	240	16.10	3	1	CBLNF54L20S	C2-236	C2-214	52 (24)	63 ³ / ₄ (1618)	51 ¹ / ₂ (1308)	46 ¹ / ₂ (1181)
480	16.10	3	1	CBLNF54L19S	C2-43	C2-35	52 (24)	63 ³ / ₄ (1618)	51 ¹ / ₂ (1308)	46 ¹ / ₂ (1181)	

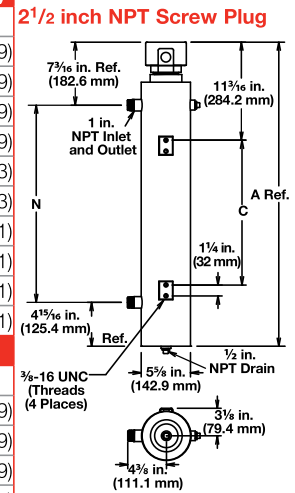

③ Wired for 3-phase operation only
 ⑧ Can be wired for 1-phase operation



Circulation Heaters

WATROD and FIREBAR Circulation Heaters



Application: Lightweight Oils and Heat Transfer Oils

- WATROD elements
- Without thermostat
- General purpose enclosure

Description	Volts	kW	Ph	# Circ.	Part Number	WATCONNECT Part Number		Ship Wt. lbs (kg)	"A" Dim. in. (mm)	"N" Dim. in. (mm)	"C" Dim. in. (mm)
						Type J T/C	Type K T/C				
3 inch - 150 lb ANSI Flange (WATROD)											
23 W/in² Steel Tank 3-Steel Elements (3.6 W/cm²)	240	3.0	1	1	CFMS718A10S	C1-17	C1-13	68 (31)	35 ¹ / ₄ (894)	22 ¹ / ₂ (573)	16 ¹ / ₂ (419)
	240	3.0	3	1	CFMS718A3S	C2-50	C2-92	68 (31)	35 ¹ / ₄ (894)	22 ¹ / ₂ (573)	16 ¹ / ₂ (419)
	480	3.0	1	1	CFMS718A11S	C/F	C/F	68 (31)	35 ¹ / ₄ (894)	22 ¹ / ₂ (573)	16 ¹ / ₂ (419)
	480	3.0	3	1	CFMS718A5S	C2-43	C2-35	68 (31)	35 ¹ / ₄ (894)	22 ¹ / ₂ (573)	16 ¹ / ₂ (419)
	240	4.5	1	1	CFMS725J10S	C/F	C/F	78 (36)	35 ¹ / ₄ (894)	22 ¹ / ₂ (573)	16 ¹ / ₂ (419)
	240	4.5	3	1	CFMS725J3S	C2-50	C2-92	78 (36)	35 ¹ / ₄ (894)	22 ¹ / ₂ (573)	16 ¹ / ₂ (419)
	480	4.5	1	1	CFMS725J11S	C/F	C/F	78 (36)	35 ¹ / ₄ (894)	22 ¹ / ₂ (573)	16 ¹ / ₂ (419)
	480	4.5	3	1	CFMS725J5S	C2-43	C2-35	78 (36)	35 ¹ / ₄ (894)	22 ¹ / ₂ (573)	16 ¹ / ₂ (419)
	240	6.0	1	2	CFMS733A10S	C/F	C/F	96 (44)	45 ¹ / ₄ (1148)	32 ¹ / ₂ (826)	26 ¹ / ₂ (673)
	240	6.0	3	1	CFMS733A3S	C2-50	C2-92	96 (44)	45 ¹ / ₄ (1148)	32 ¹ / ₂ (826)	26 ¹ / ₂ (673)
	480	6.0	1	1	CFMS733A11S	C/F	C/F	96 (44)	45 ¹ / ₄ (1148)	32 ¹ / ₂ (826)	26 ¹ / ₂ (673)
	480	6.0	3	1	CFMS733A5S	C2-43	C2-35	96 (44)	45 ¹ / ₄ (1148)	32 ¹ / ₂ (826)	26 ¹ / ₂ (673)
	240	7.5	1	2	CFMS740J10S	C/F	C/F	100 (46)	57 ³ / ₄ (1465)	45 (1143)	39 (991)
	240	7.5	3	1	CFMS740J3S	C2-50	C2-92	100 (46)	57 ³ / ₄ (1465)	45 (1143)	39 (991)
	480	7.5	1	1	CFMS740J11S	C/F	C/F	100 (46)	57 ³ / ₄ (1465)	45 (1143)	39 (991)
	480	7.5	3	1	CFMS740J5S	C2-43	C2-35	100 (46)	57 ³ / ₄ (1465)	45 (1143)	39 (991)
	240	9.0	1	2	CFMS748A10S	C/F	C/F	107 (49)	57 ³ / ₄ (1465)	45 (1143)	39 (991)
	240	9.0	3	1	CFMS748A3S	C2-50	C2-92	107 (49)	57 ³ / ₄ (1465)	45 (1143)	39 (991)
	480	9.0	1	1	CFMS748A11S	C/F	C/F	107 (49)	57 ³ / ₄ (1465)	45 (1143)	39 (991)
	480	9.0	3	1	CFMS748A5S	C2-43	C2-35	107 (49)	57 ³ / ₄ (1465)	45 (1143)	39 (991)
4 inch - 150 lb ANSI Flange (WATROD)											
23 W/in² Steel Tank 6-Steel Elements (3.6 W/cm²)	240	6.0	1	1	CFOS718A10S	C/F	C/F	125 (57)	39 (989)	20 ¹ / ₂ (521)	17 (432)
	240	6.0	3	1	CFOS718A3S	C2-50	C2-92	125 (57)	39 (989)	20 ¹ / ₂ (521)	17 (432)
	480	6.0	1	1	CFOS718A11S	C/F	C/F	125 (57)	39 (989)	20 ¹ / ₂ (521)	17 (432)
	480	6.0	3	1	CFOS718A5S	C2-43	C2-35	125 (57)	39 (989)	20 ¹ / ₂ (521)	17 (432)
	240	9.0	1	1	CFOS725J10S	C/F	C/F	160 (73)	39 (989)	20 ¹ / ₂ (521)	17 (432)
	240	9.0	3	1	CFOS725J3S	C2-50	C2-92	160 (73)	39 (989)	20 ¹ / ₂ (521)	17 (432)
	480	9.0	1	1	CFOS725J11S	C/F	C/F	160 (73)	39 (989)	20 ¹ / ₂ (521)	17 (432)
	480	9.0	3	1	CFOS725J5S	C2-43	C2-35	160 (73)	39 (989)	20 ¹ / ₂ (521)	17 (432)
	240	12.0	1	2	CFOS733A10S	C/F	C/F	163 (74)	49 ¹ / ₂ (1256)	31 (787)	27 ¹ / ₂ (699)
	240	12.0	3	1	CFOS733A3S	C2-236	C2-214	163 (74)	49 ¹ / ₂ (1256)	31 (787)	27 ¹ / ₂ (699)
	480	12.0	1	1	CFOS733A11S	C/F	C/F	163 (74)	49 ¹ / ₂ (1256)	31 (787)	27 ¹ / ₂ (699)
	480	12.0	3	1	CFOS733A5S	C2-43	C2-35	163 (74)	49 ¹ / ₂ (1256)	31 (787)	27 ¹ / ₂ (699)
	240	15.0	1	2	CFOS740J10S	C/F	C/F	229(104)	70 ¹ / ₂ (1789)	52 (1321)	48 ¹ / ₂ (1232)
	240	15.0	3	1	CFOS740J3S	C2-236	C2-214	229(104)	70 ¹ / ₂ (1789)	52 (1321)	48 ¹ / ₂ (1232)
	480	15.0	1	1	CFOS740J11S	C/F	C/F	229(104)	70 ¹ / ₂ (1789)	52 (1321)	48 ¹ / ₂ (1232)
	480	15.0	3	1	CFOS740J5S	C2-43	C2-35	229(104)	70 ¹ / ₂ (1789)	52 (1321)	48 ¹ / ₂ (1232)
	240	18.0	1	2	CFOS748A10S	C/F	C/F	234(107)	70 ¹ / ₂ (1789)	52 (1321)	48 ¹ / ₂ (1232)
	240	18.0	3	1	CFOS748A3S	C2-236	C2-214	234(107)	70 ¹ / ₂ (1789)	52 (1321)	48 ¹ / ₂ (1232)
	480	18.0	1	1	CFOS748A11S	C/F	C/F	234(107)	70 ¹ / ₂ (1789)	52 (1321)	48 ¹ / ₂ (1232)
	480	18.0	3	1	CFOS748A5S	C2-43	C2-35	234(107)	70 ¹ / ₂ (1789)	52 (1321)	48 ¹ / ₂ (1232)
	240	25.0	3	2	CFOS764J3S	C2-218	C2-224	298(136)	91 ¹ / ₂ (2326)	73 (1854)	66 (1676)
	480	25.0	1	2	CFOS764J11S	C/F	C/F	298(136)	91 ¹ / ₂ (2326)	73 (1854)	66 (1676)
	480	25.0	3	1	CFOS764J5S	C2-225	C2-226	298(136)	91 ¹ / ₂ (2326)	73 (1854)	66 (1676)
	240	30.0	3	2	CFOS777A3S	C2-218	C2-224	306(139)	91 ¹ / ₂ (2326)	73 (1854)	66 (1676)
	480	30.0	1	2	CFOS777A11S	C/F	C/F	306(139)	91 ¹ / ₂ (2326)	73 (1854)	66 (1676)
	480	30.0	3	1	CFOS777A5S	C2-225	C2-226	306(139)	91 ¹ / ₂ (2326)	73 (1854)	66 (1676)

3 inch - 150 lb ANSI Flange

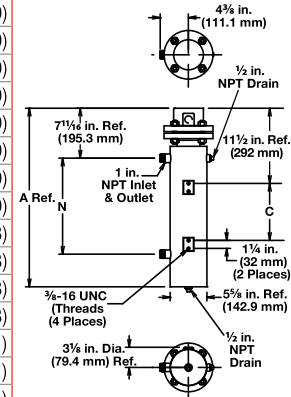

4 inch - 150 lb ANSI Flange

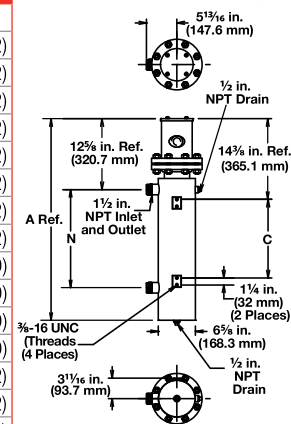

C/F - Contact factory, go to www.watlow.com/en/contact-us



Circulation Heaters



WATROD and FIREBAR Circulation Heaters



Application: Lightweight Oils and Heat Transfer Oils

- WATROD elements
- Without thermostat
- General purpose enclosure

Description	Volts	kW	Ph	# Circ.	Part Number	WATCONNECT Part Number		Ship Wt. lbs (kg)	"A" Dim. in. (mm)	"N" Dim. in. (mm)	"C" Dim. in. (mm)
						Type J T/C	Type K T/C				
5 inch - 150 lb ANSI Flange (WATROD)											
23 W/in² Steel Tank 6-Steel Elements (3.6 W/cm²)	240	12.0	1	2	CFNS733A10S	C/F	C/F	145 (66)	56 ¹ / ₄ (1427.0)	37 (940.0)	18 ⁵ / ₈ (473.1)
	240	12.0	3	1	CFNS733A3S	C2-236	C2-214	145 (66)	56 ¹ / ₄ (1427.0)	37 (940.0)	18 ⁵ / ₈ (473.1)
	480	12.0	1	1	CFNS733A11S	C/F	C/F	145 (66)	56 ¹ / ₄ (1427.0)	37 (940.0)	18 ⁵ / ₈ (473.1)
	480	12.0	3	1	CFNS733A5S	C2-43	C2-35	145 (66)	56 ¹ / ₄ (1427.0)	37 (940.0)	18 ⁵ / ₈ (473.1)
	240	15.0	1	2	CFNS740J10S	C/F	C/F	167 (76)	56 ¹ / ₄ (1427.0)	37 (940.0)	18 ⁵ / ₈ (473.1)
	240	15.0	3	1	CFNS740J3S	C2-236	C2-214	167 (76)	56 ¹ / ₄ (1427.0)	37 (940.0)	18 ⁵ / ₈ (473.1)
	480	15.0	1	1	CFNS740J11S	C/F	C/F	167 (76)	56 ¹ / ₄ (1427.0)	37 (940.0)	18 ⁵ / ₈ (473.1)
	480	15.0	3	1	CFNS740J5S	C2-43	C2-35	167 (76)	56 ¹ / ₄ (1427.0)	37 (940.0)	18 ⁵ / ₈ (473.1)
	240	18.0	1	2	CFNS748A10S	C/F	C/F	180 (82)	67 ³ / ₄ (1719.0)	48 ¹ / ₂ (1232.0)	18 ⁵ / ₈ (473.1)
	240	18.0	3	1	CFNS748A3S	C2-236	C2-214	180 (82)	67 ³ / ₄ (1719.0)	48 ¹ / ₂ (1232.0)	18 ⁵ / ₈ (473.1)
	480	18.0	1	1	CFNS748A11S	C/F	C/F	180 (82)	67 ³ / ₄ (1719.0)	48 ¹ / ₂ (1232.0)	18 ⁵ / ₈ (473.1)
	480	18.0	3	1	CFNS748A5S	C2-43	C2-35	180 (82)	67 ³ / ₄ (1719.0)	48 ¹ / ₂ (1232.0)	18 ⁵ / ₈ (473.1)
	240	25.0	3	2	CFNS764J3S	C2-218	C2-224	195 (89)	81 ¹ / ₈ (2060.6)	61 ⁷ / ₈ (1571.6)	25 (633.0)
	480	25.0	1	2	CFNS764J11S	C/F	C/F	195 (89)	81 ¹ / ₈ (2060.6)	61 ⁷ / ₈ (1571.6)	25 (633.0)
	480	25.0	3	1	CFNS764J5S	C2-225	C2-226	195 (89)	81 ¹ / ₈ (2060.6)	61 ⁷ / ₈ (1571.6)	25 (633.0)
	240	30.0	3	2	CFNS777A3S	C2-218	C2-224	220 (100)	94 ¹ / ₈ (2390.8)	75 (1902.0)	25 (633.0)
480	30.0	1	2	CFNS777A11S	C/F	C/F	220 (100)	94 ¹ / ₈ (2390.8)	75 (1902.0)	25 (633.0)	
480	30.0	3	1	CFNS777A5S	C2-225	C2-226	220 (100)	94 ¹ / ₈ (2390.8)	75 (1902.0)	25 (633.0)	

C/F - Contact factory, go to www.watlow.com/en/contact-us

5 inch - 150 lb ANSI Flange

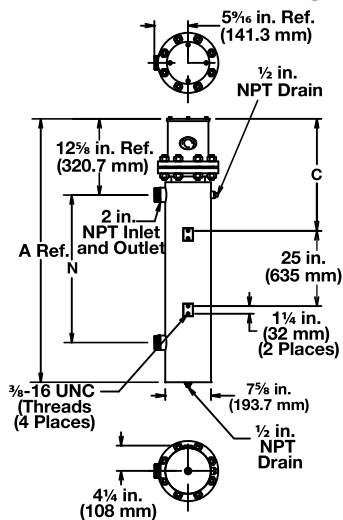



Circulation Heaters

WATROD and FIREBAR Circulation Heaters



Application: Lightweight Oils and Heat Transfer Oils

- WATROD elements
- Without thermostat
- General purpose enclosure

Description	Volts	kW	Ph	# Circ.	Part Number	WATCONNECT Part Number		Ship Wt. lbs (kg)	"A" Dim. in. (mm)	"N" Dim. in. (mm)	"C" Dim. in. (mm)
						Type J T/C	Type K T/C				
5 inch - 150 lb ANSI Flange (WATROD)											
23 W/in² Steel Tank 9-Steel Elements (3.6 W/cm²)	240	18.0	1	3	CFNS733A10XS	C/F	C/F	150 (68)	56 ¹ / ₄ (1427.0)	37 (940.0)	18 ⁵ / ₈ (471.1)
	240	18.0	3	1	CFNS733A3XS	C2-236	C2-214	150 (68)	56 ¹ / ₄ (1427.0)	37 (940.0)	18 ⁵ / ₈ (471.1)
	480	18.0	1	1	CFNS733A11XS	C/F	C/F	150 (68)	56 ¹ / ₄ (1427.0)	37 (940.0)	18 ⁵ / ₈ (471.1)
	480	18.0	3	1	CFNS733A5XS	C2-43	C2-35	150 (68)	56 ¹ / ₄ (1427.0)	37 (940.0)	18 ⁵ / ₈ (471.1)
	240	23.0	1	3	CFNS740J10XS	C/F	C/F	173 (79)	56 ¹ / ₄ (1427.0)	37 (940.0)	18 ⁵ / ₈ (471.1)
	240	23.0	3	3	CFNS740J3XS	C4-143	C4-142	173 (79)	56 ¹ / ₄ (1427.0)	37 (940.0)	18 ⁵ / ₈ (471.1)
	480	23.0	1	1	CFNS740J11XS	C/F	C/F	173 (79)	56 ¹ / ₄ (1427.0)	37 (940.0)	18 ⁵ / ₈ (471.1)
	480	23.0	3	1	CFNS740J5XS	C2-225	C2-226	173 (79)	56 ¹ / ₄ (1427.0)	37 (940.0)	18 ⁵ / ₈ (471.1)
	240	27.0	1	3	CFNS748A10XS	C/F	C/F	188 (86)	67 ³ / ₄ (1719.0)	48 ¹ / ₂ (1232.0)	25 (633.0)
	240	27.0	3	3	CFNS748A3XS	C4-143	C4-142	188 (86)	67 ³ / ₄ (1719.0)	48 ¹ / ₂ (1232.0)	25 (633.0)
	480	27.0	1	3	CFNS748A11XS	C/F	C/F	188 (86)	67 ³ / ₄ (1719.0)	48 ¹ / ₂ (1232.0)	25 (633.0)
	480	27.0	3	1	CFNS748A5XS	C2-225	C2-226	188 (86)	67 ³ / ₄ (1719.0)	48 ¹ / ₂ (1232.0)	25 (633.0)
	240	38.0	3	3	CFNS764J3XS	C4-144	C4-145	206 (94)	81 ¹ / ₈ (2060.6)	61 ⁷ / ₈ (1571.6)	25 (633.0)
	480	38.0	1	3	CFNS764J11XS	C/F	C/F	206 (94)	81 ¹ / ₈ (2060.6)	61 ⁷ / ₈ (1571.6)	25 (633.0)
	480	38.0	3	1	CFNS764J5XS	C2-225	C2-226	206 (94)	81 ¹ / ₈ (2060.6)	61 ⁷ / ₈ (1571.6)	25 (633.0)
	240	45.0	3	3	CFNS777A3XS	C4-144	C4-145	233 (106)	94 ¹ / ₈ (2390.8)	75 (1902.0)	25 (633.0)
480	45.0	1	3	CFNS777A11XS	C/F	C/F	233 (106)	94 ¹ / ₈ (2390.8)	75 (1902.0)	25 (633.0)	
480	45.0	3	3	CFNS777A5XS	C4-150	C4-151	233 (106)	94 ¹ / ₈ (2390.8)	75 (1902.0)	25 (633.0)	

C/F - Contact factory, go to www.watlow.com/en/contact-us

5 inch - 150 lb ANSI Flange

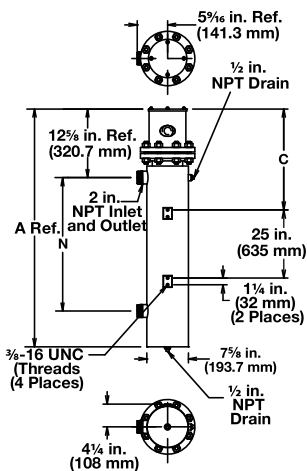



Circulation Heaters

WATROD and FIREBAR Circulation Heaters

Application: Lightweight Oils and Heat Transfer Oils

- WATROD elements
- Without thermostat
- General purpose enclosure

Description	Volts	kW	Ph	# Circ.	Part Number	WATCONNECT Part Number		Ship Wt. lbs (kg)	"A" Dim. in. (mm)	"N" Dim. in. (mm)	"C" Dim. in. (mm)
						Type J T/C	Type K T/C				
6 inch - 150 lb ANSI Flange (WATROD)											
23 W/in² Steel Tank 12-Steel Elements (3.6 W/cm²)	240	12.0	1	2	CFPS717R10S	C/F	C/F	214 (97)	40 ¹ / ₂ (1027)	20 ¹ / ₂ (521)	17 (432)
	240	12.0	3	1	CFPS717R3S	C2-236	C2-214	214 (97)	40 ¹ / ₂ (1027)	20 ¹ / ₂ (521)	17 (432)
	480	12.0	1	1	CFPS717R11S	C/F	C/F	214 (97)	40 ¹ / ₂ (1027)	20 ¹ / ₂ (521)	17 (432)
	480	12.0	3	1	CFPS717R5S	C2-43	C2-35	214 (97)	40 ¹ / ₂ (1027)	20 ¹ / ₂ (521)	17 (432)
	240	18.0	1	2	CFPS725G10S	C/F	C/F	222 (101)	40 ¹ / ₂ (1027)	20 ¹ / ₂ (521)	17 (432)
	240	18.0	3	1	CFPS725G3S	C2-236	C2-214	222 (101)	40 ¹ / ₂ (1027)	20 ¹ / ₂ (521)	17 (432)
	480	18.0	1	1	CFPS725G11S	C/F	C/F	222 (101)	40 ¹ / ₂ (1027)	20 ¹ / ₂ (521)	17 (432)
	480	18.0	3	1	CFPS725G5S	C2-43	C2-35	222 (101)	40 ¹ / ₂ (1027)	20 ¹ / ₂ (521)	17 (432)
	240	24.0	1	3	CFPS732R10S	C/F	C/F	226 (103)	51 (1294)	31 (787)	27 ¹ / ₂ (699)
	240	24.0	3	2	CFPS732R3S	C2-218	C2-224	226 (103)	51 (1294)	31 (787)	27 ¹ / ₂ (699)
	480	24.0	1	2	CFPS732R11S	C/F	C/F	226 (103)	51 (1294)	31 (787)	27 ¹ / ₂ (699)
	480	24.0	3	1	CFPS732R5S	C2-225	C2-226	226 (103)	51 (1294)	31 (787)	27 ¹ / ₂ (699)
	240	30.0	1	3	CFPS740G10S	C/F	C/F	290 (132)	72 (1827)	52 (1321)	48 ¹ / ₂ (1232)
	240	30.0	3	2	CFPS740G3S	C2-218	C2-224	290 (132)	72 (1827)	52 (1321)	48 ¹ / ₂ (1232)
	480	30.0	1	2	CFPS740G11S	C/F	C/F	290 (132)	72 (1827)	52 (1321)	48 ¹ / ₂ (1232)
	480	30.0	3	1	CFPS740G5S	C2-225	C2-226	290 (132)	72 (1827)	52 (1321)	48 ¹ / ₂ (1232)
	240	36.0	1	4	CFPS747R10S	C/F	C/F	298 (136)	72 (1827)	52 (1321)	48 ¹ / ₂ (1232)
	240	36.0	3	2	CFPS747R3S	C2-218	C2-224	298 (136)	72 (1827)	52 (1321)	48 ¹ / ₂ (1232)
	480	36.0	1	2	CFPS747R11S	C/F	C/F	298 (136)	72 (1827)	52 (1321)	48 ¹ / ₂ (1232)
	480	36.0	3	1	CFPS747R5S	C2-225	C2-226	298 (136)	72 (1827)	52 (1321)	48 ¹ / ₂ (1232)
	240	50.0	3	4	CFPS764G3S	C4-148	C4-149	360 (164)	93 (2361)	73 (1854)	66 (1676)
	480	50.0	1	3	CFPS764G11S	C/F	C/F	360 (164)	93 (2361)	73 (1854)	66 (1676)
	480	50.0	3	2	CFPS764G5S	C2-225	C2-226	360 (164)	93 (2361)	73 (1854)	66 (1676)
	240	60.0	3	4	CFPS776R3S	C4-148	C4-149	368 (167)	93 (2361)	73 (1854)	66 (1676)
480	60.0	1	3	CFPS776R11S	C/F	C/F	368 (167)	93 (2361)	73 (1854)	66 (1676)	
480	60.0	3	2	CFPS776R5S	C2-225	C2-226	368 (167)	93 (2361)	73 (1854)	66 (1676)	

C/F - Contact factory, go to www.watlow.com/en/contact-us

6 inch - 150 lb ANSI Flange

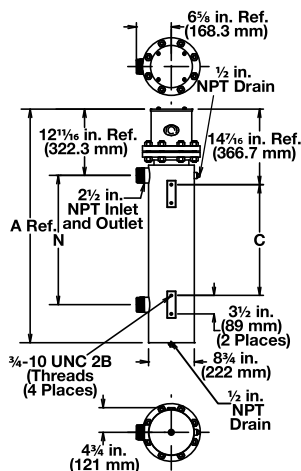

Circulation Heaters



WATROD and FIREBAR Circulation Heaters



Application: Lightweight Oils and Heat Transfer Oils

- WATROD elements
- Without thermostat
- General purpose enclosure

Description	Volts	kW	Ph	# Circ.	Part Number	WATCONNECT Part Number		Ship Wt. lbs (kg)	"A" Dim. in. (mm)		"N" Dim. in. (mm)		"C" Dim. in. (mm)	
						Type J T/C	Type K T/C							
6 inch - 150 lb ANSI Flange (WATROD)														
23 W/in² Steel Tank 15-Steel Elements (3.6 W/cm²)	240	15.0	1	3	CFPS717R10XS	C/F	C/F	217 (99)	40 ¹ / ₂ (1027)	20 ¹ / ₂ (521)	17	(432)		
	240	15.0	3	1	CFPS717R3XS	C2-236	C2-214	217 (99)	40 ¹ / ₂ (1027)	20 ¹ / ₂ (521)	17	(432)		
	480	15.0	1	1	CFPS717R11XS	C/F	C/F	217 (99)	40 ¹ / ₂ (1027)	20 ¹ / ₂ (521)	17	(432)		
	480	15.0	3	1	CFPS717R5XS	C2-43	C2-35	217 (99)	40 ¹ / ₂ (1027)	20 ¹ / ₂ (521)	17	(432)		
	240	23.0	1	3	CFPS725G10XS	C/F	C/F	222 (101)	40 ¹ / ₂ (1027)	20 ¹ / ₂ (521)	17	(432)		
	240	23.0	3	5	CFPS725G3XS	C4-143	C4-142	222 (101)	40 ¹ / ₂ (1027)	20 ¹ / ₂ (521)	17	(432)		
	480	23.0	1	1	CFPS725G11XS	C/F	C/F	222 (101)	40 ¹ / ₂ (1027)	20 ¹ / ₂ (521)	17	(432)		
	480	23.0	3	1	CFPS725G5XS	C2-225	C2-226	222 (101)	40 ¹ / ₂ (1027)	20 ¹ / ₂ (521)	17	(432)		
	240	30.0	1	3	CFPS732R10XS	C/F	C/F	226 (103)	51 (1294)	31 (787)	27 ¹ / ₂	(699)		
	240	30.0	3	5	CFPS732R3XS	C4-144	C4-145	226 (103)	51 (1294)	31 (787)	27 ¹ / ₂	(699)		
	480	30.0	1	3	CFPS732R11XS	C/F	C/F	226 (103)	51 (1294)	31 (787)	27 ¹ / ₂	(699)		
	480	30.0	3	1	CFPS732R5XS	C2-225	C2-226	226 (103)	51 (1294)	31 (787)	27 ¹ / ₂	(699)		
	240	38.0	1	5	CFPS740G10XS	C/F	C/F	290 (132)	72 (1827)	52 (1321)	48 ¹ / ₂	(1232)		
	240	38.0	3	5	CFPS740G3XS	C4-144	C4-145	290 (132)	72 (1827)	52 (1321)	48 ¹ / ₂	(1232)		
	480	38.0	1	3	CFPS740G11XS	C/F	C/F	290 (132)	72 (1827)	52 (1321)	48 ¹ / ₂	(1232)		
	480	38.0	3	1	CFPS740G5XS	C2-225	C2-226	290 (132)	72 (1827)	52 (1321)	48 ¹ / ₂	(1232)		
	240	45.0	1	5	CFPS747R10XS	C/F	C/F	298 (136)	72 (1827)	52 (1321)	48 ¹ / ₂	(1232)		
	240	45.0	3	5	CFPS747R3XS	C4-144	C4-145	298 (136)	72 (1827)	52 (1321)	48 ¹ / ₂	(1232)		
	480	45.0	1	3	CFPS747R11XS	C/F	C/F	298 (136)	72 (1827)	52 (1321)	48 ¹ / ₂	(1232)		
	480	45.0	3	5	CFPS747R5XS	C4-150	C4-151	298 (136)	72 (1827)	52 (1321)	48 ¹ / ₂	(1232)		
240	63.0	3	5	CFPS764G3XS	C/F	C/F	360 (164)	93 (2361)	73 (1854)	66	(1676)			
480	63.0	1	3	CFPS764G11XS	C/F	C/F	360 (164)	93 (2361)	73 (1854)	66	(1676)			
480	63.0	3	5	CFPS764G5XS	C4-152	C4-153	360 (164)	93 (2361)	73 (1854)	66	(1676)			
240	75.0	3	5	CFPS776R3XS	C/F	C/F	368 (167)	93 (2361)	73 (1854)	66	(1676)			
480	75.0	1	5	CFPS776R11XS	C/F	C/F	368 (167)	93 (2361)	73 (1854)	66	(1676)			
480	75.0	3	5	CFPS776R5XS	C4-152	C4-153	368 (167)	93 (2361)	73 (1854)	66	(1676)			

C/F - Contact factory, go to www.watlow.com/en/contact-us

6 inch - 150 lb ANSI Flange

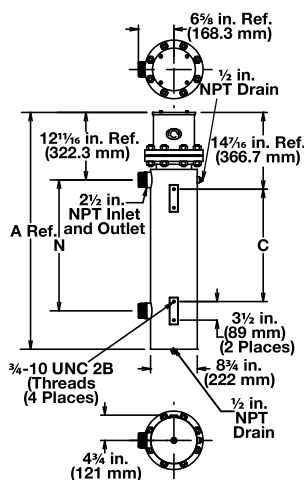

Circulation Heaters



WATROD and FIREBAR Circulation Heaters

Application: Lightweight Oils and Heat Transfer Oils

- WATROD elements
- Without thermostat
- General purpose enclosure

Description	Volts	kW	Ph	# Circ.	Part Number	WATCONNECT Part Number		Ship Wt. lbs (kg)	"A" Dim. in. (mm)	"N" Dim. in. (mm)	"C" Dim. in. (mm)
						Type J T/C	Type K T/C				
8 inch - 150 lb ANSI Flange (WATROD)											
23 W/in² Steel Tank 18-Steel Elements (3.6 W/cm²)	240	30.0	1	3	CFRS732N10S	C/F	C/F	370 (168)	55 ¹ / ₄ (1402.0)	32 ³ / ₄ (830.0)	29 ¹ / ₄ (741.0)
	240	30.0	3	2	CFRS732N3S	C2-218	C2-224	370 (168)	55 ¹ / ₄ (1402.0)	32 ³ / ₄ (830.0)	29 ¹ / ₄ (741.0)
	480	30.0	1	2	CFRS732N11S	C/F	C/F	370 (168)	55 ¹ / ₄ (1402.0)	32 ³ / ₄ (830.0)	29 ¹ / ₄ (741.0)
	480	30.0	3	1	CFRS732N5S	C2-225	C2-226	370 (168)	55 ¹ / ₄ (1402.0)	32 ³ / ₄ (830.0)	29 ¹ / ₄ (741.0)
	240	40.0	3	3	CFRS743E3S	C4-144	C4-145	410 (186)	62 ¹ / ₄ (1580.0)	39 ³ / ₄ (1008.0)	36 ¹ / ₄ (919.0)
	480	40.0	1	2	CFRS743E11S	C/F	C/F	410 (186)	62 ¹ / ₄ (1580.0)	39 ³ / ₄ (1008.0)	36 ¹ / ₄ (919.0)
	480	40.0	3	2	CFRS743E5S	C2-227	C2-228	410 (186)	62 ¹ / ₄ (1580.0)	39 ³ / ₄ (1008.0)	36 ¹ / ₄ (919.0)
	240	50.0	3	3	CFRS751M3S	C4-144	C4-145	440 (200)	69 ⁷ / ₈ (1774.8)	47 ³ / ₈ (1203.3)	43 ⁷ / ₈ (1114.4)
	480	50.0	1	3	CFRS751M11S	C/F	C/F	440 (200)	69 ⁷ / ₈ (1774.8)	47 ³ / ₈ (1203.3)	43 ⁷ / ₈ (1114.4)
	480	50.0	3	2	CFRS751M5S	C2-229	C2-230	440 (200)	69 ⁷ / ₈ (1774.8)	47 ³ / ₈ (1203.3)	43 ⁷ / ₈ (1114.4)
	240	60.0	3	6	CFRS762D3S	C4-144	C4-145	480 (218)	79 ³ / ₈ (2016.1)	56 ⁷ / ₈ (1444.6)	53 ³ / ₈ (1355.7)
	480	60.0	1	3	CFRS762D11S	C/F	C/F	480 (218)	79 ³ / ₈ (2016.1)	56 ⁷ / ₈ (1444.6)	53 ³ / ₈ (1355.7)
	480	60.0	3	2	CFRS762D5S	C2-229	C2-230	480 (218)	79 ³ / ₈ (2016.1)	56 ⁷ / ₈ (1444.6)	53 ³ / ₈ (1355.7)
	240	70.0	3	6	CFRS770M3S	C/F	C/F	530 (241)	88 ³ / ₈ (2244.7)	65 ⁷ / ₈ (1673.2)	62 ³ / ₈ (1584.3)
	480	70.0	1	6	CFRS770M11S	C/F	C/F	530 (241)	88 ³ / ₈ (2244.7)	65 ⁷ / ₈ (1673.2)	62 ³ / ₈ (1584.3)
	480	70.0	3	2	CFRS770M5S	C2-229	C2-230	530 (241)	88 ³ / ₈ (2244.7)	65 ⁷ / ₈ (1673.2)	62 ³ / ₈ (1584.3)
	240	80.0	3	6	CFRS779M3S	C/F	C/F	610 (277)	98 ³ / ₈ (2498.7)	75 ⁷ / ₈ (1927.2)	72 ³ / ₈ (1838.3)
480	80.0	3	3	CFRS779M5S	C4-152	C4-153	610 (277)	98 ³ / ₈ (2498.7)	75 ⁷ / ₈ (1927.2)	72 ³ / ₈ (1838.3)	

C/F - Contact factory, go to www.watlow.com/en/contact-us

8 inch - 150 lb ANSI Flange

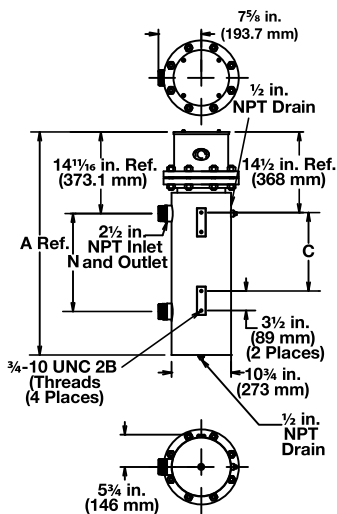

Circulation Heaters



WATROD and FIREBAR Circulation Heaters



Application: Lightweight Oils and Heat Transfer Oils

- WATROD elements
- Without thermostat
- General purpose enclosure

Description	Volts	kW	Ph	# Circ.	Part Number	WATCONNECT Part Number		Ship Wt. lbs (kg)	"A" Dim. in. (mm)	"N" Dim. in. (mm)	"C" Dim. in. (mm)
						Type J T/C	Type K T/C				
8 inch - 150 lb ANSI Flange (WATROD)											
23 W/in² Steel Tank 24-Steel (3.6 W/cm²)	240	40.0	1	4	CFRS733D10XS	C/F	C/F	382 (174)	55 ¹ / ₄ (1402.0)	32 ³ / ₄ (830.0)	29 ¹ / ₄ (741.0)
	240	40.0	3	4	CFRS733D3XS	C4-146	C4-147	382 (174)	55 ¹ / ₄ (1402.0)	32 ³ / ₄ (830.0)	29 ¹ / ₄ (741.0)
	480	40.0	1	2	CFRS733D11XS	C/F	C/F	382 (174)	55 ¹ / ₄ (1402.0)	32 ³ / ₄ (830.0)	29 ¹ / ₄ (741.0)
	480	40.0	3	2	CFRS733D5XS	C2-227	C2-228	382 (174)	55 ¹ / ₄ (1402.0)	32 ³ / ₄ (830.0)	29 ¹ / ₄ (741.0)
	240	53.0	3	4	CFRS743M3XS	C4-148	C4-149	425 (193)	62 ¹ / ₄ (1580.0)	39 ³ / ₄ (1008.0)	36 ¹ / ₄ (919.0)
	480	53.0	1	3	CFRS743M11XS	C/F	C/F	425 (193)	62 ¹ / ₄ (1580.0)	39 ³ / ₄ (1008.0)	36 ¹ / ₄ (919.0)
	480	53.0	3	2	CFRS743M5XS	C2-229	C2-230	425 (193)	62 ¹ / ₄ (1580.0)	39 ³ / ₄ (1008.0)	36 ¹ / ₄ (919.0)
	240	67.0	3	4	CFRS751M3XS	C4-148	C4-149	457 (208)	69 ⁷ / ₈ (1774.8)	47 ³ / ₈ (1203.3)	43 ⁷ / ₈ (1114.4)
	480	67.0	1	3	CFRS751M11XS	C/F	C/F	457 (208)	69 ⁷ / ₈ (1774.8)	47 ³ / ₈ (1203.3)	43 ⁷ / ₈ (1114.4)
	480	67.0	3	2	CFRS751M5XS	C2-229	C2-230	457 (208)	69 ⁷ / ₈ (1774.8)	47 ³ / ₈ (1203.3)	43 ⁷ / ₈ (1114.4)
	240	80.0	3	8	CFRS762D3XS	C4-148	C4-149	461 (209)	79 ³ / ₈ (2016.1)	56 ⁷ / ₈ (1444.6)	53 ³ / ₈ (1355.7)
	480	80.0	1	4	CFRS762D11XS	C/F	C/F	461 (209)	79 ³ / ₈ (2016.1)	56 ⁷ / ₈ (1444.6)	53 ³ / ₈ (1355.7)
	480	80.0	3	4	CFRS762D5XS	C4-154	C4-155	461 (209)	79 ³ / ₈ (2016.1)	56 ⁷ / ₈ (1444.6)	53 ³ / ₈ (1355.7)
	240	93.0	3	8	CFRS770M3XS	C/F	C/F	554 (252)	88 ³ / ₈ (2244.7)	65 ⁷ / ₈ (1673.2)	62 ³ / ₈ (1584.3)
	480	93.0	1	6	CFRS770M11XS	C/F	C/F	554 (252)	88 ³ / ₈ (2244.7)	65 ⁷ / ₈ (1673.2)	62 ³ / ₈ (1584.3)
	480	93.0	3	4	CFRS770M5XS	C4-156	C4-157	554 (252)	88 ³ / ₈ (2244.7)	65 ⁷ / ₈ (1673.2)	62 ³ / ₈ (1584.3)
	240	107.0	3	8	CFRS779M3XS	C/F	C/F	636 (289)	98 ³ / ₈ (2498.7)	75 ⁷ / ₈ (1927.2)	72 ³ / ₈ (1838.3)
	480	107.0	3	4	CFRS779M5XS	C4-156	C4-157	636 (289)	98 ³ / ₈ (2498.7)	75 ⁷ / ₈ (1927.2)	72 ³ / ₈ (1838.3)

C/F - Contact factory, go to www.watlow.com/en/contact-us

8 inch - 150 lb ANSI Flange

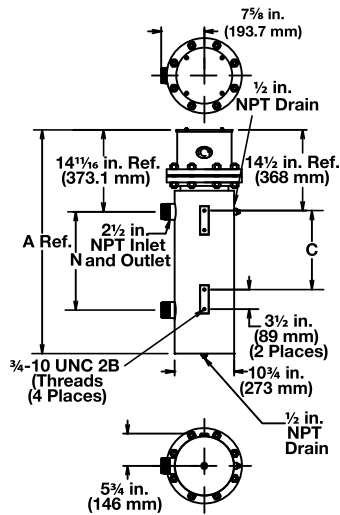

Circulation Heaters



WATROD and FIREBAR Circulation Heaters



Application: Lightweight Oils and Heat Transfer Oils

- WATROD elements
- Without thermostat
- General purpose enclosure

Description	Volts	kW	Ph	# Circ.	Part Number	WATCONNECT Part Number		Ship Wt. lbs (kg)	"A" Dim. in. (mm)	"N" Dim. in. (mm)	"C" Dim. in. (mm)
						Type J T/C	Type K T/C				
10 inch - 150 lb ANSI Flange (WATROD)											
23 W/in ² Steel Tank 27-Steel Elements (3.6 W/cm ²)	480	90.0	3	3	CFSS762E5S	C4-152	C4-153	540 (245)	91 ¹ / ₄ (2316.0)	75 ¹ / ₂ (1916.0)	81 ¹⁵ / ₁₆ (2081.2)
	480	105.0	3	3	CFSS770N5S	C4-152	C4-153	600 (645)	99 ¹ / ₈ (2517.8)	83 ³ / ₈ (2117.7)	89 ¹³ / ₁₆ (2281.2)
	480	120.0	3	3	CFSS778N5S	C4-152	C4-153	645 (293)	106 ⁵ / ₈ (2708.3)	90 ⁷ / ₈ (2308.2)	97 ⁵ / ₁₆ (2471.7)
12 inch - 150 lb ANSI Flange (WATROD)											
23 W/in ² Steel Tank 36-Steel Elements (3.6 W/cm ²)	480	140.0	3	4	CFSS770L5S	C4-156	C4-157	650 (295)	99 (2515)	82 ⁷ / ₈ (2105.0)	89 ⁵ / ₈ (2276.5)
	480	160.0	3	4	CFSS778L5S	C4-156	C4-157	700 (318)	106 ¹ / ₂ (2705)	90 ³ / ₈ (2295.5)	97 ¹ / ₈ (2467.0)
14 inch - 150 lb ANSI Flange (WATROD)											
23 W/in ² Steel Tank 45-Steel Elements (3.6 W/cm ²)	480	150.0	3	5	CFWS762A5S	C/F	C/F	650 (295)	90 ³ / ₄ (2305)	74 ¹ / ₂ (1891)	81 ³ / ₁₆ (2062.2)
	480	175.0	3	5	CFWS770J5S	C/F	C/F	700 (318)	98 ¹ / ₄ (2496)	82 (2081)	88 ¹¹ / ₁₆ (2252.7)
	480	200.0	3	5	CFWS778J5S	C/F	C/F	780 (354)	105 ³ / ₄ (2686)	89 ¹ / ₂ (2272)	96 ³ / ₁₆ (2443.2)

C/F - Contact factory, go to www.watlow.com/en/contact-us

10 inch - 150 lb ANSI Flange

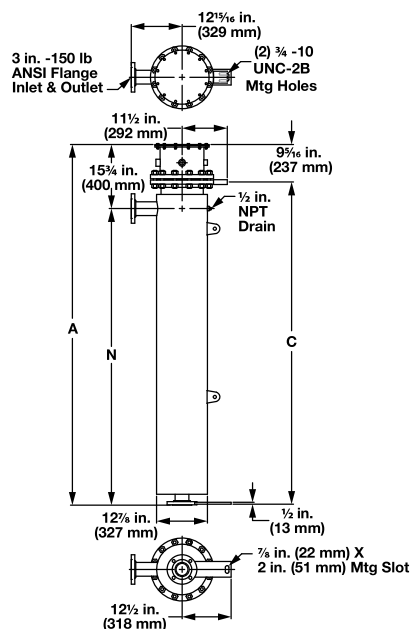

12 inch - 150 lb ANSI Flange

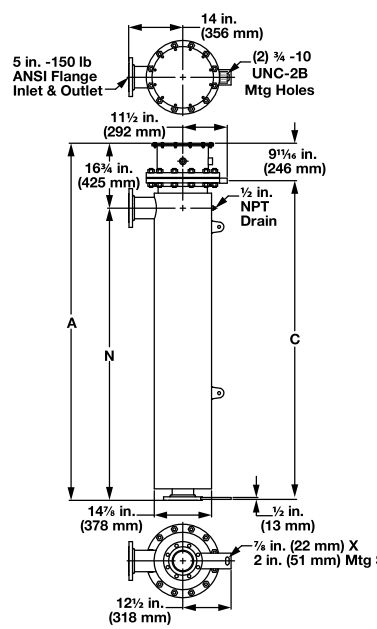

14 inch - 150 lb ANSI Flange

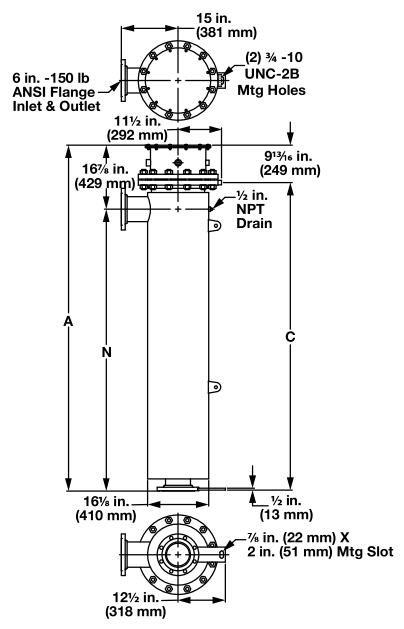



Circulation Heaters

WATROD and FIREBAR Circulation Heaters



Application: Medium Weight Oils and Heat Transfer Oils

- WATROD or FIREBAR elements
- Without thermostat
- General purpose enclosure

Description	Volts	kW	Ph	# Circ.	Part Number	WATCONNECT Part Number		Ship Wt. lbs (kg)	"A" Dim. in. (mm)	"N" Dim. in. (mm)	"C" Dim. in. (mm)
						Type J T/C	Type K T/C				
1 1/4 inch NPT Screw Plug (FIREBAR)											
15 W/in ² ③ Steel Tank 1-Alloy 800 Elements (2.3 W/cm ²)	240	0.67	3	1	CBDNF13A29S	C2-50	C2-92	25 (12)	24 ⁵ / ₈ (625.5)	15 (381)	3 ¹ / ₈ (79.4)
	240	0.83	3	1	CBDNF15J29S	C2-50	C2-92	26 (12)	24 ⁵ / ₈ (625.5)	15 (381)	3 ¹ / ₈ (79.4)
	240	1.00	3	1	CBDNF18A29S	C2-50	C2-92	30 (14)	32 ⁵ / ₈ (828.7)	23 (584)	3 ¹ / ₈ (79.4)
	240	1.33	3	1	CBDNF22J29S	C2-50	C2-92	31 (14)	32 ⁵ / ₈ (828.7)	23 (584)	3 ¹ / ₈ (79.4)
	480	1.33	3	1	CBDNF22J30S	C2-43	C2-35	31 (14)	32 ⁵ / ₈ (828.7)	23 (584)	3 ¹ / ₈ (79.4)
	240	1.67	3	1	CBDNF27J29S	C2-50	C2-92	43 (20)	42 ⁵ / ₈ (1082.7)	32 (813)	4 ³ / ₈ (111.1)
	480	1.67	3	1	CBDNF27J30S	C2-43	C2-35	43 (20)	42 ⁵ / ₈ (1082.7)	32 (813)	4 ³ / ₈ (111.1)
	240	2.00	3	1	CBDNF32J29S	C2-50	C2-92	44 (20)	42 ⁵ / ₈ (1082.7)	32 (813)	4 ³ / ₈ (111.1)
	480	2.00	3	1	CBDNF32J30S	C2-43	C2-35	44 (20)	42 ⁵ / ₈ (1082.7)	32 (813)	4 ³ / ₈ (111.1)
	240	2.67	3	1	CBDNF42A29S	C2-50	C2-92	69 (32)	63 ⁵ / ₈ (1616.1)	53 (1346)	4 ³ / ₈ (111.1)
	480	2.67	3	1	CBDNF42A30S	C2-43	C2-35	69 (32)	63 ⁵ / ₈ (1616.1)	53 (1346)	4 ³ / ₈ (111.1)
	240	3.33	3	1	CBDNF51J29S	C2-50	C2-92	71 (33)	63 ⁵ / ₈ (1616.1)	53 (1346)	4 ³ / ₈ (111.1)
480	3.33	3	1	CBDNF51J30S	C2-43	C2-35	71 (33)	63 ⁵ / ₈ (1616.1)	53 (1346)	4 ³ / ₈ (111.1)	
2 1/2 inch NPT Screw Plug (WATROD)											
16 W/in ² ③ Steel Tank 3-Alloy 800 Elements (2.5 W/cm ²)	240	2.0	3	1	CBLN717G12S	C2-50	C2-92	24 (11)	34 ³ / ₄ (881)	22 ¹ / ₂ (572)	16 ¹ / ₂ (419)
	480	2.0	3	1	CBLN717G13S	C2-43	C2-35	24 (11)	34 ³ / ₄ (881)	22 ¹ / ₂ (572)	16 ¹ / ₂ (419)
	240	2.5	3	1	CBLN719R12S	C2-50	C2-92	26 (12)	34 ³ / ₄ (881)	22 ¹ / ₂ (572)	16 ¹ / ₂ (419)
	480	2.5	3	1	CBLN719R13S	C2-43	C2-35	26 (12)	34 ³ / ₄ (881)	22 ¹ / ₂ (572)	16 ¹ / ₂ (419)
	240	3.0	3	1	CBLN724R12S	C2-50	C2-92	27 (13)	34 ³ / ₄ (881)	22 ¹ / ₂ (572)	16 ¹ / ₂ (419)
	480	3.0	3	1	CBLN724R13S	C2-43	C2-35	27 (13)	34 ³ / ₄ (881)	22 ¹ / ₂ (572)	16 ¹ / ₂ (419)
	240	4.0	3	1	CBLN732G12S	C2-50	C2-92	29 (14)	44 ³ / ₄ (1135)	32 ¹ / ₂ (826)	26 ¹ / ₂ (673)
	480	4.0	3	1	CBLN732G13S	C2-43	C2-35	29 (14)	44 ³ / ₄ (1135)	32 ¹ / ₂ (826)	26 ¹ / ₂ (673)
	240	5.0	3	1	CBLN739R12S	C2-50	C2-92	31 (14)	57 ¹ / ₄ (1453)	45 (1143)	39 (991)
	480	5.0	3	1	CBLN739R13S	C2-43	C2-35	31 (14)	57 ¹ / ₄ (1453)	45 (1143)	39 (991)
	240	6.0	3	1	CBLN747G12S	C2-50	C2-92	32 (15)	57 ¹ / ₄ (1453)	45 (1143)	39 (991)
	480	6.0	3	1	CBLN747G13S	C2-43	C2-35	32 (15)	57 ¹ / ₄ (1453)	45 (1143)	39 (991)
2 1/2 inch NPT Screw Plug (FIREBAR)											
15 W/in ² ③ Steel Tank 3-Alloy 800 Elements (2.3 W/cm ²)	240	2.00	3	1	CBLNF12A29S	C2-50	C2-92	21 (10)	34 ³ / ₄ (881)	22 ¹ / ₂ (572)	16 ¹ / ₂ (419)
	240	2.50	3	1	CBLNF14J29S	C2-50	C2-92	22 (10)	34 ³ / ₄ (881)	22 ¹ / ₂ (572)	16 ¹ / ₂ (419)
	240	3.00	3	1	CBLNF17A29S	C2-50	C2-92	23 (11)	34 ³ / ₄ (881)	22 ¹ / ₂ (572)	16 ¹ / ₂ (419)
	240	4.00	3	1	CBLNF21J29S	C2-50	C2-92	31 (14)	34 ³ / ₄ (881)	22 ¹ / ₂ (572)	16 ¹ / ₂ (419)
	480	4.00	3	1	CBLNF21J30S	C2-43	C2-35	31 (14)	34 ³ / ₄ (881)	22 ¹ / ₂ (572)	16 ¹ / ₂ (419)
	240	5.00	3	1	CBLNF26J29S	C2-50	C2-92	34 (16)	44 ³ / ₄ (1135)	32 ¹ / ₂ (826)	26 ¹ / ₂ (673)
	480	5.00	3	1	CBLNF26J30S	C2-43	C2-35	34 (16)	44 ³ / ₄ (1135)	32 ¹ / ₂ (826)	26 ¹ / ₂ (673)
	240	6.00	3	1	CBLNF31J29S	C2-50	C2-92	35 (16)	44 ³ / ₄ (1135)	32 ¹ / ₂ (826)	26 ¹ / ₂ (673)
	480	6.00	3	1	CBLNF31J30S	C2-43	C2-35	35 (16)	44 ³ / ₄ (1135)	32 ¹ / ₂ (826)	26 ¹ / ₂ (673)
	240	8.00	3	1	CBLNF41A29S	C2-50	C2-92	44 (20)	57 ¹ / ₄ (1453)	45 (1143)	39 (991)
	480	8.00	3	1	CBLNF41A30S	C2-43	C2-35	44 (20)	57 ¹ / ₄ (1453)	45 (1143)	39 (991)
	240	10.00	3	1	CBLNF50J29S	C2-50	C2-92	52 (24)	63 ³ / ₄ (1618)	51 ¹ / ₂ (1308)	46 ¹ / ₂ (1181)
480	10.00	3	1	CBLNF50J30S	C2-43	C2-35	52 (24)	63 ³ / ₄ (1618)	51 ¹ / ₂ (1308)	46 ¹ / ₂ (1181)	

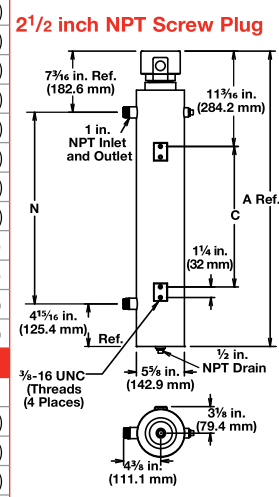
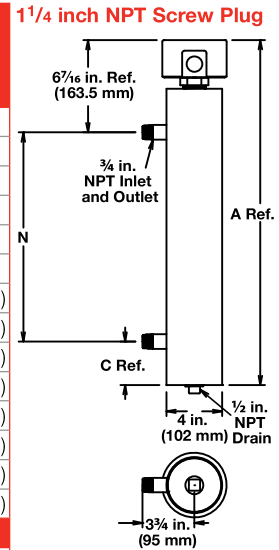

③ Wired for 3-phase operation only

Circulation Heaters



WATROD and FIREBAR Circulation Heaters



Application: Medium Weight Oils and Heat Transfer Oils

- WATROD elements
- Without thermostat
- General purpose enclosure

Description	Volts	kW	Ph	# Circ.	Part Number	WATCONNECT Part Number		Ship Wt. lbs (kg)	"A" Dim. in. (mm)	"N" Dim. in. (mm)	"C" Dim. in. (mm)
						Type J T/C	Type K T/C				
3 inch - 150 lb ANSI Flange (WATROD)											
16 W/in² ③ Steel Tank 3-Alloy 800 Elements (2.6 W/cm²)	240	2.00	3	1	CFMN718A12S	C2-50	C2-92	68 (31)	35 ¹ / ₄ (894)	22 ¹ / ₂ (573)	16 ¹ / ₂ (419)
	480	2.00	3	1	CFMN718A13S	C2-43	C2-35	68 (31)	35 ¹ / ₄ (894)	22 ¹ / ₂ (573)	16 ¹ / ₂ (419)
	240	2.50	3	1	CFMN720J12S	C2-50	C2-92	70 (32)	35 ¹ / ₄ (894)	22 ¹ / ₂ (573)	16 ¹ / ₂ (419)
	480	2.50	3	1	CFMN720J13S	C2-43	C2-35	70 (32)	35 ¹ / ₄ (894)	22 ¹ / ₂ (573)	16 ¹ / ₂ (419)
	240	3.00	3	1	CFMN725J12S	C2-50	C2-92	78 (36)	45 ¹ / ₄ (1148)	32 ¹ / ₂ (826)	26 ¹ / ₂ (673)
	480	3.00	3	1	CFMN725J13S	C2-43	C2-35	78 (36)	45 ¹ / ₄ (1148)	32 ¹ / ₂ (826)	26 ¹ / ₂ (673)
	240	4.00	3	1	CFMN733A12S	C2-50	C2-92	96 (44)	45 ¹ / ₄ (1148)	32 ¹ / ₂ (826)	26 ¹ / ₂ (673)
	480	4.00	3	1	CFMN733A13S	C2-43	C2-35	96 (44)	45 ¹ / ₄ (1148)	32 ¹ / ₂ (826)	26 ¹ / ₂ (673)
	240	5.00	3	1	CFMN740J12S	C2-50	C2-92	100 (46)	57 ³ / ₄ (1465)	45 (1143)	39 (991)
	480	5.00	3	1	CFMN740J13S	C2-43	C2-35	100 (46)	57 ³ / ₄ (1465)	45 (1143)	39 (991)
	240	6.00	3	1	CFMN748A12S	C2-50	C2-92	107 (49)	57 ³ / ₄ (1465)	45 (1143)	39 (991)
	480	6.00	3	1	CFMN748A13S	C2-43	C2-35	107 (49)	57 ³ / ₄ (1465)	45 (1143)	39 (991)
4 inch - 150 lb ANSI Flange (WATROD)											
16 W/in² ③ Steel Tank 6-Alloy 800 Elements (2.5 W/cm²)	240	3.0	3	1	CFON713J12S	C2-50	C2-92	122 (56)	39 (989)	20 ¹ / ₂ (521)	17 (432)
	480	3.0	3	1	CFON713J13S	C2-43	C2-35	122 (56)	39 (989)	20 ¹ / ₂ (521)	17 (432)
	240	4.0	3	1	CFON718A12S	C2-50	C2-92	125 (57)	39 (989)	20 ¹ / ₂ (521)	17 (432)
	480	4.0	3	1	CFON718A13S	C2-43	C2-35	125 (57)	39 (989)	20 ¹ / ₂ (521)	17 (432)
	240	5.0	3	1	CFON720J12S	C2-50	C2-92	127 (58)	39 (989)	20 ¹ / ₂ (521)	17 (432)
	480	5.0	3	1	CFON720J13S	C2-43	C2-35	127 (58)	39 (989)	20 ¹ / ₂ (521)	17 (432)
	240	6.0	3	1	CFON725J12S	C2-50	C2-92	160 (73)	39 (989)	20 ¹ / ₂ (521)	17 (432)
	480	6.0	3	1	CFON725J13S	C2-43	C2-35	160 (73)	39 (989)	20 ¹ / ₂ (521)	17 (432)
	240	8.0	3	1	CFON733A12S	C2-50	C2-92	163 (74)	49 ¹ / ₂ (1256)	31 (787)	27 ¹ / ₂ (699)
	480	8.0	3	1	CFON733A13S	C2-43	C2-35	163 (74)	49 ¹ / ₂ (1256)	31 (787)	27 ¹ / ₂ (699)
	240	10.0	3	1	CFON740J12S	C2-50	C2-92	229 (104)	70 ¹ / ₂ (1789)	52 (1321)	48 ¹ / ₂ (1232)
	480	10.0	3	1	CFON740J13S	C2-43	C2-35	229 (104)	70 ¹ / ₂ (1789)	52 (1321)	48 ¹ / ₂ (1232)
	240	12.0	3	1	CFON748A12S	C2-236	C2-214	234 (107)	70 ¹ / ₂ (1789)	52 (1321)	48 ¹ / ₂ (1232)
	480	12.0	3	1	CFON748A13S	C2-43	C2-35	234 (107)	70 ¹ / ₂ (1789)	52 (1321)	48 ¹ / ₂ (1232)

③ Wired for 3-phase operation only

3 inch - 150 lb ANSI Flange

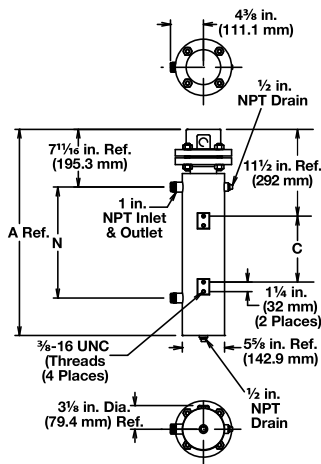

4 inch - 150 lb ANSI Flange

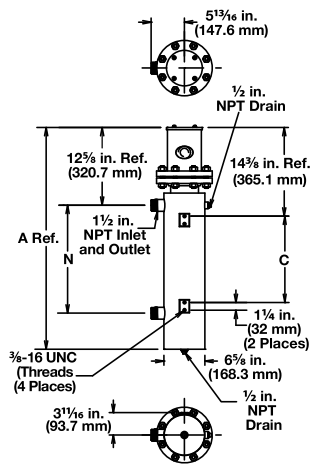

Circulation Heaters



WATROD and FIREBAR Circulation Heaters



Application: Medium Weight Oils and Heat Transfer Oils

- WATROD elements
- Without thermostat
- General purpose enclosure

Description	Volts	kW	Ph	# Circ.	Part Number	WATCONNECT Part Number		Ship Wt. lbs (kg)	"A" Dim. in. (mm)	"N" Dim. in. (mm)	"C" Dim. in. (mm)
						Type J T/C	Type K T/C				
6 inch - 150 lb ANSI Flange (WATROD)											
16 W/in² ③ Steel Tank 12-Alloy 800 Elements (2.6 W/cm²)	240	6.0	3	1	CFPN713G12S	C2-50	C2-92	212 (97)	40 ¹ / ₂ (1027)	20 ¹ / ₂ (521)	17 (432)
	480	6.0	3	1	CFPN713G13S	C2-43	C2-35	212 (97)	40 ¹ / ₂ (1027)	20 ¹ / ₂ (521)	17 (432)
	240	8.0	3	1	CFPN717R12S	C2-50	C2-92	214 (97)	40 ¹ / ₂ (1027)	20 ¹ / ₂ (521)	17 (432)
	480	8.0	3	1	CFPN717R13S	C2-43	C2-35	214 (97)	40 ¹ / ₂ (1027)	20 ¹ / ₂ (521)	17 (432)
	240	10.0	3	1	CFPN720G12S	C2-50	C2-92	217 (99)	40 ¹ / ₂ (1027)	20 ¹ / ₂ (521)	17 (432)
	480	10.0	3	1	CFPN720G13S	C2-43	C2-35	217 (99)	40 ¹ / ₂ (1027)	20 ¹ / ₂ (521)	17 (432)
	240	12.0	3	1	CFPN725G12S	C2-236	C2-214	222 (101)	40 ¹ / ₂ (1027)	20 ¹ / ₂ (521)	17 (432)
	480	12.0	3	1	CFPN725G13S	C2-43	C2-35	222 (101)	40 ¹ / ₂ (1027)	20 ¹ / ₂ (521)	17 (432)
	240	16.0	3	1	CFPN732R12S	C2-236	C2-214	226 (103)	51 (1294)	31 (787)	27 ¹ / ₂ (699)
	480	16.0	3	1	CFPN732R13S	C2-43	C2-35	226 (103)	51 (1294)	31 (787)	27 ¹ / ₂ (699)
	240	20.0	3	2	CFPN740G12S	C2-219	C2-220	290 (132)	72 (1827)	52 (1321)	48 ¹ / ₂ (1232)
	480	20.0	3	1	CFPN740G13S	C2-43	C2-35	290 (132)	72 (1827)	52 (1321)	48 ¹ / ₂ (1232)
	240	24.0	3	2	CFPN747R12S	C2-219	C2-220	298 (136)	72 (1827)	52 (1321)	48 ¹ / ₂ (1232)
	480	24.0	3	1	CFPN747R13S	C2-225	C2-226	298 (136)	72 (1827)	52 (1321)	48 ¹ / ₂ (1232)
	6 inch - 150 lb ANSI Flange (WATROD)										
16 W/in² ③ Steel Tank 15-Alloy 800 Elements (2.6 W/cm²)	240	7.50	3	1	CFPN713G12XS	C2-50	C2-92	215 (98)	40 ¹ / ₂ (1027)	20 ¹ / ₂ (521)	17 (432)
	480	7.50	3	1	CFPN713G13XS	C2-43	C2-35	215 (98)	40 ¹ / ₂ (1027)	20 ¹ / ₂ (521)	17 (432)
	240	10.0	3	1	CFPN717R12XS	C2-50	C2-92	217 (99)	40 ¹ / ₂ (1027)	20 ¹ / ₂ (521)	17 (432)
	480	10.0	3	1	CFPN717R13XS	C2-43	C2-35	217 (99)	40 ¹ / ₂ (1027)	20 ¹ / ₂ (521)	17 (432)
	240	12.5	3	1	CFPN720G12XS	C2-236	C2-214	223 (102)	40 ¹ / ₂ (1027)	20 ¹ / ₂ (521)	17 (432)
	480	12.5	3	1	CFPN720G13XS	C2-43	C2-35	223 (102)	40 ¹ / ₂ (1027)	20 ¹ / ₂ (521)	17 (432)
	240	15.0	3	1	CFPN725G12XS	C2-236	C2-214	226 (103)	40 ¹ / ₂ (1027)	20 ¹ / ₂ (521)	17 (432)
	480	15.0	3	1	CFPN725G13XS	C2-43	C2-35	226 (103)	40 ¹ / ₂ (1027)	20 ¹ / ₂ (521)	17 (432)
	240	20.0	3	5	CFPN732R12XS	C4-143	C4-142	288 (131)	51 (1294)	31 (787)	27 ¹ / ₂ (699)
	480	20.0	3	1	CFPN732R13XS	C2-43	C2-35	288 (131)	51 (1294)	31 (787)	27 ¹ / ₂ (699)
	240	25.0	3	5	CFPN740G12XS	C4-143	C4-142	296 (135)	72 (1827)	52 (1321)	48 ¹ / ₂ (1232)
	480	25.0	3	1	CFPN740G13XS	C2-225	C2-226	296 (135)	72 (1827)	52 (1321)	48 ¹ / ₂ (1232)
	240	30.0	3	5	CFPN747R12XS	C4-144	C4-145	306 (139)	72 (1827)	52 (1321)	48 ¹ / ₂ (1232)
	480	30.0	3	1	CFPN747R13XS	C2-225	C2-226	306 (139)	72 (1827)	52 (1321)	48 ¹ / ₂ (1232)

③ Wired for 3-phase operation only

6 inch - 150 lb ANSI Flange

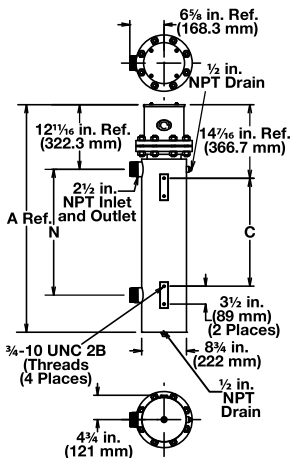

Circulation Heaters



WATROD and FIREBAR Circulation Heaters



Application: Medium Weight Oils and Heat Transfer Oils

- WATROD elements
- Without thermostat
- General purpose enclosure

Description	Volts	kW	Ph	# Circ.	Part Number	WATCONNECT Part Number		Ship Wt. lbs (kg)	"A" Dim. in. (mm)	"N" Dim. in. (mm)	"C" Dim. in. (mm)
						Type J T/C	Type K T/C				
8 inch - 150 lb ANSI Flange (WATROD)											
16 W/in² ③ Steel Tank 18-Alloy 800 Elements (2.6 W/cm²)	240	17.00	3	1	CFRN725N12S	C2-236	C2-214	350 (159)	55 ¹ / ₄ (1402.0)	32 ³ / ₄ (830.0)	29 ¹ / ₄ (741.0)
	480	17.00	3	1	CFRN725N13S	C2-43	C2-35	350 (159)	55 ¹ / ₄ (1402.0)	32 ³ / ₄ (830.0)	29 ¹ / ₄ (741.0)
	240	25.00	3	2	CFRN735N12S	C2-219	C2-220	380 (173)	62 ¹ / ₄ (1580.0)	39 ³ / ₄ (1008.0)	36 ¹ / ₄ (919.0)
	480	25.00	3	1	CFRN735N13S	C2-225	C2-226	380 (173)	62 ¹ / ₄ (1580.0)	39 ³ / ₄ (1008.0)	36 ¹ / ₄ (919.0)
	240	33.00	3	2	CFRN744E12S	C2-218	C2-224	410 (186)	69 ⁷ / ₈ (1774.8)	47 ³ / ₈ (1203.3)	43 ⁷ / ₈ (1114.4)
	480	33.00	3	1	CFRN744E13S	C2-225	C2-226	410 (186)	69 ⁷ / ₈ (1774.8)	47 ³ / ₈ (1203.3)	43 ⁷ / ₈ (1114.4)
	240	42.00	3	3	CFRN754M12S	C4-144	C4-145	445 (202)	79 ³ / ₈ (2016.1)	56 ⁷ / ₈ (1444.6)	53 ³ / ₈ (1355.7)
	480	42.00	3	2	CFRN754M13S	C2-229	C2-230	445 (202)	79 ³ / ₈ (2016.1)	56 ⁷ / ₈ (1444.6)	53 ³ / ₈ (1355.7)
	480	50.00	3	2	CFRN763M13S	C2-229	C2-230	490 (223)	88 ³ / ₈ (2244.7)	65 ⁷ / ₈ (1673.2)	62 ³ / ₈ (1584.3)
	480	58.00	3	2	CFRN773D13S	C2-229	C2-230	530 (241)	98 ³ / ₈ (2498.7)	75 ⁷ / ₈ (1927.2)	72 ³ / ₈ (1838.3)
480	67.00	3	2	CFRN782M13S	C2-229	C2-230	560 (254)	98 ³ / ₈ (2498.7)	75 ⁷ / ₈ (1927.2)	72 ³ / ₈ (1838.3)	
8 inch - 150 lb ANSI Flange (WATROD)											
16 W/in² ③ Steel Tank 24-Alloy 800 Elements (2.6 W/cm²)	240	23.0	3	2	CFRN726D12XS	C2-218	C2-224	358 (163)	55 ¹ / ₄ (1402.0)	32 ³ / ₄ (830.0)	29 ¹ / ₄ (741.0)
	480	23.0	3	1	CFRN726D13XS	C2-225	C2-226	358 (163)	55 ¹ / ₄ (1402.0)	32 ³ / ₄ (830.0)	29 ¹ / ₄ (741.0)
	240	33.0	3	2	CFRN736D12XS	C2-218	C2-224	392 (178)	62 ¹ / ₄ (1580.0)	39 ³ / ₄ (1008.0)	36 ¹ / ₄ (919.0)
	480	33.0	3	1	CFRN736D13XS	C2-225	C2-226	392 (178)	62 ¹ / ₄ (1580.0)	39 ³ / ₄ (1008.0)	36 ¹ / ₄ (919.0)
	240	44.0	3	4	CFRN744M12XS	C4-148	C4-149	425 (193)	69 ⁷ / ₈ (1774.8)	47 ³ / ₈ (1203.3)	43 ⁷ / ₈ (1114.4)
	480	44.0	3	2	CFRN744M13XS	C2-229	C2-230	425 (193)	69 ⁷ / ₈ (1774.8)	47 ³ / ₈ (1203.3)	43 ⁷ / ₈ (1114.4)
	240	56.0	3	4	CFRN754M12XS	C4-148	C4-149	463 (210)	79 ³ / ₈ (2016.1)	56 ⁷ / ₈ (1444.6)	53 ³ / ₈ (1355.7)
	480	56.0	3	2	CFRN754M13XS	C2-229	C2-230	463 (210)	79 ³ / ₈ (2016.1)	56 ⁷ / ₈ (1444.6)	53 ³ / ₈ (1355.7)
	480	67.0	3	2	CFRN763M13XS	C2-229	C2-230	511 (232)	88 ³ / ₈ (2244.7)	65 ⁷ / ₈ (1673.2)	62 ³ / ₈ (1584.3)
	480	77.0	3	2	CFRN773D13XS	C2-229	C2-230	554 (252)	98 ³ / ₈ (2498.7)	75 ⁷ / ₈ (1927.2)	72 ³ / ₈ (1838.3)
	480	89.0	3	4	CFRN782M13XS	C4-156	C4-157	587 (267)	98 ³ / ₈ (2498.7)	75 ⁷ / ₈ (1927.2)	72 ³ / ₈ (1838.3)

③ Wired for 3-phase operation only

8 inch - 150 lb ANSI Flange

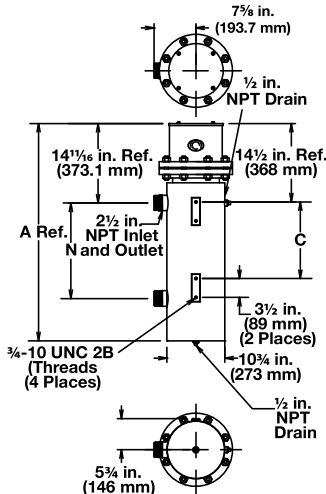

Circulation Heaters



WATROD and FIREBAR Circulation Heaters



Application: Medium Weight Oils and Heat Transfer Oils

- WATROD elements
- Without thermostat
- General purpose enclosure

Description	Volts	kW	Ph	# Circ.	Part Number	WATCONNECT Part Number		Ship Wt. lbs (kg)	"A" Dim. in. (mm)	"N" Dim. in. (mm)	"C" Dim. in. (mm)
						Type J T/C	Type K T/C				
10 inch - 150 lb ANSI Flange (WATROD)											
16 W/in ² ^③ Steel Tank 27-Alloy 800 Elements (2.6 W/cm ²)	480	75.0	3	3	CFSN763N13S	C4-152	C4-153	540 (245)	91 ³ / ₁₆ (2316)	75 ⁷ / ₁₆ (1916)	81 ¹⁵ / ₁₆ (2081)
	480	87.0	3	3	CFSN773E13S	C4-152	C4-153	600 (273)	106 ⁹ / ₁₆ (2707)	90 ¹³ / ₁₆ (1037)	97 ⁵ / ₁₆ (2471)
12 inch - 150 lb ANSI Flange (WATROD)											
16 W/in ² ^③ Steel Tank 36-Alloy 800 Elements (2.6 W/cm ²)	480	117.0	3	3	CFTN773C13S	C4-152	C4-153	650 (295)	106 ¹ / ₂ (2705)	90 ³ / ₈ (2295.5)	97 ³ / ₁₆ (2468.6)
14 inch - 150 lb ANSI Flange (WATROD)											
16 W/in ² ^③ Steel Tank 45-Alloy 800 Elements (2.6 W/cm ²)	480	105.0	3	3	CFWN754J13S	C4-152	C4-153	600 (273)	83 ¹ / ₄ (2115)	67 (1700)	73 ¹¹ / ₁₆ (1872)
	480	125.0	3	5	CFWN763J13S	C/F	C/F	650 (295)	90 ³ / ₄ (2305)	74 ¹ / ₂ (1891)	81 ³ / ₁₆ (2062)

③ Wired for 3-phase operation only

C/F - Contact factory, go to www.watlow.com/en/contact-us

10 inch - 150 lb ANSI Flange

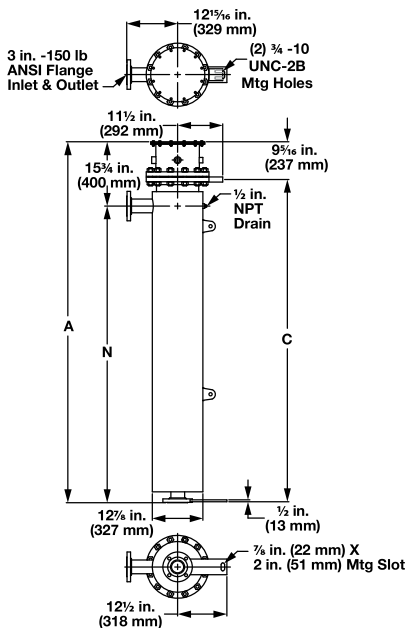

12 inch - 150 lb ANSI Flange

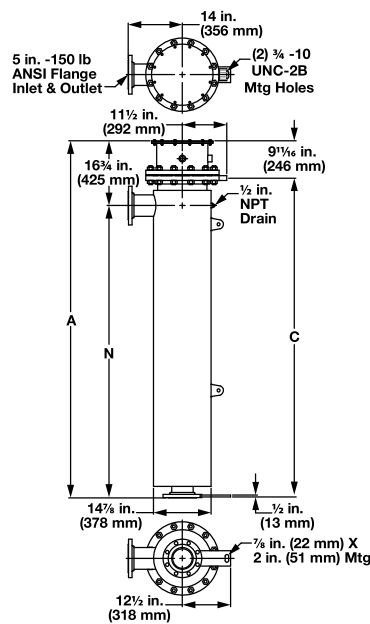

14 inch - 150 lb ANSI Flange

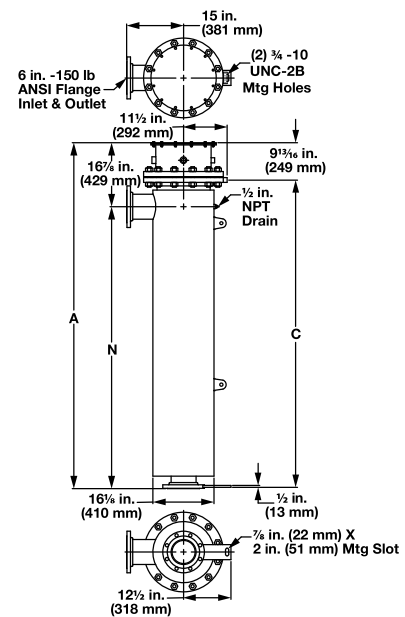

Circulation Heaters



WATROD and FIREBAR Circulation Heaters



Application: Bunker C, Asphalt and #6 Fuel Oil

- WATROD or FIREBAR elements
- Without thermostat
- General purpose enclosure

Description	Volts	kW	Ph	# Circ.	Part Number	WATCONNECT Part Number		Ship Wt. lbs (kg)	"A" Dim. in. (mm)	"N" Dim. in. (mm)	"C" Dim. in. (mm)
						Type J T/C	Type K T/C				
1 1/4 inch NPT Screw Plug (FIREBAR)											
8 W/in² ③ Steel Tank 1-Alloy 800 Element (1.3 W/cm²)	240	0.43	3	1	CBDNF16G22S	C2-50	C2-92	26 (12)	24 ⁵ / ₈ (625.5)	15 (381)	3 ¹ / ₈ (79.4)
	240	0.55	3	1	CBDNF19G22S	C2-50	C2-92	30 (14)	32 ⁵ / ₈ (828.7)	23 (584)	3 ¹ / ₈ (79.4)
	240	0.70	3	1	CBDNF24L22S	C2-50	C2-92	31 (14)	32 ⁵ / ₈ (828.7)	23 (584)	3 ¹ / ₈ (79.4)
	480	0.70	3	1	CBDNF24L21S	C2-43	C2-35	31 (14)	32 ⁵ / ₈ (828.7)	23 (584)	3 ¹ / ₈ (79.4)
	240	0.88	3	1	CBDNF29R22S	C2-50	C2-92	43 (20)	42 ⁵ / ₈ (1082.7)	32 (813)	4 ³ / ₈ (111.1)
	480	0.88	3	1	CBDNF29R21S	C2-43	C2-35	43 (20)	42 ⁵ / ₈ (1082.7)	32 (813)	4 ³ / ₈ (111.1)
	240	1.08	3	1	CBDNF34R22S	C2-50	C2-92	44 (20)	42 ⁵ / ₈ (1082.7)	32 (813)	4 ³ / ₈ (111.1)
	480	1.08	3	1	CBDNF34R21S	C2-43	C2-35	44 (20)	42 ⁵ / ₈ (1082.7)	32 (813)	4 ³ / ₈ (111.1)
	240	1.40	3	1	CBDNF45G22S	C2-50	C2-92	69 (31)	63 ⁵ / ₈ (1616.1)	53 (1346)	4 ³ / ₈ (111.1)
	480	1.40	3	1	CBDNF45G21S	C2-43	C2-35	69 (31)	63 ⁵ / ₈ (1616.1)	53 (1346)	4 ³ / ₈ (111.1)
	240	1.80	3	1	CBDNF55R22S	C2-50	C2-92	71 (32)	63 ⁵ / ₈ (1616.1)	53 (1346)	4 ³ / ₈ (111.1)
480	1.80	3	1	CBDNF55R21S	C2-43	C2-35	71 (32)	63 ⁵ / ₈ (1616.1)	53 (1346)	4 ³ / ₈ (111.1)	
2 1/2 inch NPT Screw Plug (WATROD)											
8 W/in² ③ Steel Tank 3-Steel Elements (1.3 W/cm²)	240	2.0	3	1	CBLS732E12S	C2-50	C2-92	29 (14)	44 ³ / ₄ (1135)	32 ¹ / ₂ (826)	26 ¹ / ₂ (673)
	480	2.0	3	1	CBLS732E13S	C2-43	C2-35	29 (14)	44 ³ / ₄ (1135)	32 ¹ / ₂ (826)	26 ¹ / ₂ (673)
	240	3.0	3	1	CBLS747E12S	C2-50	C2-92	32 (15)	57 ¹ / ₄ (1453)	45 (1143)	39 (991)
	480	3.0	3	1	CBLS747E13S	C2-43	C2-35	32 (15)	57 ¹ / ₄ (1453)	45 (1143)	39 (991)

③ Wired for 3-phase operation only

1 1/4 inch NPT Screw Plug

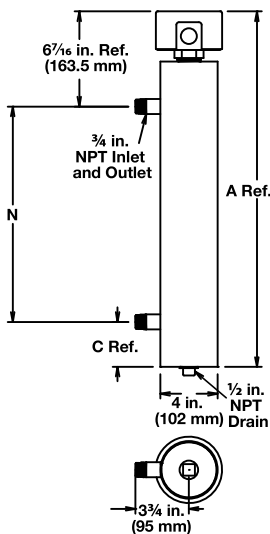

2 1/2 inch NPT Screw Plug

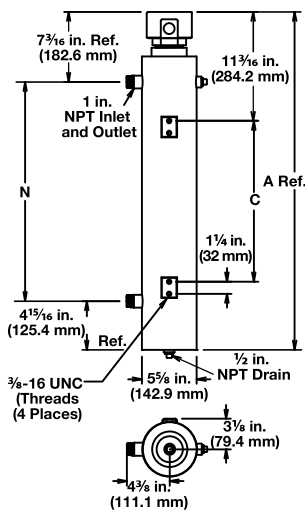

Circulation Heaters



WATROD and FIREBAR Circulation Heaters

Application: Bunker C, Asphalt and #6 Fuel Oil

- WATROD or FIREBAR elements
- Without thermostat
- General purpose enclosure

Description	Volts	kW	Ph	# Circ.	Part Number	WATCONNECT Part Number		Ship Wt. lbs (kg)	"A" Dim. in. (mm)	"N" Dim. in. (mm)	"C" Dim. in. (mm)
						Type J T/C	Type K T/C				
2 1/2 inch NPT Screw Plug (FIREBAR)											
8 W/in² ③ Steel Tank 3-Alloy 800 Elements (1.3 W/cm²)	240	1.25	3	1	CBLNF15C22S	C2-50	C2-92	22 (10)	34 ³ / ₄ (881)	22 ¹ / ₂ (572)	16 ¹ / ₂ (419)
	240	1.63	3	1	CBLNF18C22S	C2-50	C2-92	23 (10)	34 ³ / ₄ (881)	22 ¹ / ₂ (572)	16 ¹ / ₂ (419)
	240	2.13	3	1	CBLNF23C22S	C2-50	C2-92	31 (14)	34 ³ / ₄ (881)	22 ¹ / ₂ (572)	16 ¹ / ₂ (419)
	480	2.13	3	1	CBLNF23C21S	C2-43	C2-35	31 (14)	34 ³ / ₄ (881)	22 ¹ / ₂ (572)	16 ¹ / ₂ (419)
	240	2.63	3	1	CBLNF28L22S	C2-50	C2-92	34 (15)	44 ³ / ₄ (1135)	32 ¹ / ₂ (826)	26 ¹ / ₂ (673)
	480	2.63	3	1	CBLNF28L21S	C2-43	C2-35	34 (15)	44 ³ / ₄ (1135)	32 ¹ / ₂ (826)	26 ¹ / ₂ (673)
	240	3.19	3	1	CBLNF33L22S	C2-50	C2-92	35 (16)	44 ³ / ₄ (1135)	32 ¹ / ₂ (826)	26 ¹ / ₂ (673)
	480	3.19	3	1	CBLNF33L21S	C2-43	C2-35	35 (16)	44 ³ / ₄ (1135)	32 ¹ / ₂ (826)	26 ¹ / ₂ (673)
	240	4.25	3	1	CBLNF44C22S	C2-50	C2-92	44 (20)	57 ¹ / ₄ (1453)	45 (1143)	39 (991)
	480	4.25	3	1	CBLNF44C21S	C2-43	C2-35	44 (20)	57 ¹ / ₄ (1453)	45 (1143)	39 (991)
	240	5.38	3	1	CBLNF54L22S	C2-50	C2-92	52 (24)	63 ³ / ₄ (1453)	51 ¹ / ₂ (1308)	46 ¹ / ₂ (1181)
	480	5.38	3	1	CBLNF54L21S	C2-43	C2-35	52 (24)	63 ³ / ₄ (1453)	51 ¹ / ₂ (1308)	46 ¹ / ₂ (1181)
3 inch - 150 lb ANSI Flange (WATROD)											
8 W/in² ③ Steel Tank 3-Steel Elements (1.3 W/cm²)	240	2.0	3	1	CFMS733A12S	C2-50	C2-92	96 (44)	45 ¹ / ₄ (1148)	32 ¹ / ₂ (826)	26 ¹ / ₂ (673)
	480	2.0	3	1	CFMS733A13S	C2-43	C2-35	96 (44)	45 ¹ / ₄ (1148)	32 ¹ / ₂ (826)	26 ¹ / ₂ (673)
	240	3.0	3	1	CFMS748A12S	C2-50	C2-92	107 (49)	57 ³ / ₄ (1465)	45 (1143)	39 (991)
	480	3.0	3	1	CFMS748A13S	C2-43	C2-35	107 (49)	57 ³ / ₄ (1465)	45 (1143)	39 (991)

③ Wired for 3-phase operation only

2 1/2 inch NPT Screw Plug

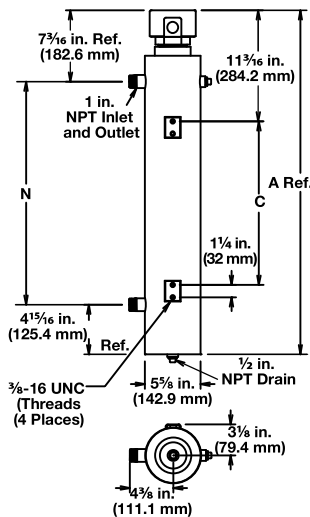

3 inch - 150 lb ANSI Flange

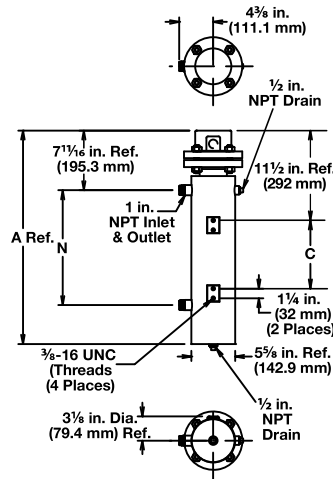

Circulation Heaters



WATROD and FIREBAR Circulation Heaters



Application: Bunker C, Asphalt and #6 Fuel Oil

- WATROD elements
- Without thermostat
- General purpose enclosure

Description	Volts	kW	Ph	# Circ.	Part Number	WATCONNECT Part Number		Ship Wt. lbs (kg)	"A" Dim. in. (mm)	"N" Dim. in. (mm)	"C" Dim. in. (mm)
						Type J T/C	Type K T/C				
4 inch - 150 lb ANSI Flange (WATROD)											
8 W/in ² ③ Steel Tank 6-Steel Elements (1.3 W/cm ²)	240	5.00	3	1	CFOS740J12S	C2-50	C2-92	229 (104)	70 1/2 (1789)	52 (1321)	48 1/2 (1232)
	480	5.00	3	1	CFOS740J13S	C2-43	C2-35	229 (104)	70 1/2 (1789)	52 (1321)	48 1/2 (1232)
	240	6.00	3	1	CFOS748A12S	C2-50	C2-92	234 (106)	70 1/2 (1789)	52 (1321)	48 1/2 (1232)
	480	6.00	3	1	CFOS748A13S	C2-43	C2-35	234 (106)	70 1/2 (1789)	52 (1321)	48 1/2 (1232)
	240	8.00	3	1	CFOS764J12S	C2-50	C2-92	298 (135)	91 1/2 (2326)	73 (1854)	66 (1676)
	480	8.00	3	1	CFOS764J13S	C2-43	C2-35	298 (135)	91 1/2 (2326)	73 (1854)	66 (1676)
	240	10.00	3	1	CFOS777A12S	C2-50	C2-92	306 (139)	91 1/2 (2326)	73 (1854)	66 (1676)
	480	10.00	3	1	CFOS777A13S	C2-43	C2-35	306 (139)	91 1/2 (2326)	73 (1854)	66 (1676)
5 inch - 150 lb ANSI Flange (WATROD)											
8 W/in ² ③ Steel Tank 6-Steel Elements (1.3 W/cm ²)	240	5.00	3	1	CFNS740J12S	C2-50	C2-92	167 (76)	56 1/4 (1427.0)	37 (940.0)	25 (633.0)
	480	5.00	3	1	CFNS740J13S	C2-43	C2-35	167 (76)	56 1/4 (1427.0)	37 (940.0)	25 (633.0)
	240	6.00	3	1	CFNS748A12S	C2-50	C2-92	180 (82)	67 3/4 (1719.0)	48 1/2 (1232.0)	25 (633.0)
	480	6.00	3	1	CFNS748A13S	C2-43	C2-35	180 (82)	67 3/4 (1719.0)	48 1/2 (1232.0)	25 (633.0)
	240	8.00	3	1	CFNS764J12S	C2-50	C2-92	195 (89)	81 1/8 (2060.6)	61 7/8 (1571.6)	25 (633.0)
	480	8.00	3	1	CFNS764J13S	C2-43	C2-35	195 (89)	81 1/8 (2060.6)	61 7/8 (1571.6)	25 (633.0)
	240	10.00	3	1	CFNS777A12S	C2-50	C2-92	220 (100)	94 1/8 (2390.8)	75 (1902.0)	25 (633.0)
	480	10.00	3	1	CFNS777A13S	C2-43	C2-35	220 (100)	94 1/8 (2390.8)	75 (1902.0)	25 (633.0)
5 inch - 150 lb ANSI Flange (WATROD)											
8 W/in ² ③ Steel Tank 9-Steel Elements (1.3 W/cm ²)	240	7.5	3	1	CFNS740J12XS	C2-50	C2-92	173 (79)	56 1/4 (1427.0)	37 (940.0)	25 (633.0)
	480	7.5	3	1	CFNS740J13XS	C2-43	C2-35	173 (79)	56 1/4 (1427.0)	37 (940.0)	25 (633.0)
	240	9.0	3	1	CFNS748A12XS	C2-50	C2-92	188 (86)	67 3/4 (1719.0)	48 1/2 (1232.0)	25 (633.0)
	480	9.0	3	1	CFNS748A13XS	C2-43	C2-35	188 (86)	67 3/4 (1719.0)	48 1/2 (1232.0)	25 (633.0)
	240	12.0	3	1	CFNS764J12XS	C2-236	C2-214	206 (94)	81 1/8 (2060.6)	61 7/8 (1571.6)	25 (633.0)
	480	12.0	3	1	CFNS764J13XS	C2-43	C2-35	206 (94)	81 1/8 (2060.6)	61 7/8 (1571.6)	25 (633.0)
	240	15.0	3	1	CFNS777A12XS	C2-236	C2-214	233 (106)	94 1/8 (2390.8)	75 (1902.0)	25 (633.0)
	480	15.0	3	1	CFNS777A13XS	C2-225	C2-226	233 (106)	94 1/8 (2390.8)	75 (1902.0)	25 (633.0)

③ Wired for 3-phase operation only

4 inch - 150 lb ANSI Flange

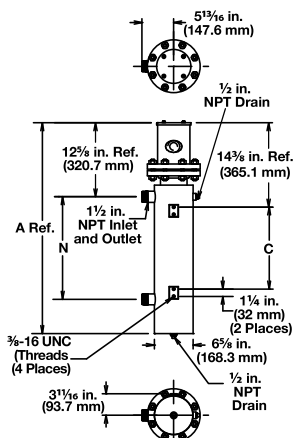

5 inch - 150 lb ANSI Flange

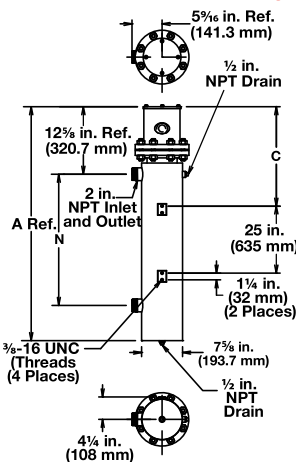

Circulation Heaters



WATROD and FIREBAR Circulation Heaters

Application: Bunker C, Asphalt and #6 Fuel Oil

- WATROD elements
- Without thermostat
- General purpose enclosure

Description	Volts	kW	Ph	# Circ.	Part Number	WATCONNECT Part Number		Ship Wt. lbs (kg)	"A" Dim. in. (mm)		"N" Dim. in. (mm)		"C" Dim. in. (mm)	
						Type J T/C	Type K T/C							
6 inch - 150 lb ANSI Flange (WATROD)														
8 W/in² ③ Steel Tank 12-Steel Elements (1.3 W/cm²)	240	8.0	3	1	CFPS732R12S	C2-50	C2-92	226 (103)	51 (1294)	31 (787)	27 1/2 (699)			
	480	8.0	3	1	CFPS732R13S	C2-43	C2-35	226 (103)	51 (1294)	31 (787)	27 1/2 (699)			
	240	10.0	3	1	CFPS740G12S	C2-50	C2-92	290 (132)	72 (1827)	52 (1321)	48 1/2 (1232)			
	480	10.0	3	1	CFPS740G13S	C2-43	C2-35	290 (132)	72 (1827)	52 (1321)	48 1/2 (1232)			
	240	12.0	3	1	CFPS747R12S	C2-236	C2-214	298 (136)	72 (1827)	52 (1321)	48 1/2 (1232)			
	480	12.0	3	1	CFPS747R13S	C2-43	C2-35	298 (136)	72 (1827)	52 (1321)	48 1/2 (1232)			
	240	16.5	3	1	CFPS764G12S	C2-236	C2-214	360 (164)	93 (2361)	73 (1854)	66 (1676)			
	480	16.5	3	1	CFPS764G13S	C2-43	C2-35	360 (164)	93 (2361)	73 (1854)	66 (1676)			
480	20.0	3	1	CFPS776R13S	C2-43	C2-35	368 (167)	93 (2361)	73 (1854)	66 (1676)				
6 inch - 150 lb ANSI Flange (WATROD)														
8 W/in² ③ Steel Tank 15-Steel Elements (1.3 W/cm²)	240	10.0	3	1	CFPS732R12XS	C2-50	C2-92	288 (131)	51 (1294)	31 (787)	27 1/2 (699)			
	480	10.0	3	1	CFPS732R13XS	C2-43	C2-35	288 (131)	51 (1294)	31 (787)	27 1/2 (699)			
	240	12.5	3	1	CFPS740G12XS	C2-236	C2-214	296 (135)	72 (1827)	52 (1321)	48 1/2 (1232)			
	480	12.5	3	1	CFPS740G13XS	C2-43	C2-35	296 (135)	72 (1827)	52 (1321)	48 1/2 (1232)			
	240	15.0	3	1	CFPS747R12XS	C2-236	C2-214	306 (139)	72 (1827)	52 (1321)	48 1/2 (1232)			
	480	15.0	3	1	CFPS747R13XS	C2-43	C2-35	306 (139)	72 (1827)	52 (1321)	48 1/2 (1232)			
	240	21.0	3	5	CFPS764G12XS	C4-143	C4-142	370 (168)	93 (2361)	73 (1854)	66 (1676)			
	480	21.0	3	1	CFPS764G13XS	C2-225	C2-226	370 (168)	93 (2361)	73 (1854)	66 (1676)			
	240	25.0	3	5	CFPS776R12XS	C4-143	C4-142	381 (173)	93 (2361)	73 (1854)	66 (1676)			
480	25.0	3	1	CFPS776R13XS	C2-224	C2-226	381 (173)	93 (2361)	73 (1854)	66 (1676)				

③ Wired for 3-phase operation only

6 inch - 150 lb ANSI Flange

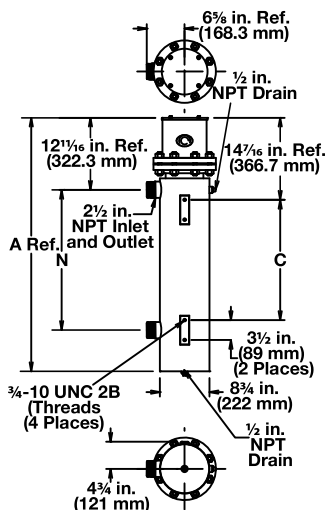

Circulation Heaters



WATROD and FIREBAR Circulation Heaters



Application: Bunker C, Asphalt and #6 Fuel Oil

- WATROD elements
- Without thermostat
- General purpose enclosure

Description	Volts	kW	Ph	# Circ.	Part Number	WATCONNECT Part Number		Ship Wt. lbs (kg)	"A" Dim. in. (mm)	"N" Dim. in. (mm)	"C" Dim. in. (mm)
						Type J T/C	Type K T/C				
8 inch - 150 lb ANSI Flange (WATROD)											
8 W/in² ^③ Steel Tank 18-Steel Elements (1.3 W/cm²)	240	12.5	3	1	CFRS743E12S	C2-236	C2-214	410 (186)	62 ¹ / ₄ (1580.0)	39 ³ / ₄ (1008.0)	36 ¹ / ₄ (919.0)
	480	12.5	3	1	CFRS743E13S	C2-43	C2-35	410 (186)	62 ¹ / ₄ (1580.0)	39 ³ / ₄ (1008.0)	36 ¹ / ₄ (919.0)
	240	16.5	3	1	CFRS751M12S	C2-236	C2-214	440 (200)	69 ⁷ / ₈ (1774.8)	47 ³ / ₈ (1203.3)	43 ⁷ / ₈ (1114.4)
	480	16.5	3	1	CFRS751M13S	C2-43	C2-35	440 (200)	69 ⁷ / ₈ (1774.8)	47 ³ / ₈ (1203.3)	43 ⁷ / ₈ (1114.4)
	240	20.0	3	2	CFRS762D12S	C2-219	C2-220	480 (218)	79 ³ / ₈ (2016.1)	56 ⁷ / ₈ (1444.6)	53 ³ / ₈ (1355.7)
	480	20.0	3	1	CFRS762D13S	C2-43	C2-50	480 (218)	79 ³ / ₈ (2016.1)	56 ⁷ / ₈ (1444.6)	53 ³ / ₈ (1355.7)
	240	24.0	3	2	CFRS770M12S	C2-218	C2-224	530 (241)	88 ³ / ₈ (2244.7)	65 ⁷ / ₈ (1673.2)	62 ³ / ₈ (1584.3)
	480	24.0	3	1	CFRS770M13S	C2-225	C2-226	530 (241)	88 ³ / ₈ (2244.7)	65 ⁷ / ₈ (1673.2)	62 ³ / ₈ (1584.3)
	240	27.0	3	2	CFRS779M12S	C2-218	C2-224	610 (277)	98 ³ / ₈ (2498.7)	75 ⁷ / ₈ (1927.2)	72 ³ / ₈ (1838.3)
480	27.0	3	1	CFRS779M13S	C2-225	C2-226	610 (277)	98 ³ / ₈ (2498.7)	75 ⁷ / ₈ (1927.2)	72 ³ / ₈ (1838.3)	
8 inch - 150 lb ANSI Flange (WATROD)											
8 W/in² ^③ Steel Tank 24-Steel Elements (1.3 W/cm²)	240	17.0	3	1	CFRS743M12XS	C2-236	C2-214	425 (193)	62 ¹ / ₄ (1580.0)	39 ³ / ₄ (1008.0)	36 ¹ / ₄ (919.0)
	480	17.0	3	1	CFRS743M13XS	C2-43	C2-35	425 (193)	62 ¹ / ₄ (1580.0)	39 ³ / ₄ (1008.0)	36 ¹ / ₄ (919.0)
	240	22.0	3	2	CFRS751M12XS	C2-218	C2-224	457 (208)	69 ⁷ / ₈ (1774.8)	47 ³ / ₈ (1203.3)	43 ⁷ / ₈ (1114.4)
	480	22.0	3	1	CFRS751M13XS	C2-225	C2-226	457 (208)	69 ⁷ / ₈ (1774.8)	47 ³ / ₈ (1203.3)	43 ⁷ / ₈ (1114.4)
	240	27.0	3	2	CFRS762D12XS	C2-218	C2-224	461 (209)	79 ³ / ₈ (2016.1)	56 ⁷ / ₈ (1444.6)	53 ³ / ₈ (1355.7)
	480	27.0	3	1	CFRS762D13XS	C2-225	C2-226	461 (209)	79 ³ / ₈ (2016.1)	56 ⁷ / ₈ (1444.6)	53 ³ / ₈ (1355.7)
	240	32.0	3	2	CFRS770M12XS	C2-218	C2-224	554 (252)	88 ³ / ₈ (2244.7)	65 ⁷ / ₈ (1673.2)	62 ³ / ₈ (1584.3)
	480	32.0	3	1	CFRS770M13XS	C2-225	C2-226	554 (252)	88 ³ / ₈ (2244.7)	65 ⁷ / ₈ (1673.2)	62 ³ / ₈ (1584.3)
	240	36.0	3	2	CFRS779M12XS	C2-218	C2-224	636 (289)	98 ³ / ₈ (2498.7)	75 ⁷ / ₈ (1927.2)	72 ³ / ₈ (1838.3)
480	36.0	3	1	CFRS779M13XS	C2-224	C2-226	636 (289)	98 ³ / ₈ (2498.7)	75 ⁷ / ₈ (1927.2)	72 ³ / ₈ (1838.3)	

③ Wired for 3-phase operation only

8 inch - 150 lb ANSI Flange

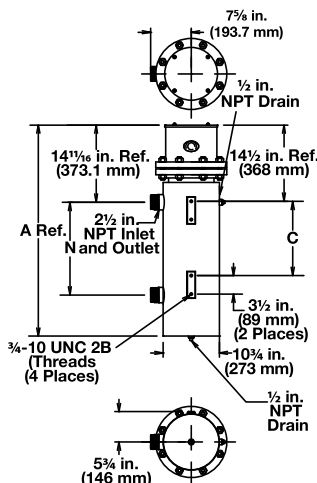

Circulation Heaters



WATROD and FIREBAR Circulation Heaters



Application: Bunker C, Asphalt and #6 Fuel Oil

- WATROD elements
- Without thermostat
- General purpose enclosure

Description	Volts	kW	Ph	# Circ.	Part Number	WATCONNECT Part Number		Ship Wt. lbs (kg)	"A" Dim. in. (mm)	"N" Dim. in. (mm)	"C" Dim. in. (mm)
						Type J T/C	Type K T/C				
10 inch - 150 lb ANSI Flange (WATROD)											
8 W/in² ③ Steel Tank 27-Steel Elements (1.3 W/cm²)	240	30.0	3	3	CFSS762E12S	C4-143	C4-142	540 (245)	91 ¹ / ₄ (2316.0)	75 ¹ / ₂ (1916.0)	82 ¹ / ₄ (2088.0)
	480	30.0	3	1	CFSS762E13S	C2-225	C2-226	540 (245)	91 ¹ / ₄ (2316.0)	75 ¹ / ₂ (1916.0)	82 ¹ / ₄ (2088.0)
	240	35.0	3	3	CFSS770N12S	C4-144	C4-145	600 (273)	99 ¹ / ₈ (2517.8)	83 ³ / ₈ (2117.7)	89 ¹³ / ₁₆ (2281.2)
	480	35.0	3	1	CFSS770N13S	C2-225	C2-226	600 (273)	99 ¹ / ₈ (2517.8)	83 ³ / ₈ (2117.7)	89 ¹³ / ₁₆ (2281.2)
	240	40.0	3	3	CFSS778N12S	C4-144	C4-145	645 (293)	106 ⁵ / ₈ (2708.3)	90 ⁷ / ₈ (2308.2)	97 ⁵ / ₁₆ (2471.7)
	480	40.0	3	1	CFSS778N13S	C2-225	C2-226	645 (293)	106 ⁵ / ₈ (2708.3)	90 ⁷ / ₈ (2308.2)	97 ⁵ / ₁₆ (2471.7)

③ Wired for 3-phase operation only

10 inch - 150 lb ANSI Flange

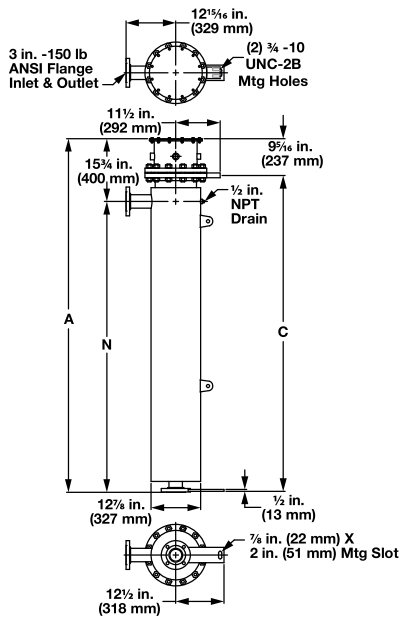

Circulation Heaters



WATROD and FIREBAR Circulation Heaters



Application: Bunker C, Asphalt and #6 Fuel Oil

- WATROD elements
- Without thermostat
- General purpose enclosure

Description	Volts	kW	Ph	# Circ.	Part Number	WATCONNECT Part Number		Ship Wt. lbs (kg)	"A" Dim. in. (mm)	"N" Dim. in. (mm)	"C" Dim. in. (mm)
						Type J T/C	Type K T/C				
12 inch - 150 lb ANSI Flange (WATROD)											
8 W/in² ③ Steel Tank 36-Steel Elements (1.3 W/cm²)	240	47.0	3	3	CFTS770L12S	C4-144	C4-145	700 (318)	99 (2515)	82 ⁷ / ₈ (2105.0)	89 ⁵ / ₈ (2277)
	480	47.0	3	2	CFTS770L13S	C2-229	C2-230	700 (318)	99 (2515)	82 ⁷ / ₈ (2105.0)	89 ⁵ / ₈ (2277)
	240	54.0	3	3	CFTS778L12S	C4-144	C4-145	750 (341)	106 ¹ / ₂ (2705)	90 ³ / ₈ (2295.5)	97 ¹ / ₈ (2467)
	480	54.0	3	2	CFTS778L13S	C2-229	C2-230	750 (341)	106 ¹ / ₂ (2705)	90 ³ / ₈ (2295.5)	97 ¹ / ₈ (2467)
14 inch - 150 lb ANSI Flange (WATROD)											
8 W/in² ③ Steel Tank 45-Steel Elements (1.3 W/cm²)	240	60.0	3	3	CFWS770J12S	C4-144	C4-145	700 (318)	98 ¹ / ₄ (2496)	82 (2081)	88 ¹¹ / ₁₆ (2253)
	480	60.0	3	3	CFWS770J13S	C4-150	C4-151	700 (318)	98 ¹ / ₄ (2496)	82 (2081)	88 ¹¹ / ₁₆ (2253)
	240	67.0	3	5	CFWS778J12S	C/F	C/F	780 (354)	105 ³ / ₄ (2686)	89 ¹ / ₂ (2272)	96 ³ / ₁₆ (2443)
	480	67.0	3	3	CFWS778J13S	C4-152	C4-153	780 (354)	105 ³ / ₄ (2686)	89 ¹ / ₂ (2272)	96 ³ / ₁₆ (2443)

C/F - Contact factory, go to www.watlow.com/en/contact-us

12 inch - 150 lb ANSI Flange

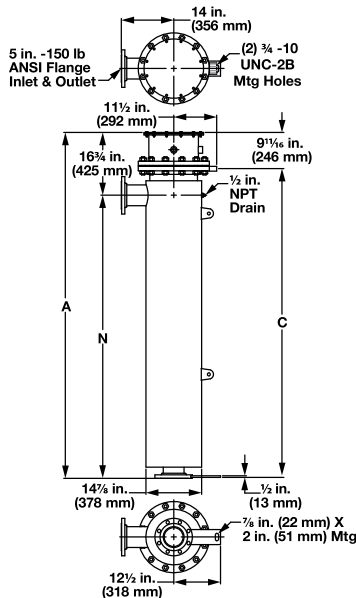

14 inch - 150 lb ANSI Flange

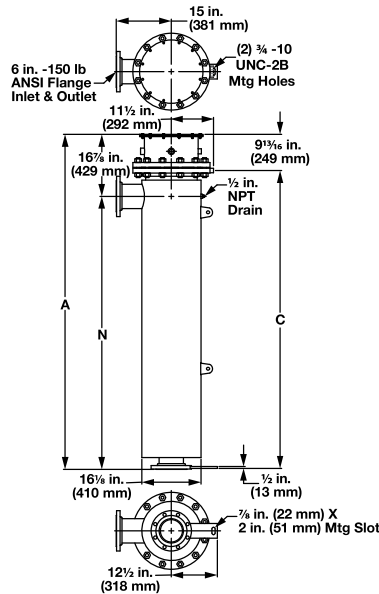

Circulation Heaters



WATROD and FIREBAR Circulation Heaters

Part Number

Stock Plug or ANSI Flange Part Number	Optional Terminal Enclosures	Optional Process Sensors	Sheath Limit Sensors

Stock Plug or ANSI Flange Part Number
<p>Note: Catalog part numbers include optional enclosures and process sensors. To order optional enclosures or sensors, substitute the appropriate suffix.</p>

Optional Terminal Enclosures
S = General purpose enclosure
W = NEMA 4 enclosure
C = Moisture/explosion resistant enclosure
<p>Note: Catalog listings include either a general purpose enclosure or NEMA 4 enclosure. Substitute enclosure options are noted.</p>

Optional Bulb and Capillary Thermostats or Thermocouple Process Sensors
2 = 30 to 250°F, (-1 to 121°C) SPST
3 = 175 to 550°F, (79 to 288°C) SPST
4 = 40 to 110°F, (-1 to 43°C) DPST
5A= 60 to 250°F, (16 to 121°C) DPST (FIREBAR)
7A= 100 to 550°F, (38 to 288°C) DPST (FIREBAR)
J = Type J process thermocouple in thermowell
K = Type K process thermocouple in thermowell
<p>Note: Thermostat part numbers are shown in the <i>Thermostat Chart</i> on page 517.</p>

Sheath Limit Sensors
HJ= Type J high-limit thermocouple, horizontal mount
TJ= Type J high-limit thermocouple, vertical/housing at top
BJ= Type J high-limit thermocouple, vertical/housing at bottom
HK= Type K high-limit thermocouple, horizontal mount
TK= Type K high-limit thermocouple, vertical/housing at top
BK= Type K high-limit thermocouple, vertical/housing at bottom
<p>Note: Heater orientation is critical to accurate sensing of limit conditions. Use the appropriate code to indicate heater mounting orientation.</p>

Example Part Number: CFONA18A10 S 5 HJ