

### Model TEC-4300 1/4 DIN Temperature Controller



**Configurable for 5 Programmable Outputs!**

Agency Approvals



#### Design Features

- \* 1/4 DIN size – 96 mm × 96 mm
- \* Fuzzy Logic PID heat and cool control
- \* PID Control – Auto-tuning on cold or warm start
- \* Short panel depth – only 2" (53 mm) required
- \* Universal programmable sensor input
- \* Heater Break Alarm using 0-50 Amp current transformer
- \* Output 2 can be programmed as cooling output only
- \* 2 optional alarms – programmable NO or NC relay
- \* Wide variety of alarm mode selections
- \* Bumpless transfer to manual mode during sensor failure
- \* Universal input power, 90-264 VAC or 11-26 VAC/VDC
- \* Power limiter output
- \* RS-485 and RS-232 data communications interface
- \* Bright 0.55" (14 mm) red LED process display 0.40" (10 mm) and green LED setpoint display stabilized with a digital filter if required
- \* Fast input sample rate (5 samples/second)
- \* Differential control
- \* "Soft-Start" ramp and dwell timer
- \* Analog input for remote setpoint and current transformer
- \* Event input for changing functions and setpoint
- \* Hardware lockout plus remote lockout protection
- \* Loop break alarm
- \* Analog retransmission
- \* DC power supply outputs
- \* Tempco's most highly featured 1/4 DIN control

Hardware Code: TEC-4300-



A Part Number based on the hardware code and any software pre-programming will be issued at time of order.

**Standard lead time is stock to 2 weeks.**

#### Power Input BOX 1

- 4 = 90-264 VAC
- 5 = 11-26 VAC / VDC
- 9 = Other

#### Signal Input – Universal, can be programmed in the field BOX 2

- 1 = Input 1 - Universal input (factory default = tc type J)  
Thermocouple: J, K, T, E, B, R, S, N, L  
RTD: PT100 DIN, PT100 JIS  
Current: 4-20 mA, 0-20 mA  
Voltage: VDC, 0-1, 0-5, 1-5, 0-10
- Input 2 - CT: 0 - 50A AC current Transformer (factory default)  
Linear Input: 0-1V, 0-5V, 1-5V, 0-10V, 0-20mA, 4-20mA
- Input 3 - Event Input
- 9 = Other

#### Output 1 BOX 3

- 1 = Relay: 2A / 240 VAC
- 2 = Pulse DC for SSR drive: 5 VDC (30 mA max)
- 3 = Isolated, 4-20 mA (default), 0-20 mA
- 4 = Isolated, VDC, 1-5 (default), 0-5, 0-1
- 5 = Isolated, VDC, 0-10
- 6 = Triac-SSR output 1A / 240 VAC
- C = Pulse DC for SSR drive: 14 VDC (40 mA max)
- 9 = Other

#### Output 2 BOX 4

- 0 = None
- 1 = Relay: 2A / 240 VAC
- 2 = Pulse DC for SSR drive: 5 VDC (30 mA max)
- 3 = Isolated, 4-20 mA (default), 0-20 mA
- 4 = Isolated VDC, 1-5 (default), 0-5, 0-1
- 5 = Isolated VDC, 0-10
- 6 = Triac-SSR output 1A / 240 VAC
- 7 = Isolated 20V @ 25 mA DC, Output Power Supply
- 8 = Isolated 12V @ 40 mA DC, Output Power Supply
- 9 = Isolated 5V @ 80 mA DC, Output Power Supply
- C = Pulse DC for SSR drive: 14 VDC (40 mA max)
- A = Other

#### Alarm 1 BOX 5

- 0 = None
- 1 = Relay: 2A/240 VAC, SPDT
- 9 = Other

#### Alarm 2 BOX 6

- 0 = None
- 1 = Relay: 2A/240 VAC, SPST
- 9 = Other

#### Communications BOX 7

- 0 = None
- 1 = RS-485 Interface
- 2 = RS-232 Interface
- 3 = Retransmission 4-20 mA (default), 0-20 mA
- 4 = Retransmission 1-5 VDC (default), 0-5 VDC
- 5 = Retransmission 0-10 VDC
- 9 = Other

**Transformer for Heater Break Alarm**  
(0-50 Amp current)  
**Part Number: TEC99999**  
Specifications on page 13-47



**Note:** Detailed information on features common to digital microprocessor-based TEC temperature controls and the complete Table of Input Range and Accuracy can be found on page 13-46.

### Power Input

**Standard:** 90 - 264 VAC, 47-63 Hz, 15 VA, 7W maximum  
**Optional:** 11 - 26 VAC / VDC, 15 VA, 7W maximum

### Signal Input

#### Input 1

**Resolution:** 18 bits **Sampling Rate:** 5 samples / second  
**Accuracy:**  $\pm 0.24\%$  of span typical  
**Maximum Rating:** -2 VDC minimum, 12 VDC maximum (1 minute for mA input)  
**Temperature Effect:**  $\pm 1.5 \mu V / ^\circ C$  for all inputs except mA input  $\pm 3.0 \mu V / ^\circ C$  for mA input

**Sensor Lead Resistance Effect:** T/C:  $0.2 \mu V / \text{ohm}$   
 3-wire RTD:  $2.6^\circ C / \text{ohm}$  of resistance difference of two leads  
**Burn-out Current:** 200nA

**Common Mode Rejection Ratio (CMRR):** 120 dB  
**Normal Mode Rejection Ratio (NMRR):** 55 dB

**Sensor Break Detection:** Sensor open for TC, RTD and mV inputs; sensor short for RTD input; below 1 mA for 4-20 mA input; below 0.25V for 1-5V input; unavailable for other inputs

**Sensor Break Response Time:** Within 4 seconds for TC, RTD and mV inputs; 0.1 second for 4-20 mA and 1-5 V inputs

#### Input 2

**Resolution:** 18 bits **Sampling Rate:** 1.66 times per second  
**Sensor Break Response Time:** 0.5 second  
**Types:** **Current Transducer:** 0 to 50 Amp  
**mA:** -3 to 27 mA **V:** -1.3 to 11.5 VDC

#### Input 3

**Event Input Functions:** Select 2nd setpoint, and/or PID, disable output 1 and/or output 2, remote lockout

### Output 1 or Output 2

**Relay Rating:** 240 VAC, 2 Amp  
**Pulsed Voltage:** Source voltage 5V, Current limiting resistance 66 $\Omega$

#### Linear Output — Characteristics

Type	Tolerance	Zero Tolerance	Span Capacity	Load
4-20 mA		3.6-4.0 mA	20-21 mA	500 $\Omega$ max
0-20 mA		0 mA	20-21 mA	500 $\Omega$ max
0-5 VDC		0 VDC	5-5.25 VDC	10 K $\Omega$ min
1-5 VDC		0.9-1.0 VDC	5-5.25 VDC	10 K $\Omega$ min
0-10 VDC		0 VDC	10-10.5 VDC	10 K $\Omega$ min

**Resolution:** 15 bit analog to digital converter

**Isolation Breakdown Voltage:** 1000 VAC

#### Solid State Relay (Triac) Output

**Rating:** 1A / 240 VAC **Inrush Current:** 20A for 1 cycle  
**Min. Load Current:** 50 mA rms  
**Max. Off-state Leakage:** 3 mA rms  
**Max. On-state Voltage:** 1.5 VAC rms  
**Insulation Resistance:** 1000 Megohms minimum at 500 VDC  
**Dielectric Strength:** 2500 VAC for 1 minute

### Rear Terminal Connections

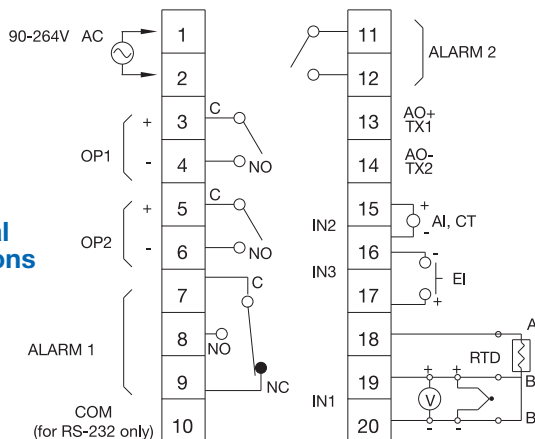

### Alarm 1 / Alarm 2

**Relay:** 2 Amp, 240 VAC **Alarm 1:** SPDT **Alarm 2:** SPST (NO)

#### Alarm Functions:

Dwell timer PV1-PV2 High / Low Alarm  
 Deviation Band High / Low Alarm Loop Break Alarm  
 PV2 High / Low Alarm Sensor Break Alarm

**Alarm Mode:** Normal, Latching, Hold, Latching / Hold

**Dwell Timer:** 0 - 6553.5 minutes

### Data Communications

**Interface:** RS-232 (1 unit), RS-485 (up to 247 units)

**Protocol:** Modbus Protocol – RTU mode

### User Interface

**Dual 4-digit LED Display:** 0.55" (14 mm) Red Process Display

**Keypad:** 3 keys 0.40" (10 mm) Green Setpoint Display

**Programming Port:** For automatic setup, calibration and testing

### Control Mode

**Output 1:** Reverse (heating) or direct (cooling) action

**Output 2:** PID cooling control, cooling P band 255% of PB

**On-Off:** 0.1 - 100.0°F hysteresis control (P band = 0)

**P or PD:** 0 - 100.0% offset adjustment

**PID:** Fuzzy logic modified

**Proportional band:** 0.1 - 932°F (500°C)

**Integral:** 0 - 1000 seconds **Derivative:** 0 - 360 seconds

**Cycle Time:** 0.1 - 100 seconds

**Manual Control:** Heat (MV1) and Cool (MV2)

**Auto-tuning:** Cold start and warm start

**Failure Mode:** Auto-transfer to manual mode with sensor break or A-D converter damage

**Ramping Control:** 0 - 900°F/min or 0 - 900°F/hr ramp rate

**Power Limit:** 0 - 100% for output 1 and output 2

**Remote Setpoint:** Programmable range for voltage or current input

**Digital Filter:** Time constant: settable from 0.2 to 60 seconds

### Analog Retransmission

**Analog Retransmission Functions:** PV1, PV2, PV1-PV2, PV2-PV1, Setpoint, MV1, MV2, PV-SV deviation value

**Output Signal:** 4-20 / 0-20 mA, 0-1, 0-5, 1-5, 0-10 VDC

**Accuracy:**  $\pm 0.05\%$  of span,  $\pm 0.0025\%$  / °C

### Environmental and Physical

**Operating Temperature:** 14 to 122°F (-10 to 50°C)

**Humidity:** 0 to 90% RH, non-condensing

**Dielectric Strength:** 2000 VAC, 50/60 Hz for 1 minute

**Dimensions:** 3-3/4 x 3-3/4 x 2-9/16" (96 x 96 x 65 mm) HxWxD  
 Depth behind panel: 2" (53 mm)

**Panel Cutout:** 3-5/8" x 3-5/8" (92 x 92 mm) HxW

**Weight:** 0.56 lb. (255 grams)

### Approval Standards

**Safety:** UL873, CSA C22.2 No. 24-93  
 EN61010-1 (IEC1010-1)

**Protective Class:** IP 20 housing & terminals with protective covers

**EMC:** EN61326

### Stock and Common Part Numbers

(Power Input: 90-264 VAC, no alarm 2, no data com)

Part Number	Signal Input	Out 1	Out 2	Alarm 1
TEC55001	tc-J	relay	none	relay
TEC55002	tc-J	relay	relay	none
TEC55003	tc-J	relay	relay	relay
TEC55004	tc-J	4-20 mA	none	none
TEC55005	tc-J	4-20 mA	none	relay
TEC55006	tc-J	DC pulse	none	none
TEC55007	tc-J	DC pulse	none	relay