

Model TEC-4100 1/4 DIN Temperature Controller



The TEC-4100 is also available with a black faceplate.

Design Features

- * 1/4 DIN size – 96 mm × 96 mm
- * Fuzzy Logic PID heat and cool control
- * PID Control – Auto-tuning on cold or warm start
- * Short panel depth – only 2" (53 mm) required
- * Universal programmable sensor input
- * Highly versatile – 6 types of inputs available
- * Output 2 can be used for cooling function
- * Universal input power— 90-250 VAC or 11-26 VAC/VDC
- * Optional NEMA 4X/IP65 front panel
- * Bumpless transfer to manual mode during sensor failure
- * Wide variety of alarm mode selections
- * Optional RS-232 or RS-485 communications interface
- * Bright 0.55" (14 mm) red LED process display and 0.40" (10 mm) green LED setpoint display
- * High performance at a low price

Configurable for 4 Programmable Outputs and NEMA 4X/IP65 Front Panel!

Agency Approvals



Power Input BOX 1

- 4 = 90-250 VAC
- 5 = 11-26 VAC / VDC
- 9 = Other

Hardware Code: TEC-4100-

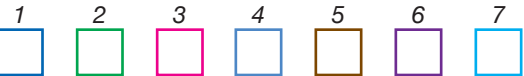

A Part Number based on the hardware code and any software pre-programming will be issued at time of order.

Standard lead time is stock to 2 weeks.

Signal Input — Universal, can be programmed in the field for item 5 or 6 BOX 2

- 5 = Thermocouple: *J, K, T, E, B, R, S, N, L
0-60mV
- 6 = RTD: *PT100 DIN, PT100 JIS
- 7 = 0-1 VDC
- 8 = *0-5, 1-5 VDC
- A = 0-10 VDC
- B = *4-20, 0-20 mA
- 9 = Other * indicates default value

Alarm BOX 5

- 0 = None
- 1 = Relay: 2A / 240 VAC, SPDT
- 9 = Other

Output 1 BOX 3

- 1 = Relay: 2A / 240 VAC
- 2 = Pulse DC for SSR drive: 5 VDC (30 mA max)
- 3 = Isolated, 4-20 mA (default), 0-20 mA
- 4 = Isolated, VDC, 1-5 (default), 0-5, 0-1
- 5 = Isolated, VDC, 0-10
- 6 = Triac-SSR output 1A / 240 VAC
- C = Pulse DC for SSR drive: 14 VDC (40 mA max)
- 9 = Other

Communication BOX 6

- 0 = None
- 1 = RS-485 Interface
- 2 = RS-232 Interface
- 3 = Retransmission 4-20 mA (default), 0-20 mA
- 4 = Retransmission 1-5 VDC (default), 0-5 VDC
- 5 = Retransmission 0-10 VDC
- 9 = Other

Output 2 BOX 4

- 0 = None
- 1 = Relay: 2A / 240 VAC
- 2 = Pulse DC for SSR drive: 5 VDC (30 mA max)
- 3 = Isolated, 4-20 mA (default), 0-20 mA
- 4 = Isolated VDC, 1-5 (default), 0-5, 0-1
- 5 = Isolated VDC, 0-10
- 6 = Triac-SSR output 1A / 240 VAC
- 7 = Isolated 20V @ 25 mA DC, Output Power Supply
- 8 = Isolated 12V @ 40 mA DC, Output Power Supply
- 9 = Isolated 5V @ 80 mA DC, Output Power Supply
- C = Pulse DC for SSR drive: 14 VDC (40 mA max)
- A = Other

NEMA 4X / IP65 BOX 7

- 0 = No
- 1 = Yes



Note: Detailed information on features common to digital microprocessor-based TEC temperature controls and the complete Table of Input Range and Accuracy can be found on page 13-46.

Power Input

Standard: 90 - 250 VAC, 47-63 Hz, 10 VA, 5W maximum
Optional: 11 - 26 VAC / VDC, 10 VA, 5W maximum

Signal Input

Resolution: 18 bits **Sampling Rate:** 5 samples / second
Accuracy: $\pm 0.24\%$ of span typical
Maximum Rating: -2 VDC minimum, 12 VDC maximum (1 minute for mA input)

Temperature Effect: $\pm 1.5 \mu\text{V} / ^\circ\text{C}$ for all inputs except mA input
 $\pm 3.0 \mu\text{V} / ^\circ\text{C}$ for mA input

Sensor Lead Resistance Effect: T/C: $0.2 \mu\text{V}/\text{ohm}$
 3-wire RTD: $2.6^\circ\text{C}/\text{ohm}$ of resistance difference of two leads

Burn-out Current: 200nA

Common Mode Rejection Ratio (CMRR): 120 dB

Normal Mode Rejection Ratio (NMRR): 55 dB

Sensor Break Detection: Sensor open for TC, RTD and mV inputs; sensor short for RTD input; below 1 mA for 4-20 mA input; below 0.25V for 1-5V input; unavailable for other inputs

Sensor Break Response Time: Within 4 seconds for TC, RTD and mV inputs; 0.1 second for 4-20 mA and 1-5 V inputs

Output 1 / Output 2

Relay Rating: 240 VAC, 2 Amp

Pulsed Voltage: Source voltage 5V, Current limiting resistance 66 Ω

Linear Output — Characteristics

Type	Tolerance	Zero Tolerance	Span Capacity	Load
4-20 mA		3.6-4.0 mA	20-21 mA	500 Ω max
0-20 mA		0 mA	20-21 mA	500 Ω max
0-5 VDC		0 VDC	5-5.25 VDC	10 K Ω min
1-5 VDC		0.9-1.0 VDC	5-5.25 VDC	10 K Ω min
0-10 VDC		0 VDC	10-10.5 VDC	10 K Ω min

Resolution: 15 bit analog to digital converter

Output Regulation: 0.02% for full load change

Output Settling Time: 0.1 sec. (stable to 99.9%)

Isolation Breakdown Voltage: 1000 VAC

Temperature Effect: $\pm 0.01\%$ of span/ $^\circ\text{C}$

Solid State Relay (Triac) Output

Rating: 1A / 240 VAC

Inrush Current: 20A for 1 cycle

Min. Load Current: 50 mA rms

Max. Off-state Leakage: 3 mA rms

Max. On-state Voltage: 1.5 VAC rms

Insulation Resistance: 1000 Megohms minimum at 500 VDC

Dielectric Strength: 2500 VAC for 1 minute

Rear Terminal Connections

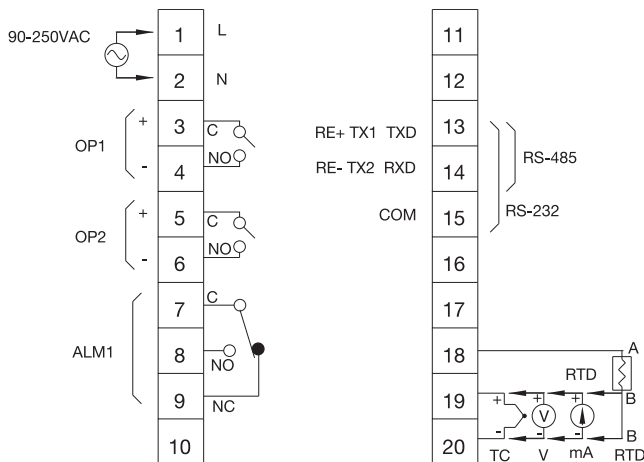

Alarm 1 — Programmable

Alarm 1 Relay: Form A, (NO)
 Maximum rating: 240 VAC, 2 Amp

Alarm Functions: Dwell timer
 Deviation High / Low Alarm
 Deviation Band High / Low Alarm
 Process High / Low Alarm
 Sensor Break Alarm

Alarm Mode: Normal, Latching, Hold, Latching / Hold

Dwell Timer: 0 - 4553.6 minutes

Data Communications

Interface: RS-232 (1 unit), RS-485 (up to 247 units)

Protocol: Modbus Protocol – RTU mode

Address: 1-247

Baud Rate: 0.3 - 38.4 Kbits/sec

Data Bits: 7 or 8 bits

Parity Bit: None, Even or Odd

Stop Bit: 1 or 2 bits

Communication Buffer: 160 bytes

User Interface

Dual 4-digit LED Display: 0.55" (14 mm) Red Process
 0.40" (10 mm) Green Setpoint

Keypad: 4 keys

Programming Port: For automatic setup, calibration and testing

Control Mode

Output 1: Reverse (heating) or direct (cooling) action

Output 2: PID cooling control, cooling P band 50-300% of PB

On-Off: 0.1 - 90.0 $^\circ\text{F}$ hysteresis control (P band = 0)

P or PD: 0 - 100.0% offset adjustment

PID: Fuzzy logic modified

Proportional band: 0.1 - 900 $^\circ\text{F}$

Integral time: 0 - 1000 seconds

Derivative time: 0 - 360 seconds

Cycle Time: 0.1 - 90 seconds

Manual Control: Heat (MV1) and Cool (MV2)

Auto-tuning: Cold start and warm start

Failure Mode: Auto-transfer to manual mode with sensor break or A-D converter damage

Ramping Control: 0 - 900 $^\circ\text{F}/\text{min}$ or 0 - 900 $^\circ\text{F}/\text{hr}$ ramp rate

Environmental and Physical

Operating Temperature: 14 to 122 $^\circ\text{F}$ (-10 to 50 $^\circ\text{C}$)

Storage Temperature: -40 to 140 $^\circ\text{F}$ (-40 to 60 $^\circ\text{C}$)

Humidity: 0 to 90% RH, non-condensing

Dielectric Strength: 2000 VAC, 50/60 Hz for 1 minute

Dimensions: 3-3/4 x 3-3/4 x 2-9/16" (96 x 96 x 65 mm) HxWxD
 Depth behind panel: 2" (53 mm)

Panel Cutout: 3-5/8" x 3-5/8" (92 x 92 mm) HxW

Weight: 0.55 lb. (250 grams)

Approval Standards

Safety Standard: UL61010C-1
 CSA C22.2 No. 24-93
 EN61010-1 (IEC1010-1)

Protective Class: IP 50 front panel standard, all indoor use.

NEMA 4X/IP65 front panel if specified.

IP 20 housing and terminals with protective cover.

EMC: EN61326

Stock and Common Part Numbers

(Power Input: 90-250 VAC, no data com, no NEMA 4X)

Part Number	Input	Out 1	Out 2	Alarm
TEC56001	tc	relay	none	relay
TEC56002	tc	relay	none	none
TEC56003	tc	4-20 mA	none	none
TEC56004	tc	dc pulse	none	none
TEC56005	RTD	relay	none	none
TEC56006	RTD	DC pulse	none	none
TEC56007	RTD	DC pulse	relay	none
TEC56008	RTD	DC pulse	none	relay