



# CHROMALOX

*Advanced Thermal Technologies*

## MiniMax

### User's Manual



[www.chromalox.com](http://www.chromalox.com)  
800-443-2640

© 2014 Chromalox, Inc.

P/N 0037-75433

Thank you for choosing the Chromalox® MiniMax™ - a complete power control solution with industry-best price and performance.

For more than 80 years, customers have relied on Chromalox for the utmost in quality and innovative solutions for industrial heating applications. Chromalox manufactures the world's largest and broadest line of electric heat and control products.

The MiniMax Series SCR Controllers provide the best control for applications where consistent heater/process temperature is critical or where fine resolution of power is required.

**Common MiniMax features include:**

- 120 - 575 Vac @ 30 - 75 Amps
- Isolated Control Circuit
- Easy Customer Interface
- Remote Shutdown
- Compact Size and Construction
- dv/dt Transient Voltage Protection
- MOV Protection

**Features for the MiniMax 1, 2, and 3 include:**

- Zero Crossover Firing
- Isolated Control Circuit
  - On/Off Control Inputs:
    - 120 thru 240 Vac
    - 5 - 32 Vdc
    - Dry Contact Closure
  - Proportional (DOT Firing) Inputs:
    - 4 - 20 mA, 0-5 Vdc, 1 - 5 Vdc, 0 - 10 Vdc
    - Remote Manual Adjust (Optional)
    - Remote Auto/Manual Switch (Optional)
- Electronically Protected with Temperature Warning and Shutdown System
- Single- or Three-Cycle Resolution (Jumper Selectable)
- Shorted SCR Detection (Optional)

**Features for the MiniMax 1P include:**

- Phase Angle Firing
- Isolated Control Circuit Inputs
  - 0 - 5 mA, 0 - 20 mA
  - 0 - 50 mA, 1 - 5 mA
  - 4 - 20 mA, 10 - 50 mA
  - 0 - 5 Vdc, 0 - 10 Vdc
- Optional Current Limit
- Soft Start
- Line Voltage Compensation
- Zero & Gain Adjustments
- Built-In Manual Adjustment
- Current Limit Adjustment (Optional)

If you have application questions, refer to the Engineering Resource section of our website at [www.chromalox.com](http://www.chromalox.com) to find the answer you're looking for, or call one of our application engineers at 1-888-996-9258 for personal assistance.

## Table of Contents

Section	Topic	Page
1.....	Important Safeguards.....	3
2.....	Description .....	4
3.....	Before You Install.....	5
4.....	Installation .....	6
4.1.....	Mounting.....	6
4.2.....	Wiring.....	8
4.2.1.....	Power/Load Wiring .....	8
4.2.2.....	Instrument Power .....	11
4.2.3.....	Grounding .....	11
4.2.4.....	Command Signal Wiring.....	11
4.2.5.....	Calibration .....	17
5.....	Specifications .....	18
6.....	Maintenance .....	19
7.....	Troubleshooting .....	20
8.....	Parts and Accessories.....	21
9.....	Warranty and Return Information .....	22
10.....	EC Declaration of Conformity.....	27

# 1 Important Safeguards

Please read all instructions before installing and operating your MiniMax™.

To avoid electrical shock or injury, always remove power before servicing a circuit.

Personnel working with or near high voltages should be familiar with modern methods of resuscitation. Contact an area supervisor or safety personnel for more information.

Throughout the MiniMax User Manual, the safety alert and the international electric shock/electrocution symbols will alert you to potential hazards. Safety precautions should always be followed to reduce the risk of personal injury to persons from fire and electrical shock hazards.



Safety Alert Symbol



International Shock/Electrocution Symbol

Each safety message is preceded by a safety alert symbol  and one of three words: DANGER, WARNING, or CAUTION.

These mean:



You WILL be killed or seriously hurt if you do not follow instructions.



You CAN be killed or seriously hurt if you do not follow instructions.



You CAN be hurt if you do not follow instructions.

Damage Prevention Messages:

You will see other IMPORTANT messages that are preceded by the word **CAUTION** that are intended to help prevent damage to the MiniMax™ or other equipment. Note that Damage Prevention Messages are NOT accompanied by the Safety Alert Symbol.

## 2 Description

### MiniMax 1, 2, and 3

The Chromalox MiniMax 1, 2, and 3 controllers are highly versatile SCR Power Paks with optional plug-in proportional firing and shorted SCR detection boards. Firing modes include On/Off and DOT proportional zero voltage switching. Chromalox exclusive DOT (Demand Oriented Transfer) firing technique switches the fewest number of cycles to provide the most precise zero crossover control. At 50% output, the unit's output alternates between one cycle "On" and one cycle "Off." At 51%, the output continues with one cycle "On," one cycle "Off," and gradually integrates one extra "On" cycle for the additional 1%. This DOT fired technique also minimizes temperature overshoot, temperature fluctuations and helps extend the load's element life due to reduced thermal shock.

The power SCR assemblies consist of one, two, or three pairs of SCRs connected back to back (with an optional semiconductor fuse), RC Snubber, and MOV protection. The firing circuit is based on a common On/Off control board with plug and play Shorted SCR and DOT fired plug-in boards. Diagnostic indicators are included. Plug-in terminal blocks for easy customer interface are also provided.

### MiniMax 1P

The Chromalox MiniMax 1P utilizes Single Phase, Phase Angle firing to modulate power to an inductive or resistive load. Phase Angle control has the advantage of proportioning every cycle thereby providing very fine resolution of power. Fast responding loads in which the resistance changes as a function of temperature require Phase Angle control. The MiniMax 1P offers a Soft Start feature that assures that the load power is gradually increased from zero to the value set by the command signal in the event of a power interruption. In addition, optional Current Limit is used to protect the load, SCR controller and the total system from large surge currents that could occur at start-up.

† This can be set to three cycles 'On' / three cycles 'Off' (see section on installation options).

# 3 Before You Install

Immediately after receiving your MiniMax 1, 2, 3, or 1P Series Controller, visually inspect the shipment packaging and record any damage on the shipping documents. Unpack the controller and carefully inspect for obvious damage due to shipment. If any damage has occurred, YOU must file a claim with the carrier company, since the carrier company will not accept a claim from the shipper (Chromalox).

Be sure to check the model number and verify that you have received the correct Model of controller.

If the controller is not installed and placed into operation immediately, it should be stored in a cool, dry environment. Temperature extremes and excessive moisture can damage the controller.

Before choosing a location in which to mount your MiniMax, please consider the following:

## Temperature

When mounting the SCR unit in a control panel, attention should be paid to the enclosure temperature. The SCR is rated to perform at its nameplate current rating in temperatures up to 50°C (122°F). Ensure that adequate ventilation is provided or some other method of maintaining the correct cabinet temperature is used.

## Cleanliness

Careful attention must be paid in areas subjected to airborne particles. The efficiency of the heat sinks relies on their conducting surfaces being maintained in a clean manner. (See the Maintenance Section.)

## Dampness

High humidity or hosing down a unit should be avoided.

## Clearance

Choose a location that will provide adequate spacing around the unit when mounted. This will ensure proper air flow necessary to cool the device.

	<b>WARNING</b>
	<b>Hazardous Voltage:</b> Disconnect and lockout power before installing or servicing. Failure to comply could result in personal injury or equipment damage.

# 4 Installation

Please read all information in this section before beginning the installation of your MiniMax.

Installation of the MiniMax requires three steps:

1. Mounting
2. Power wiring
3. 120 or 230 Vac 50/60hz for instrument power. See 4.2.4, pg. 11.

## 4.1 - Step 1: Mounting

Before mounting your MiniMax, please read the section titled "Before You Install" on page 5 for a description of an ideal environment for the unit's operation.

The space required for mounting the MiniMax Power Pak depends upon the model. The table below refers to the figures on the following pages. These figures illustrate the dimensions and mounting holes for the various MiniMax Power Pak models. Please refer to these figures before mounting your unit.

Figure	Model
1.....	MiniMax 1 – 30 & 50 Amp Mounting Base
1.....	MiniMax 1P – 30 & 50 Amp Mounting Base
2.....	MiniMax 1 – 75 Amp Mounting Base
2.....	MiniMax 1P – 75 Amp Mounting Base
3.....	MiniMax 2 – 30 & 50 Amp Mounting Base
4.....	MiniMax 2 – 75 Amp Mounting Base
5.....	MiniMax 3 – 30, 50 & 75 Amp Mounting Base

**IMPORTANT:** Please note that the figures on the following pages are **not drawn to the same scale.**

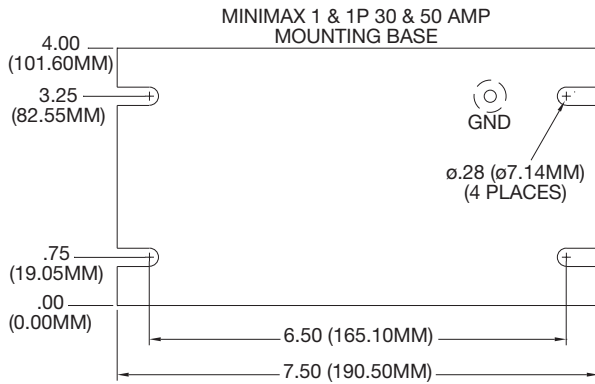

**Figure 1**

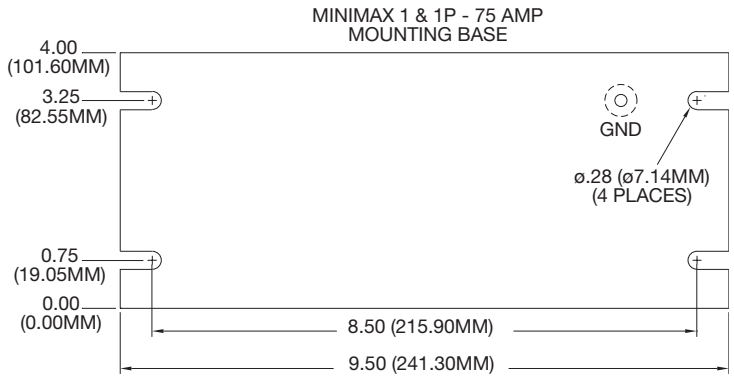

**Figure 2**

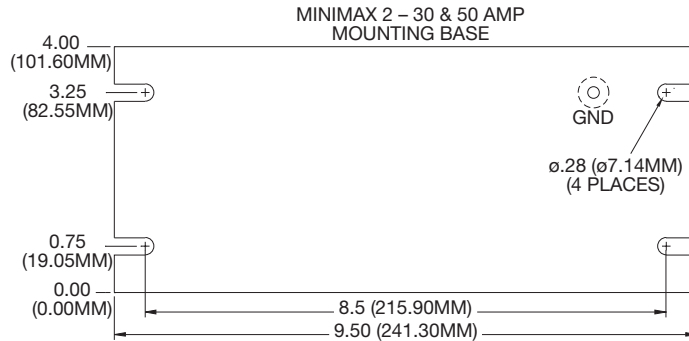

**Figure 3**

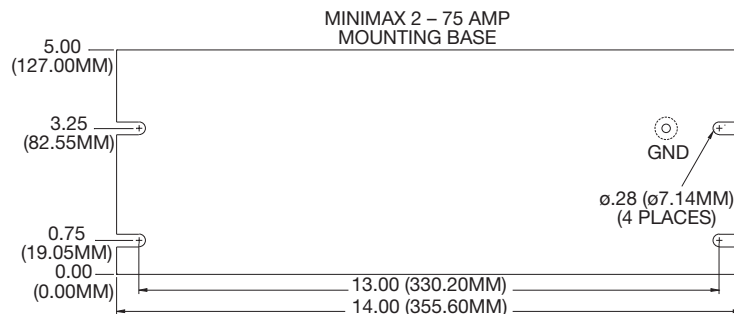

**Figure 4**

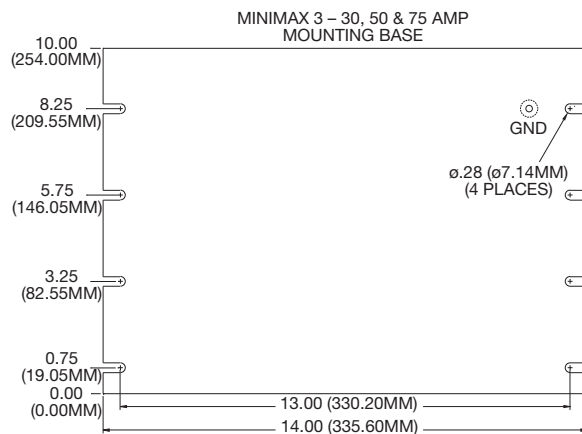



**Figure 5**



## 4.2 - Step 2: Wiring

Careful attention must be paid when attaching the wiring to the MiniMax to ensure proper and safe operation. This section contains detailed information on how to connect the power, resistive load, ground, and command signal wiring.

	 <b>WARNING</b>
	<b>Hazardous Voltage:</b> Only qualified personnel should perform electrical wiring for the MiniMax Power Paks. LETHALLY HIGH VOLTAGES are associated with this equipment and are dangerous if improperly installed.

**IMPORTANT:** Select installation wiring that is in accordance with the National Electrical Code and any local standards that may be applicable.

### 4.2.1 - Power/Load Wiring

The following illustrations depict how to connect the MiniMax to a resistive or inductive load. Make sure you refer to the correct illustration for the MiniMax series you have purchased.

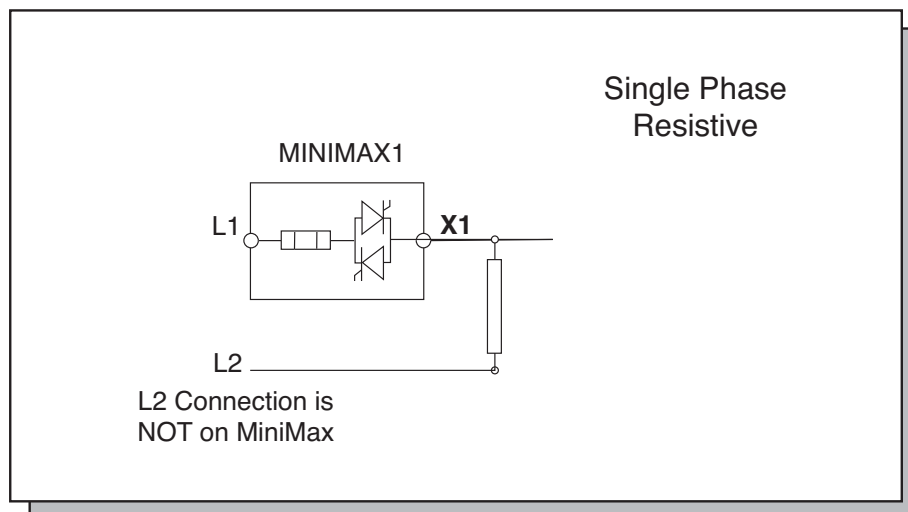

**MiniMax 2**

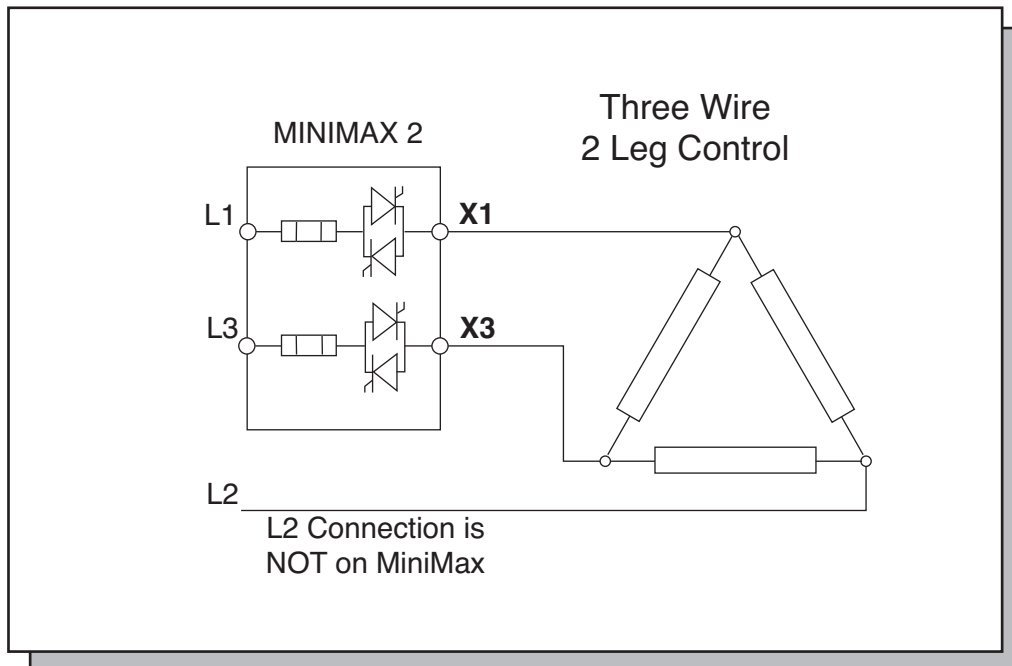

**MiniMax 3**

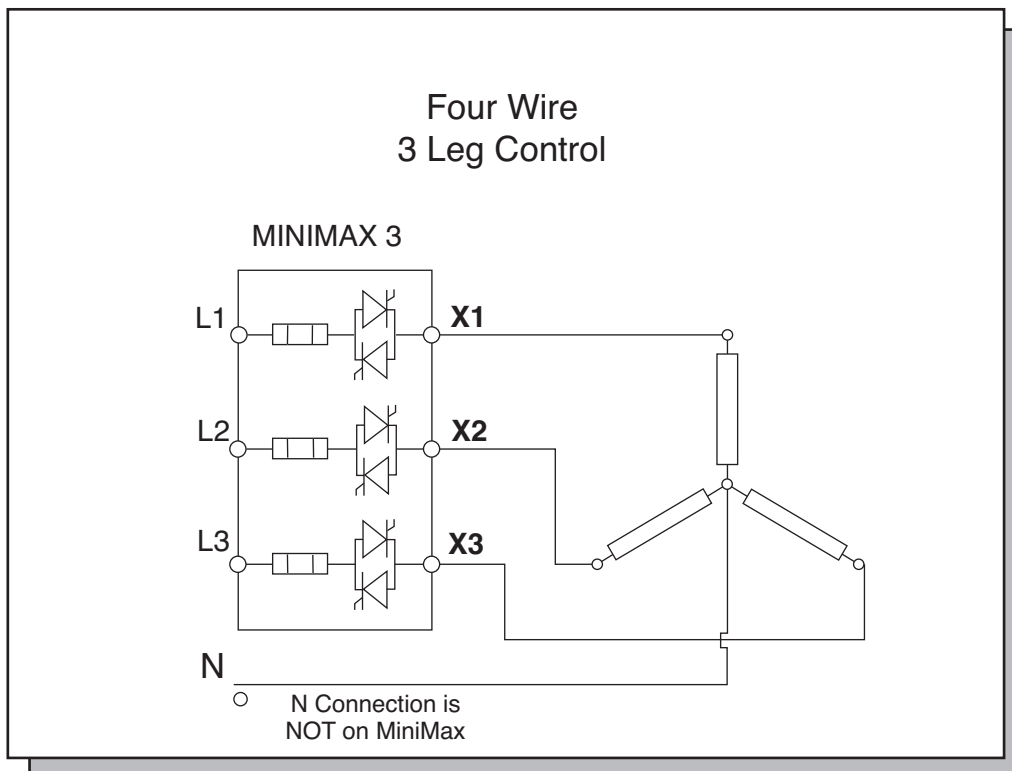

**CAUTION**

**IMPORTANT:** The I<sup>2</sup>t fuses installed on the SCR are designed to protect the SCR from faults on the load connection side. They are **NOT** intended to provide wire protection.

### MiniMax 3

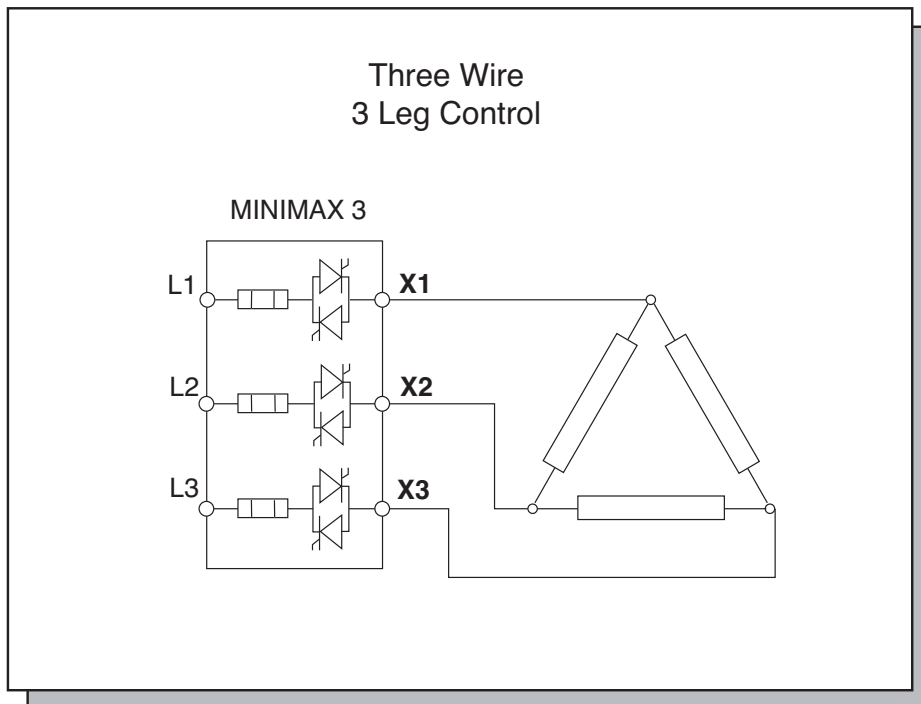

### MiniMax 1P

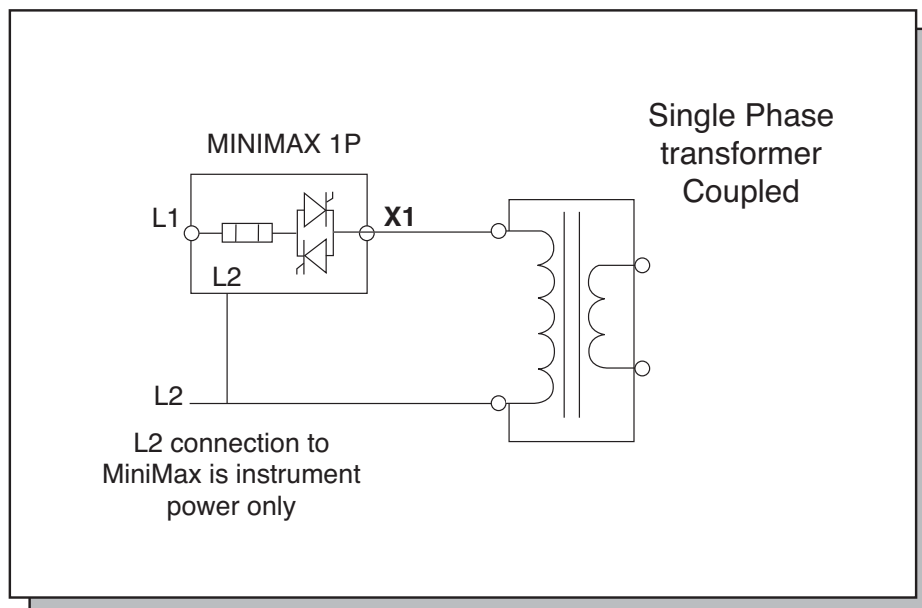

### CAUTION



**IMPORTANT:** The I<sup>2</sup>t fuses installed on the SCR are designed to protect the SCR from faults on the load connection side. They are **NOT** intended to provide wire protection.

#### 4.2.2 - Instrument Power

<b>IMPORTANT</b>
<p><b>MiniMax requires 120 or 230 Vac 50/60Hz for instrument power. This voltage supplies power for the control circuits, fans, high temperature warning indicator, and shorted SCR Indicators (see Fig. 1 on page 15).</b></p> <p><b>This supply is fused on the main circuit board.</b></p>

#### 4.2.3 - Grounding

Chassis is provided with a stud for ground connections.

	 <b>WARNING</b>
	<p><b>Hazardous Voltage:</b> This Electrical Equipment must be installed by a qualified person and effectively grounded in accordance to the National Electric Code and local codes.</p>

#### 4.2.4 - Command Signal Wiring

Please refer to the figures on page 12 for illustrations of the 6-, 8-, and 10-pin input terminals.

#### MiniMax 1, 2, and 3

##### **On/Off Control Signals**

**AC Input** – The 120 thru 230 Vac signal lines are connected to terminal J1 - 7 & 8 (see Fig. 9 on page 21). An input voltage of 120 to 230 Vac turns the power On. The turn OFF voltage is 0 Vac.

**DC Input** – The 5 - 32 Vdc signal lines are connected to terminal J3 - 1 & 4 (see Fig. 10 on page 21). An input voltage of 5 to 32 Vdc turns the power On. The turn OFF voltage is 0 Vdc.

**Contact Closure Input** – The dry contact signal lines are connected to terminal J3 - 1 & 2 (see Fig. 11 on page 21). A closed contact turns the power On. The turn OFF voltage is an open contact.

##### **Process Analog Control Signals**

MiniMax 1, 2, and 3 have been factory calibrated. These units accept 0 - 5, 1 - 5, 0 - 10 Vdc, and 4 - 20 mA input signals that are connected to Terminal Block J2. The following signals are connected to:

- 0 - 5 Vdc: Terminal J2 - 9(+) & 7(-) (see Fig. 7 on page 21)
- 1 - 5 Vdc: Terminal J2 - 5(+) & 7(-) (see Fig. 5 on page 21)
- 0 - 10 Vdc: Terminal J2 - 10(+) & 7(-) (see Fig. 8 on page 21)
- 4 - 20 mA: Terminal J2 - 6(+) & 7(-) (see Fig. 6 on page 21)

### Auto/Manual Input

The MiniMax 1, 2, and 3 can be wired to make it possible to select an input from either a temperature process controller or a manual input potentiometer. A switch is used to select between the input from a 1K potentiometer and a linear control input (see Fig. 4 on page 15). The unit is shipped with a jumper from terminals 2 and 3 of terminal block J2 (see illustration 3). Remove jumper to install auto/manual input.

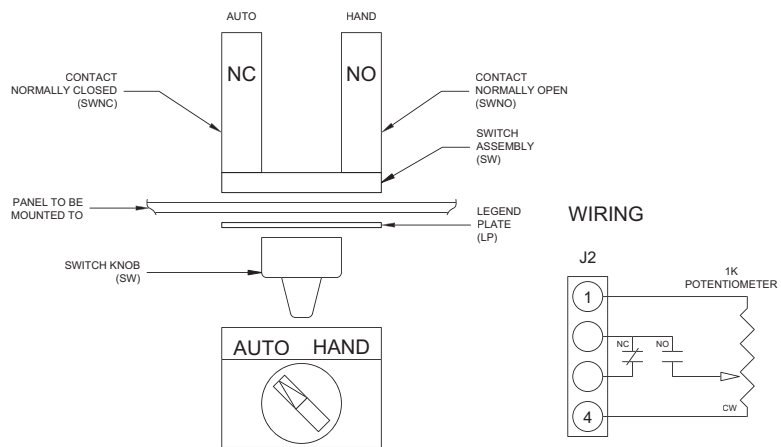

**Illustration 3**

**CAUTION**

**IMPORTANT:** When enabling the Auto/Manual Input, the jumper from terminals 2 and 3 of terminal block J2 must be removed.

### Demand Indicator

The LED demand indicator is located on the main PC board and is viewable through the cover. With the On/Off control option, the indicator will display steady “on” and steady “off”. With the DOT Firing option, the indicator will display the rapid firing sequence.

### SCR Control Board

The Basic control board provides the following functions:

The low voltage dc to operate the circuitry:

A switching regulator circuit converts the instrument power voltage to +12Vdc.

The power distribution for the cooling fans:

The incoming instrument power is fused and then routed to the fan power terminals.

The signal condition for the on/off input and analog inputs:

The 120 to 240 on/off input is isolated by an opto-coupler. The dc and contact closure inputs are buffered by the circuitry. Amplifiers convert the analog inputs and the potentiometer input to a signal level compatible with the optional proportional firing board. The plug-in receptacle for the optional proportional board allows for an easy upgrade to proportional control.

The drive signal to the SCR trigger boards:

The temperature alarm:

The heat sink temperature is derived from a solid state sensor mounted on the heat sink. This is then compared to two set points. The first alarm is a warning and activates the externally connected device. This allows time to correct the problem before the second alarm inhibits the firing circuit.

The Shorted SCR Alarm:

The plug-in receptacle for the shorted SCR board is located on this board. Signals from the SCR are routed to the option board. When a short is detected the externally connected device output is activated.

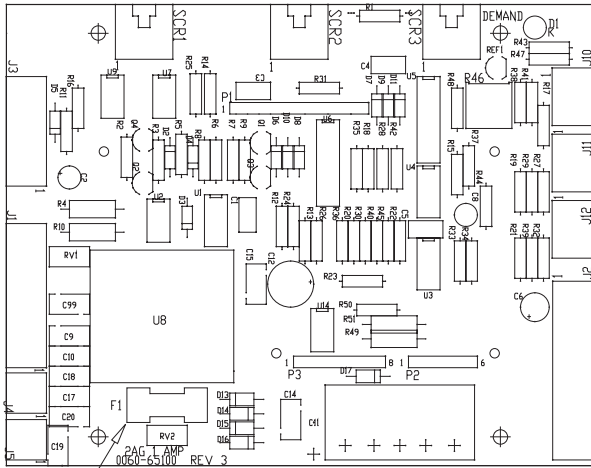

2AMP (2AG)  
CHROMALOX P/N 0024-01097  
LITTLEFUSE P/N 225 002

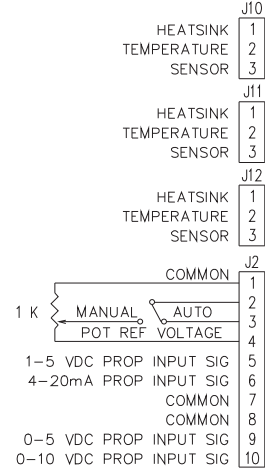
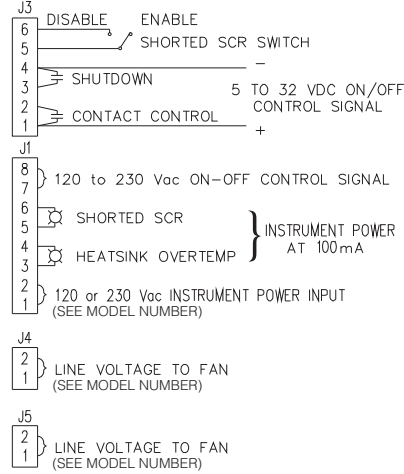

**Proportional DOT Firing Board**

Chromalox's exclusive DOT (Demand Oriented Transfer) firing technique switches the fewest number of cycles to provide the most precise zero crossover control. At 50% output, the unit's output alternates between one cycle "On" and one cycle "Off." At 51%, the output continues with one cycle "On," one cycle "Off," and gradually integrates one extra "On" cycle for the additional 1%.

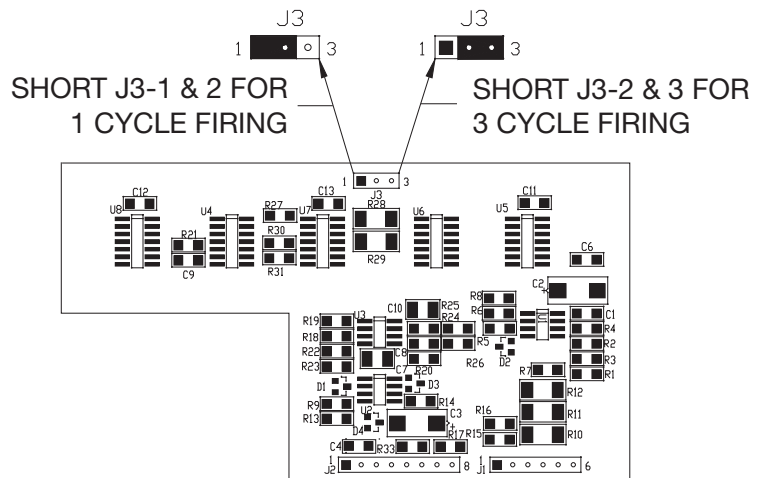

Unit shipped for 3 cycle operation

**Remote Shutdown**

When it is necessary to disable the output, connect a dry contact between J3 - 3 & 4 (see Fig. 12 on page 15). When it is closed, the power control will shut OFF.

**CAUTION**

**IMPORTANT:** This shutdown overrides the control input only. It will NOT protect against faulted or damaged SCRs.

### Shorted SCR Detection (optional)

This option provides a means of alerting an operator to a problem with the system. An external indicating lamp or relay can be connected to J1 - 5 & 6 (see Fig. 2 on page 15). This indicator must be rated for the instrument power applied to J1 - 1 & 2. Three diagnostic LEDs show which SCR pair is faulted. These lights are synchronized with the demand indicator and can only indicate while the demand is active. Shorting J3 - 5 & 6 can disable the output at J1 - 5 & 6. The alarm can be selected as latching or non-latching.

A latching alarm means that if the alarm activates and the system subsequently returns to normal, the alarm will remain latched until a reset button (external switch – customer provided) is pressed. A non-latching alarm resets automatically.

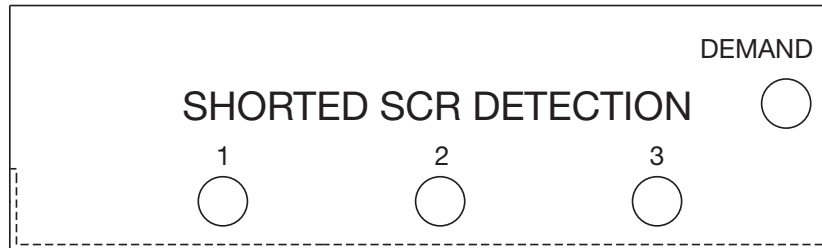

### Shorted SCR Detection (optional), cont'd.

The latching and non-latching option is jumper selectable; the jumper is located on the plug-in shorted SCR detection board. Latching and non-latching operation by the output at J1 - 5 & 6 is controlled by J3 on the shorted SCR detection board 0135-28096. When this jumper is installed, latching operation is achieved. The drawing below shows the Shorted SCR Detection board.

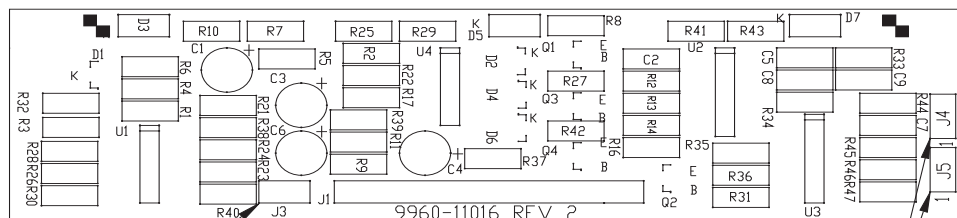

J3 JUMPERED FOR LATCHING.

FOR 1 PHASE DETECTION J4 & J5 ARE INSTALLED.  
 FOR 2 PHASE DETECTION REMOVE J4, LEAVE J5 INSTALLED.  
 FOR 3 PHASE DETECTION REMOVE J4 & J5.

UNIT SHIPPED IN NON-LATCHING MODE.

### Heat Sink Over-Temperature

An external lamp or relay may be connected to J1 - 3 & 4 (see Fig. 2 on page 15) (this must be rated for the instrument power applied to J1 - 1 & 2). This will provide an indication to the operator that the heat sink is approaching an unsafe temperature level. The unit will enter a shutdown mode if the temperature continues to rise.

**Input Terminals (MiniMax 1, 2, and 3):**

**FIG 1.**

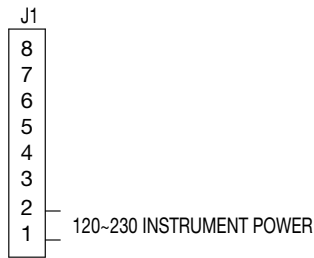

**120-230 INSTRUMENT POWER  
REQUIRED ON ALL CONFIGURATIONS**

**FIG 2.**

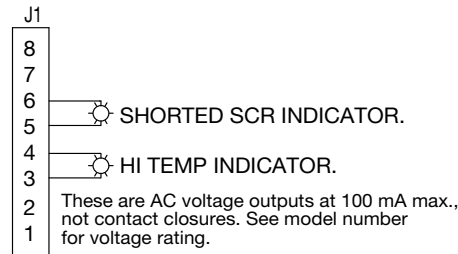

**SHORTED SCR AND  
HI TEMP INDICATORS.**

**FIG 3.**

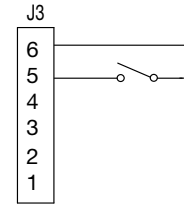

**SHORTED SCR INDICATOR RESET.**

**FIG 4.**

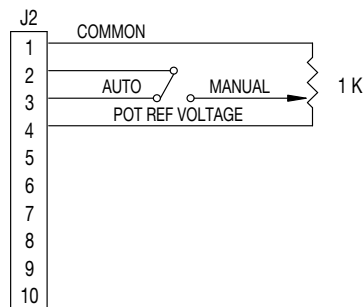

**MANUAL CONTROL INPUT SIG**

**FIG 5.**

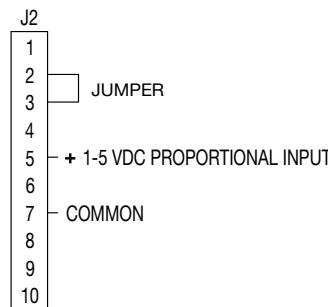

**1-5 VDC PROPORTIONAL INPUT SIG**

**FIG 6.**

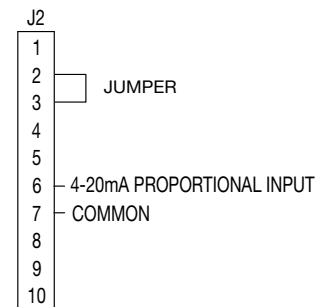

**4-20mA PROPORTIONAL INPUT SIG**

**FIG 7.**

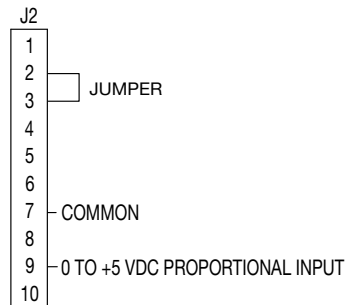

**0 TO +5 VDC PROPORTIONAL INPUT SIG**

**FIG 8.**

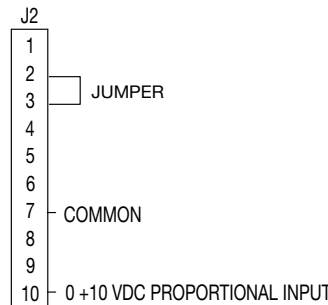

**0 +10 VDC PROPORTIONAL INPUT SIG**

**FIG 9.**

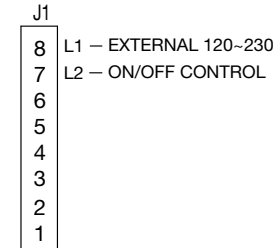

**120-240 ON/OFF CONTROL**

**FIG 10.**

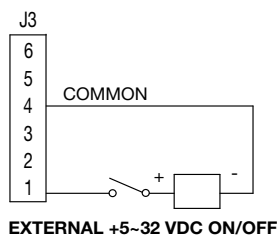

**EXTERNAL +5-32 VDC ON/OFF**

**FIG 11.**

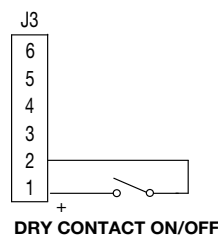

**DRY CONTACT ON/OFF**

**FIG 12.**

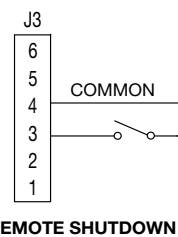

**REMOTE SHUTDOWN**



## MiniMax 1P

The Chromalox MiniMax 1P is a solid-state proportional power controller that utilizes a Phase Angle firing technique to modulate power to an inductive or resistive load. Separate adjustable Zero, Gain, Manual Bias, and Current Limit potentiometers are provided along with screw type plug-in connectors for input signals, Emergency Shutdown, and optional Remote Manual Bias with 0 - 100% dial. All units have thermostat protection with N.C. contacts.

### Start-up

The MiniMax 1P has been factory calibrated for 4 - 20 mA input. Be sure the operating voltage and signal input are correctly applied. Also, make sure the Emergency Shutdown, if used, has N.O. contacts and jumper pins 4 & 5 on the 10-pin connector if remote manual bias are not used. Please read the information on calibration at the end of this section for current limit settings for loads with extreme hot to cold ratios or those that are overrated. Other ranges may be field calibrated by use of zero and gain potentiometers.

### CAUTION

**IMPORTANT:** With the Current Limit option, the current transformer must be terminated properly to prevent it from being damaged.

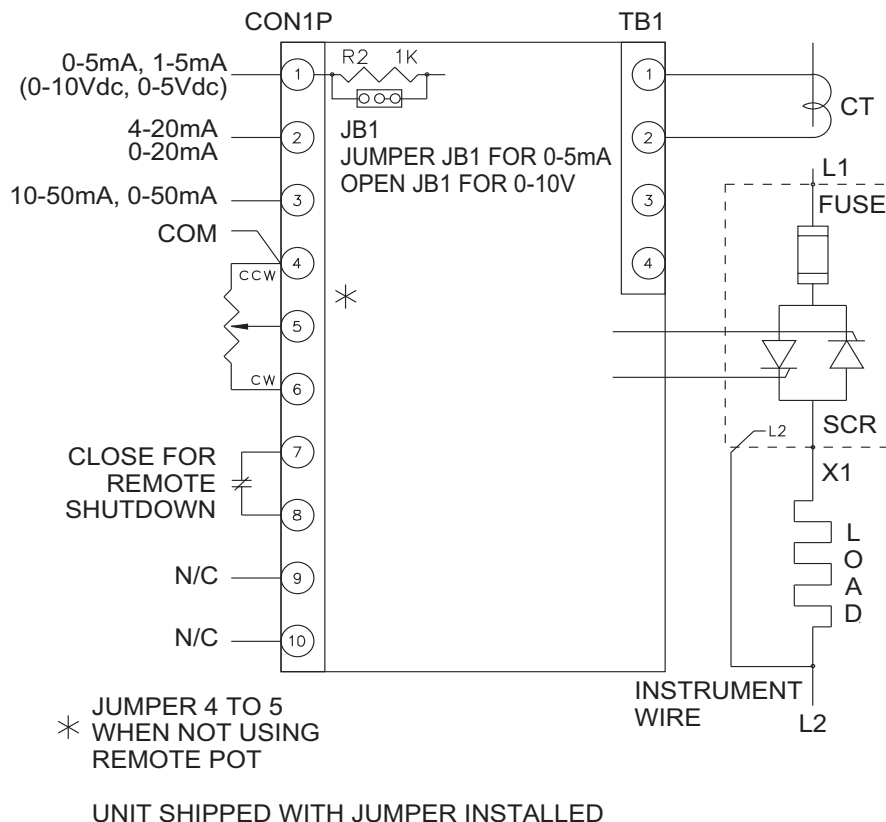

### Customer Connection

#### 4.2.5 - Calibration (MiniMax 1P):

Many high-temperature heating elements exhibit extreme hot to cold resistance ratios. Heating elements composed of Platinum, Molybdenum, Tungsten, and Tantalum, to name a few, draw excessive current on start-up. Depending on the mass of the elements, these “high starting currents” may exist for extended periods of time. Generally, once the elements have achieved their normal operating temperatures, the current drawn through the MiniMax Power Pak will fall within the rating of the unit. For these types of loads, we recommend adjusting the I LIM (Current Limit) to 50% or less. This will decrease voltage as well as current.

1. Set Current Limit (I LIM) pot to 0% for full current output (CCW).  
Current Limit is for limiting current for loads that have extreme hot to cold resistance ratios or are overrated. We recommend for these types of loads to adjust I LIM (Current Limit) to 50% or less. This will also decrease voltage as well as current. 0% Current Limit gives 100% current output (CCW). 100% Current Limit gives 10% current output (CW).
2. Set Manual (MAN) pot to zero so unit will not be biased above input (CCW).  
Manual control adjustment provides a means of setting the output level of the MiniMax Power Pak in the absence of controlling instrumentation. The manual control signal value “adds” to the controlling instrument to set minimum output. The desired output power level may be set by adjusting the manual control. This value of output will then be present even in the absence of a control signal.
3. Set Remote Manual pot to zero output so unit will not be biased above input (CCW). (Jumper pins 4 & 5 if not used.)  
Remote Manual control adjustment provides a means of setting the output level of the MiniMax Power Pak in the absence of controlling instrumentation. The Remote Manual control is also effective when a control signal is connected. The Remote Manual control signal value “adds” to the controlling instrument to set minimum output. The desired output power level may be set by adjusting the Remote Manual control. This value of output will then be present even in the absence of a control signal. Connect Remote Manual pot wire to Pin 4 (CCW), Pin 5 (W), and Pin 6 (CW) of plug-in connector.
4. Check for open contact for Emergency Shutdown.  
Emergency Shutdown inhibits all SCR trigger pulses regardless of the level of the input signal or manual potentiometer. For Emergency Shutdown, close contact Pin 7 to Pin 8 of plug-in connector. Leave contacts open for operation.
5. Check for polarity of input signal.
6. Adjust input signal to low end of scale.  
Zero Adjust control sets the power output starting point or reference. Thus, it effectively cancels positive inputs to the MiniMax Power Pak.  
EXAMPLE: 0 - 5 mA input → set to 0 mA input  
4 - 20 mA input → set to 4 mA input
7. With power off, connect line voltage and load as shown.
8. Connect meter to input and output.  
WARNING: Set meter to correct scale to read proper input or output.
9. Apply power to unit.
10. Adjust input signal to low end of scale.
11. Using the Zero pot, adjust the output voltage just to zero volts.
12. Adjust input signal to top end of scale.  
Gain Adjust Control sets the maximum power output for maximum input signal.  
EXAMPLE: 0 - 5 mA input: set to 5 mA input  
4 - 20 mA input: set to 20 mA input
13. Using the Gain pot, adjust output voltage just to maximum volts.
14. Repeat steps 11, 12, 13, and 14 until no adjustment is necessary of Zero and Gain pots for proper output voltage indication. Voltage output should increase proportionally to the signal input applied.
15. Adjust input signal to low end of scale (zero voltage output).
16. With Manual pot at zero for zero voltage output, adjust (CW) to 100% for full voltage output. Voltage output should increase proportionally. Return to CCW position and output will decrease to zero output.
17. With Remote Manual at zero for zero voltage output, adjust (CW) to 100% for full voltage output. Voltage output should increase proportionally. Return to CCW position and output will decrease to zero output.
18. With Manual pot (CW) at 100% and I LIM (Current Limit) at 0%, adjust I LIM towards 100% noting that voltage output decreases with the adjustment of the Current Limit pot. Adjust Current Limit pot for your application, if needed.
19. Turn POWER OFF and remove meters. TEST COMPLETE.

# 5 Specifications

## MiniMax 1, 2, and 3

### Control Inputs

Accepts all of the following as standards:

### On/Off Control

Signal Input  
120 thru 230 Vac  $\pm$  10%  
5-32 Vdc  
Contact Closures

### Proportional Control

Signal Input	Input Impedance
4 - 20 mA.....	250 Ohms
1 - 5 Vdc.....	10k Ohms or greater
0 - 5 Vdc.....	10k Ohms or greater
0 - 10 Vdc.....	10k Ohms or greater

Optional Remote Manual Adjust  
Auto/Manual Switch

**Instrument Power** ..... 120 or 230 Vac  
50/60 Hz

**Output Voltage** ..... 0 - 99% RMS line voltage  
( $E_o = V_{supply} - 1.5V$  SCR forward drop)

**Resolution (proportional)** Better than 0.1%

**Line Voltage** .....120 - 575 Vac, 60 Hz  
CE 400 Vac, 50 Hz

**Load Current Rating** .....30, 50, 75

**Ambient Temperature** ....0 - 50°C (32 - 122°F)

### SCR Capability

Dielectric	Withstand capability
Surge Rating	1500V RMS min. Typically fifteen (15) times nominal RMS rating for 8.3 milliseconds
Isolation	SCRs isolation 2500V Input-output isolation 1500V

**Heat Sink** .....Ground potential up to 650 Amps

**High Temperature** .....Voltage Output  
**Indicator Output** 100 mA @ Instrument Power

**Shorted SCR** .....Voltage Output  
**Indicator Output** 100 mA @ Instrument Power

## MiniMax 1P

### Control Inputs

Accepts all of the following as standards:

### Phase Angle Control

Signal Input	Input Impedance
1 - 5, 0 - 5 mA.....	1K Ohms
4 - 20, 0 - 20 mA.....	250 Ohms
10 - 50, 0 - 50 mA...	100 Ohms

Optional Remote Manual Adjust

**Fan Power** ..... 120 or 230 VAC  
50/60 Hz

**Output Voltage** ..... 0 - 99% RMS line voltage

**Resolution (proportional)** Better than 0.1%

**Line Voltage** ..... 120, 208, 240, 277, 380,  
480 and 575 Vac  
 $\pm$  10% 50/60 Hz

**Load Current Rating**... 30, 50, 75

**Ambient Temperature**.....0 - 50°C (32 - 122°F)

**SCR Capability**.....Withstand capability  
1500V RMS min.  
Typically fifteen (15) times nominal RMS rating for 8.3 milliseconds

**Surge Rating** .....Typically fifteen (15) times nominal RMS rating for 8.3 milliseconds

**Isolation**.....SCRs isolation 2500V  
Input-output isolation 1500V



**Heat Sink** .....Ground potential up to 650 Amps

**Thermostat**.....4 Amps @ 120V resistive  
2 Amps @ 240V resistive  
N.C. Contact Standard

**Current Limit** .....10 - 100% of rated output current

**Soft Start** .....25% demand per second  
typical reset speed  
8.3 milliseconds

## 6 Maintenance

	 <b>WARNING</b>
	<b>Hazardous Voltage:</b> Disconnect all power before performing any maintenance or examining the power module. Exposed terminals may carry LETHALLY HIGH VOLTAGES when power is applied.

**Connections** – Loose connections in the power wiring will generate hot spots. These will cause degradation of electronic equipment. Periodic inspections should be made to ensure that connections are secure and that there are no signs of excessive heating such as discoloration, and so on.

**Corrosion** – If the power module is installed in an environment with high humidity or dampness, electrical connections may suffer corrosion. Periodically check the power module for corrosion.

**Damage** – Periodically check for rodent damage to wiring and other components.

**Filters** – Many high-powered control enclosures rely on blowers or fans to maintain a safe operating temperature. The filters used with these devices should be changed on a periodic basis to insure adequate enclosure cooling is maintained.

**Dust** – Periodically check for dust or other particulate buildup on heatsinks and bus bars.

# 7

## Troubleshooting

The following guidelines cover most of the common problems that could occur with the MiniMax. They are not intended to be, nor can they be, absolutes to cover every possible failure.

### Problem

#### **No Power or unbalanced power to the load.**

If Demand Light is “**Off**”

1. Check incoming line power.
2. Check the instrument power.
3. Check the fuse on the main board.
4. Verify the input signal.
5. Check that remote shutdown J3 - 3 to 4 is open.
6. Check that the J2 - 2 to 3 is Jumpered.
7. Verify that heat sink is not in over temperature mode by removing temperature sensor plugs from J10, J11, and J12.

If Demand Light is “**On**”

1. Check the connections to SCR trigger board.
2. Check the power fuses (I<sup>2</sup>t).
3. Look for damage on the trigger board.

# 8 Parts and Accessories

## Instrument Power Fuse

### Chromalox Part Number

0024-01097

### Description

Littlefuse # 225 002 2 AG 2AMP

## I<sup>2</sup>T Fuses for 500 Vac Applications

0024-03015

40 Amp I<sup>2</sup>t Fuse

0024-03085

70 Amp I<sup>2</sup>t Fuse

0024-03072

100 Amp I<sup>2</sup>t Fuse

## I<sup>2</sup>T Fuses for 575 Vac Applications

0024-03033

40 Amp I<sup>2</sup>t Fuse

0024-03137

70 Amp I<sup>2</sup>t Fuse

0024-47561

100 Amp I<sup>2</sup>t Fuse

## SCR Replacement (120 - 480 Vac)

Be sure to replace thermstrate interface material and torque as follows:

<u>MFG Part #</u>	<u>SCR Part #</u>	<u>Thermstrate Part #</u>	<u>Torque inch/lb to Heat Sink</u>	<u>Torque inch/lb to Terminals</u>
SKKT42	0002 - 42508	0029 - 00700	44 inch/lb (5 Nm)	26 inch/lb (3Nm)
SKKT92	0002 - 47560	0029 - 00700	44 inch/lb (5 Nm)	26 inch/lb (3Nm)

## SCR Replacement (575 Vac)

Be sure to replace thermstrate interface material and torque as follows:

<u>MFG Part #</u>	<u>SCR Part #</u>	<u>Thermstrate Part #</u>	<u>Torque inch/lb to Heat Sink</u>	<u>Torque inch/lb to Terminals</u>
SKKT42/14E	0002 - 42519	0029 - 00700	44 inch/lb (5 Nm)	26 inch/lb (3Nm)
SKKT92/14E	0002 - 47561	0029 - 00700	44 inch/lb (5 Nm)	26 inch/lb (3Nm)

## MiniMax 1, 2, and 3

### Accessories:

<u>Part Number</u>	<u>Description</u>
0135 - 28096	Plug-In Shorted SCR Detection Board
0135 - 28095	Plug-In Proportional DOT-Fired Control Board
0135 - 28093	SCR Trigger Board
0135 - 28094	On/Off Main Firing Board
0135 - 20117	Potentiometer & Remote/Manual Switch

### For CE Application, the Following Filters are Required:

0005 - 60055	Line Filter Single Phase 230 Vac
0005 - 60057	Line Filter 120 - 230 Vac 3 Amps
0005 - 60056	Line Filter Three Phase 440 Vac

## MiniMax 1P

### Accessories:

<u>Part Number</u>	<u>Description</u>
0135 - 28002	Firing Circuit 120, 240 Vac
0135 - 28006	Firing Circuit 208, 277, 480 Vac
0135 - 28037	Firing Circuit 380 Vac

## **Warranty and Return Information**

### **Warranty Notice**

The Warranty below complies with the federal law applicable to products manufactured after December 31, 1976. This warranty gives you specific legal rights and you may also have other rights which vary from state to state.

### **Chromalox Warranty**

Chromalox Instruments and Controls are warranted against defects in workmanship and materials. No other express warranty, written or oral, applies with the exception of a written statement from an officer of Chromalox®, Inc.

### **Warranty Period**

This warranty extends for three years from date of shipment from the factory or authorized distributor.

### **Limitations**

Products must be installed and maintained in accordance with Chromalox instructions. Users are responsible for the suitability of the products to their application. There is no warranty against damage resulting from corrosion, misapplication, improper specification or other operating conditions beyond our control. Claims against the carrier company for damage in transit must be filed by the buyer.

### **Returns**

Items returned to Chromalox Instruments and Controls must be accompanied by a Return Authorization Number. This number may be obtained from Chromalox Instruments and Controls' Customer Service Department at the phone number listed below.

The Return Authorization Number must appear on the exterior of the shipping carton and on the shipping documents.

Defective items will be repaired or replaced at our option and at no charge.

Return the defective part or product, freight prepaid, to the following address:

Chromalox Instruments and Controls  
1347 Heil Quaker Blvd.  
LaVergne, TN 37086-3536

Phone: (615) 793-3900

Fax: (615) 793-3563

## MiniMax 1 Ordering Information

Model SCR Power Pack

### Mmax 1 Single Phase SCR Power Controller Complete with Lugs and I<sup>2</sup>T Fusing<sup>1,2</sup>

#### Code Control Configuration

1	On/Off Standard (Accepts: 120Vac, 240Vac, 5-32Vdc, Dry Contact Closure)
2	On/Off Standard with Shorted SCR Detection
3	Proportional Control, DOT Firing (Accepts: 4-20mA, 1-5Vdc, 0-5Vdc, 0-10Vdc)
4	Proportional Control, DOT Firing with Shorted SCR Detection

#### Code Current at 50°C (104°F) Ambient

01	30 Amp
02	50 Amp
03	75 Amp

#### Code Line Voltage

1	120 - 480Vac
2	575Vac

#### Code Instrument Power

1	120 to 240Vac 50/60Hz
---	-----------------------

#### Code Remote Manual Adjust/Auto Manual Switch<sup>3</sup>

0	None
1	Pot with 0 - 100% dial and local/Remote Switch, Single Turn 1K ohm Potentiometer (Requires Proportional Board)

Mmax I - 3 01 1 1 0 Typical Model Number

- 1) SCR Fusing is for semiconductor protection only, not wire protection.
- 2) Supplied loose for customer mounting. 575V Fusing only
- 3) Supplied loose for customer mounting

**Note:**

Storage Temperature 14°F to 158°F (-10°C to 70°C).  
CE application requires filters.

**Chromalox Part Numbers**

0005-60055 — Line filter, single phase, 230VAC  
0005-60057 — Line filter, 120-230VAC

**CE application requires filter.**



## MiniMax 1P Ordering Information

**Model 1P Power Pack**

**Mmax 1P Single Phase SCR Power Controller Complete with Lugs and I<sup>2</sup>T Fusing<sup>1,2</sup>**

**Code Control Configuration**

- 1** Phase Angle Control (Accepts: 1 - 5/0 - 5mA, 4 - 20/0 - 20mA, 10 - 50/0 - 50mA)
- 2** Phase Angle Control with Current Limit

**Code Current at 50°C (104°F) Ambient**

- 01** 30 Amp
- 02** 50 Amp
- 03** 75 Amp

**Code Voltage**

- 1** 120 Vac
- 2** 208 Vac
- 3** 240 Vac
- 4** 277 Vac
- 5** 480 Vac
- 6** 575 Vac

**Code Remote Manual Adjust/Auto Manual Switch<sup>3</sup>**

- 0** None
- 1** Pot with 0-100% dial and local/Remote Switch, Single Turn 1K ohm Potentiometer (Requires Proportional Board)

**Mmax 1P - 2 01 1 1 Typical Model Number**

- 1) SCR fusing is for semiconductor protection only, not wire protection.
- 2) Supplied loose for customer mounting. 575V fusing only
- 3) Supplied loose for customer mounting.

**Note:**

Storage temperature 14°F to 158°F (-10°C to 70°C).  
SCR units calibrated for 4-20mA input.

## MiniMax 2 Ordering Information

Model	SCR Power Pack										
<b>Mmax2</b>	<b>3 Phase SCR Power Controller complete with Lugs and I2T Fusing<sup>1,2</sup></b>										
	<table border="1"> <thead> <tr> <th>Code</th> <th>Control Configuration</th> </tr> </thead> <tbody> <tr> <td>1</td> <td>On/Off Standard (Accepts: 120 Vac, 240 Vac, 5-32 Vac, Dry Contact Closure)</td> </tr> <tr> <td>2</td> <td>On/Off Standard with Shorted SCR Detection</td> </tr> <tr> <td>3</td> <td>Proportional Control, DOT Firing (Accepts: 4-20mA, 1-5Vdc, 0-5Vdc, 0-10Vdc)</td> </tr> <tr> <td>4</td> <td>Proportional Control DOT with Shorted SCR Detection</td> </tr> </tbody> </table>	Code	Control Configuration	1	On/Off Standard (Accepts: 120 Vac, 240 Vac, 5-32 Vac, Dry Contact Closure)	2	On/Off Standard with Shorted SCR Detection	3	Proportional Control, DOT Firing (Accepts: 4-20mA, 1-5Vdc, 0-5Vdc, 0-10Vdc)	4	Proportional Control DOT with Shorted SCR Detection
Code	Control Configuration										
1	On/Off Standard (Accepts: 120 Vac, 240 Vac, 5-32 Vac, Dry Contact Closure)										
2	On/Off Standard with Shorted SCR Detection										
3	Proportional Control, DOT Firing (Accepts: 4-20mA, 1-5Vdc, 0-5Vdc, 0-10Vdc)										
4	Proportional Control DOT with Shorted SCR Detection										
	<table border="1"> <thead> <tr> <th>Code</th> <th>Current at 50°C (104°F) Ambient</th> </tr> </thead> <tbody> <tr> <td>01</td> <td>30 Amp</td> </tr> <tr> <td>02</td> <td>50 Amp</td> </tr> <tr> <td>03</td> <td>75 Amp</td> </tr> </tbody> </table>	Code	Current at 50°C (104°F) Ambient	01	30 Amp	02	50 Amp	03	75 Amp		
Code	Current at 50°C (104°F) Ambient										
01	30 Amp										
02	50 Amp										
03	75 Amp										
	<table border="1"> <thead> <tr> <th>Code</th> <th>Line Voltage</th> </tr> </thead> <tbody> <tr> <td>1</td> <td>120 - 480 Vac</td> </tr> <tr> <td>2</td> <td>575 Vac</td> </tr> </tbody> </table>	Code	Line Voltage	1	120 - 480 Vac	2	575 Vac				
Code	Line Voltage										
1	120 - 480 Vac										
2	575 Vac										
	<table border="1"> <thead> <tr> <th>Code</th> <th>Instrument Power</th> </tr> </thead> <tbody> <tr> <td>1</td> <td>120 to 240Vac 50/60Hz</td> </tr> </tbody> </table>	Code	Instrument Power	1	120 to 240Vac 50/60Hz						
Code	Instrument Power										
1	120 to 240Vac 50/60Hz										
	<table border="1"> <thead> <tr> <th>Code</th> <th>Remote Manual Adjust/Auto Manual Switch<sup>3</sup></th> </tr> </thead> <tbody> <tr> <td>0</td> <td>None</td> </tr> <tr> <td>1</td> <td>Pot with 0-100% dial and local/Remote Switch, Single Turn 1K ohm Potentiometer (Requires Proportional Board)</td> </tr> </tbody> </table>	Code	Remote Manual Adjust/Auto Manual Switch <sup>3</sup>	0	None	1	Pot with 0-100% dial and local/Remote Switch, Single Turn 1K ohm Potentiometer (Requires Proportional Board)				
Code	Remote Manual Adjust/Auto Manual Switch <sup>3</sup>										
0	None										
1	Pot with 0-100% dial and local/Remote Switch, Single Turn 1K ohm Potentiometer (Requires Proportional Board)										
<b>Mmax2 -</b>	<b>3 01 1 1 0 Typical Model Number</b>										

- 1) SCR fusing is for semiconductor protection only, not wire protection.
- 2) Supplied loose for customer mounting. 575V fusing only
- 3) Supplied loose for customer mounting.

**Note:**

Storage Temperature 14°F to 158°F (-10°C to 70°C).  
 CE Application requires filters.

**Chromalox Part Numbers**

0005-60056 — Line filter, three phase, 440VAC  
 0005-60057 — Line filter, 120-230VAC

**CE application requires filter.**

## MiniMax 3 Ordering Information

Model	SCR Power Pack					
Mmax3	3 Phase Six SCR Power Controller Complete with Lugs and I <sup>2</sup> T Fusing					
	<b>Code</b>	<b>Control Configuration</b>				
	1	On/Off Standard (Accepts: 120 Vac, 240 Vac, 5-32Vdc, Dry Contact Closure)				
	2	On/Off Standard with Shorted SCR Detection				
	3	Proportional Control, DOT Firing (Accepts: 4-20mA, 1-5Vdc, 0-5-Vdc, 0-10Vdc)				
	4	Proportional Control, DOT Firing with Shorted SCR Detection				
		<b>Code</b>	<b>Current at 50°C (104°F) Ambient</b>			
		01	30 Amp			
		02	50 Amp			
		03	75 Amp			
			<b>Code</b>	<b>Line Voltage</b>		
			1	120 - 480 Vac		
			2	575 Vac		
				<b>Code</b>	<b>Instrument Power</b>	
				1	120 to 240 Vac 50/60Hz	
					<b>Code Remote Manual Adjust/Auto Manual Switch</b>	
				0	None	
				1	Pot with 0-100% dial and local/Remote Switch, Single Turn 1K ohm Potentiometer s(Requires Proportional Board)	
<b>Mmax3-</b>	<b>3</b>	<b>01</b>	<b>1</b>	<b>1</b>	<b>0</b>	<b>Typical Model Number</b>

- 1) SCR fusing is for semiconductor protection only, not wire protection.
- 2) Supplied loose for customer mounting. 575V fusing only
- 3) Supplied loose for customer mounting.

**Chromalox Part Numbers**

0005-60056 — Line filter, three phase, 440VAC  
 0005-60057 — Line filter, 120-230VAC

**CE application requires filter.**

**Note:**

Storage Temperature 14°F to 158°F (-10°C to 70°C).  
 CE Application requires filters.

## EC Declaration of Conformity

We, Chromalox Precision Heat and Control  
1347 Heil Quaker Boulevard  
LaVergne, Tennessee 37086-3536

Phone: +1 (615) 793-7561  
Fax: +1 (615) 213-8091

declare under sole responsibility that the following described product in our delivered version complies with the appropriate basic safety and health requirements of the EC Low Voltage Directive (2006/95/EC) and EC Electromagnetic Compatibility Directive (2004/108/EC) based on its design and type, as brought into circulation by us. In case of alteration of the machine, not agreed upon by us, this declaration will lose its validity.

Description of the Electrical Equipment: MiniMax SCR controllers

Model Number: MiniMax Series; MiniMax 1, 2, 3

### Applicable Harmonized Standards:

	<b>Low Voltage Directive</b>	<b>EMC Directive</b>
Specification:	EN60947-4-3:2000 Low-voltage switch gear and control gear	1. Radiated Disturbance Emissions – 30 to 1000 MHz Electric Field EN 61000-6-4:2001 / EN 55011:2007
	Part 4-3: Contactors and motor-starters AC semiconductor controllers and contactors for non-motor loads	2. Conducted Disturbance Emissions – Voltage EN 61000-6-4:2001 / EN 55011:2007
Utilization Category:	AC-51 Non-inductive or slightly inductive loads, resistive furnaces	3. Conducted Disturbance Immunity EN 61000-6-2:2005 / EN 61000-4-6:1996
Pollution Degree 2	Normally only non-conductive pollution occurs. Occasionally, a temporary conductivity caused by condensation may be expected.	4. Radiated Disturbance Immunity EN 61000-6-2:2005 / EN 61000-4-3:1995
Voltage Rating:	400 Vac 50 Hz Line 230 Vac 50 Hz Instrument max 75 watts	5. Electrical Fast Transients/Bursts Immunity EN 61000-6-2:2005 / EN 61000-4-2:1995
Impulse Rating:	2.5 KV for 5 seconds	6. Voltage Dips and Interrupts Immunity EN 61000-6-2:2005 / EN 61000-4-11:1994
Overload Current Profile:	140% for 1 second	7. Electrostatic Discharge Immunity EN 61000-6-2:2005 / EN 61000-4-2:1995
Fuses:	500 Volt, 200KA RMS symmetrical interrupting rating, I <sub>t</sub> fusing provided with all CE units.	8. Voltage Fluctuations/Flicker EN 61000-3-3 / A2:2005
		9. Harmonic Current Emissions EN 61000-3-2:2006

Filters Required: Instrument power filter: 10. Surge Immunity  
Chromalox P/N 0005-60057 EN 61000-6-2:2005 / EN 61000-4-5:1995  
Line Filter, single phase:  
Chromalox P/N 0005-60055  
Line Filter, three phase:  
Chromalox P/N 0005-60056

The Technical documentation required by Annex IV (3) of the Low Voltage Directive is maintained by (Name) of (company and location in the European Union)

Year in which CE Marking was affixed: 2002

Authorized Signature/Date:   
Jim Birnie

November 18, 2008  
Date

Title of Signatory: Engineering Manager

Chromalox, International  
Unit 1.22, Lombard House  
2 Purley Way  
Croydon CRO 3JP  
Surrey  
U.K.