

## Cast-In Heaters



Liquid-Cooled

### Reasons Why OEMs

### Specify Tempco's Quality

### Liquid-Cool Cast-In Aluminum Heaters

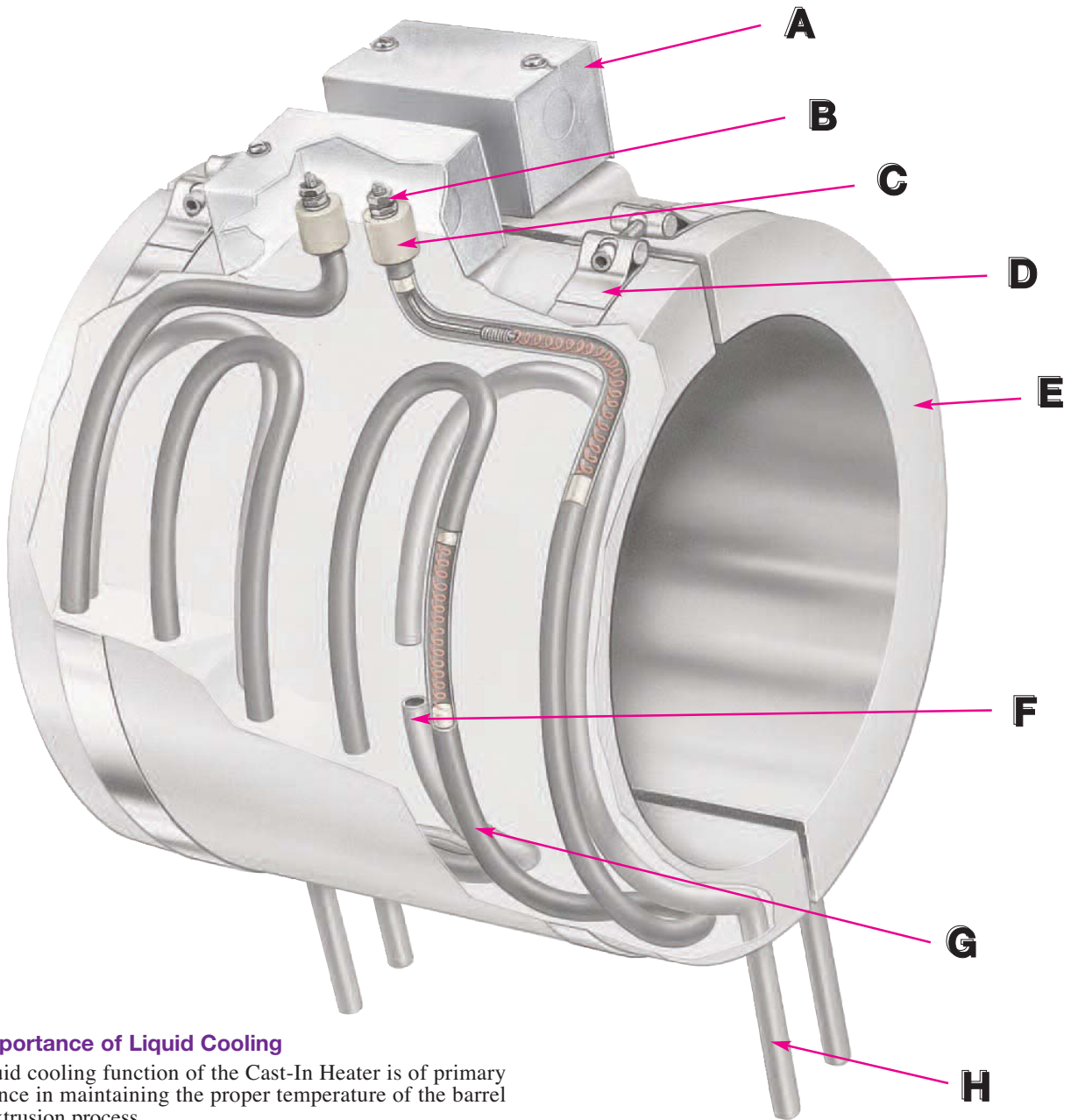

#### The Importance of Liquid Cooling

The liquid cooling function of the Cast-In Heater is of primary importance in maintaining the proper temperature of the barrel in the extrusion process.

Tempco offers many different liquid cooling variations, styles and terminations. The following pages will assist you in selecting the liquid cooling system best suited to your application. See page 3-63 for complete details on how to order.



***THE PERFORMANCE FACTS***

**A** General purpose stainless steel terminal boxes provide a simple and economical way to eliminate exposure to live electrical terminals. To simplify electrical wiring, the box has two knockouts for standard 1/2" BX cable connectors. Boxes can be supplied factory prewired with high temperature lead wire protected with armor cable or wire braid. Other boxes are available to accommodate your requirements. See pages 3-56 and 3-57.

**B** Threaded post terminals with 10-32 threads are securely fastened to the tubular heating element cold pin, assuring positive electrical contact for maximum amperage carrying capacity. Other terminations are available to accommodate your requirements. See pages 3-54 and 3-55.

**C** The standard Type "S" terminal has specially designed ceramic insulators that provide support to the screw terminals. The tubular heater is recessed into the insulator to help prevent the screw terminals from bending or breaking from mechanical abuse. Other specially designed ceramic insulators are available for the screw terminals and the connecting wire. See page 3-54.

**D** Specially designed, low expansion 430 stainless steel clamping straps with 1/4"-20 socket head cap screws and barrel nuts, in either 3/4" or 1-1/4" widths, are supplied as our standard method for securing the casting to the barrel. The number and width of the straps is determined by the length and weight of the heater. For optional bolt and nut clamping design see page 3-50.

**E** Having an in-house foundry gives us the flexibility to apply sound foundry techniques to control the quality of each casting. Specially designed steel and cast iron molds are used in our Permanent Mold Casting Process, producing a dense casting, free of internal voids with smoother as-cast surfaces. When casting small quantities, the No-Bake Sand Mold process is used. This process produces a better quality casting than other sand processes. The inside diameter of all Cast-In Band Heaters is machine finished to customer specifications.



Processing aluminum castings using a Permanent Mold.

**F** A critical consideration in the design of a heat and liquid cooled Cast-In Heater is the cooling tube itself, since cooling tube failures usually occur before heating element failures. Tempco has devoted many years of research and testing to select alloy tubes that are resistant to corrosion, and that will also withstand the continuous stress that is placed on the cooling tube. Our testing also included developing the proper tube forming techniques to limit the effects of thermal shock from repetitive heat/cool cycling that can produce stress cracking, especially at the point the cooling tube exits the casting.



Processing aluminum castings using a Sand Mold.

**G** To maintain lower watt densities important for good heater life, the largest possible diameter steel sheath tubular heater is used. Tempco most commonly uses a .430 diameter element with 1/8" diameter cold pins. This pin size allows installation of larger and stronger screw terminal connections, providing additional strength to prevent broken terminals due to mechanical abuse.

**H** Cooling tube extensions can be cut to your specified length, with various types of tube fittings factory installed. The casting can also be supplied with non-exposed cooling tube fittings, which reduce cooling tube failure due to stress corrosion cracking. For a complete selection of cooling tube terminations see page 3-52.

## Cast-In Heaters



### Liquid-Cooled Clamping Methods

#### Liquid-Cooled Cast-In Band Heaters for Extrusion Processing

##### Single Set of Cooling Tubes—The Industry Standard

The single set cooling tube design features 1/4", 3/8" or 1/2" diameter tubing precisely formed into a serpentine or any other suitable shape and cast into the body of the Cast-In Heater. This is the most widely used method for providing a means of cooling in liquid-cooled Cast-In Heaters.

From this basic design, the user can choose to factory equip the cooling tubes with any of the cooling tube termination options shown on page 3-52. Electrical termination options are shown on pages 3-54 and 3-55. The two most common clamping variations are shown below.



##### Type CW—Single Cooling Tube with Strap Clamping

Type CW Cast-In Band Heaters consist of liquid cooled and/or heating functions, and are secured to the extruder barrel with 3/4" or 1-1/4" wide low expansion stainless steel clamping straps with 1/4"-20 socket head cap screws and barrel nuts.

If not otherwise specified, supplied with Type S electrical screw termination, 3" long cooling tube extensions and straps for clamping. For a wide selection of electrical and cooling tube termination options, see pages 3-52 through 3-55. See page 3-63 for complete details on how to order.

##### Type CWB—Single Cooling Tube with Bolt Clamping

Type CWB Cast-In Band Heaters consist of liquid cooled and/or heating functions, and are secured to the barrel by bolts clamping the two halves together around the barrel. A variety of bolt clamping designs and hardware is available. Consult Tempco with your specific requirements.

If not otherwise specified, cast-in band heaters are supplied with Type S electrical screw termination and 3" long cooling tube extensions. For a wide selection of electrical and cooling tube termination options, see pages 3-52 through 3-55. See page 3-63 for complete details on how to order.

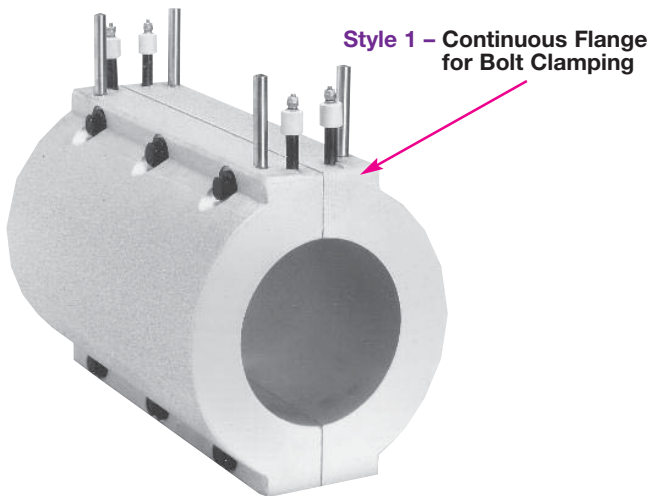

Style 1 – Continuous Flange for Bolt Clamping

Style 2 – Segmented Pads for Bolt Clamping

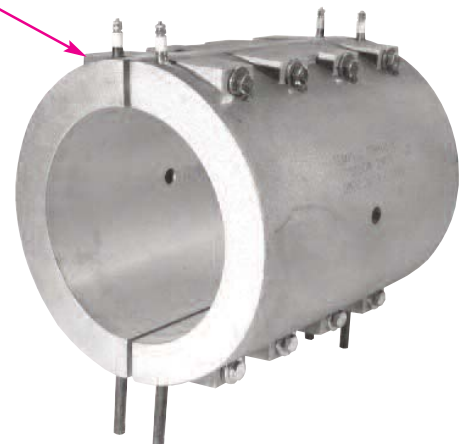



### Liquid-Cooled Cast-In Band Heaters for Extrusion Processing

#### Type CWW — Dual Set of Cooling Tubes within the Same Cast-In Heater

The Dual cooling tube design incorporates two sets of 3/8" or 1/2" diameter tubing formed into a serpentine or any other suitable shape within the same Cast-In Heater. Dual cooling tubes will actually double the operating life of a Cast-In Heater with liquid-cool function, since cooling tube failures usually occur before heating element failures.

There are two main causes for failure on liquid-cooled Cast-In Heaters: Stress corrosion cracking at the exiting point of the tube extensions and clogged lines due to scale build-up that reduces flow, decreasing cooling capacity and finally completely blocking the tube. Once the first set of cooling tubes has failed, reconnect to the spare set and you are back in operation, thus eliminating costly downtime and additional labor for heater replacement. Dual cooling tubes are also used when additional cooling capacity is required.

Cooling tube extensions can be factory equipped with your choice of fittings. Clamping styles are low thermal expansion alloy straps or bolt clamping. If not otherwise specified, supplied with Type S electrical screw termination, 3" long cooling tube extensions and straps for clamping. For a wide selection of electrical and cooling tube termination options, see pages 3-52 through 3-55. See page 3-63 for complete details on how to order.

#### Design Features

- \* *Double operating life*
- \* *Greater reliability*
- \* *Reduces costly downtime*
- \* *Better cooling capacity*
- \* *Reduces heater replacement inventory*
- \* *Various heater terminations*
- \* *Available in Bolt Clamping and Strap Clamping*
- \* *Made to customer specifications*

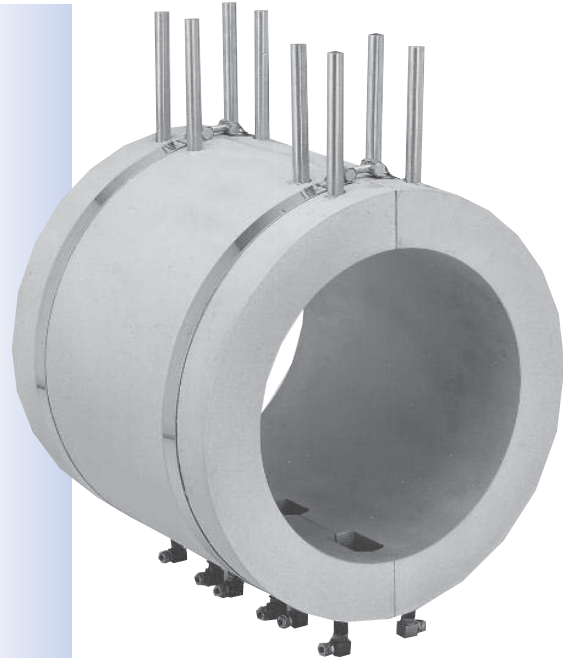

#### Type RC — Non-Exposed Cooling Tubes Recessed NPT Fittings

The recessed cooling tube design incorporates 3/8" or 1/2" diameter tubing formed into a serpentine or any other suitable shape with specially designed stainless steel NPT fittings that are welded to the tube ends and cast below the surface of the Cast-In Heater, thus eliminating the troublesome, commonly used tube extensions as they exit the casting for connection to the coolant lines.

Non-exposed fittings will drastically increase the operating life of a Cast-In Heater with liquid cool function, as this feature eliminates broken and/or damaged cooling tube extensions which are a major factor in premature heater failure. Type RC fittings are available in two female NPT thread sizes, 3/8"-18 and 1/2"-14. Standard clamping styles for Cast-In Band Heater sets are low thermal expansion alloy straps or bolt clamping. Specify fitting thread size and clamping style when ordering. If not otherwise specified, supplied with Type S electrical screw termination and straps for clamping. For fittings with special thread size, consult Tempco with your requirements. See page 3-63 for complete details on how to order.

#### Design Features

- \* *Quick and easy installation*
- \* *Exceptionally longer Cast-In Heater life*
- \* *Reduces costly downtime*
- \* *Greater reliability*
- \* *Rugged, durable construction*
- \* *Available on all cooling tube sizes*
- \* *Available in Bolt Clamping and Strap Clamping*
- \* *Made to customer specifications*

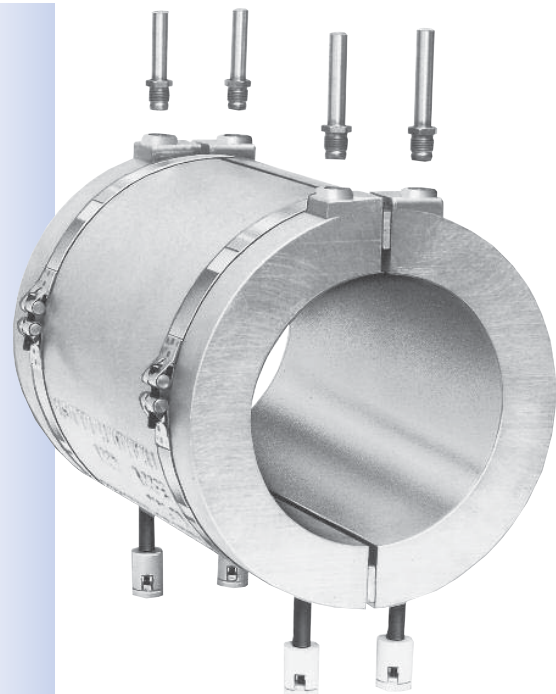

## Cast-In Heaters



### Cooling Tube Options

#### Cooling Tube Termination Options for Liquid-Cooled Cast-In Band Heaters

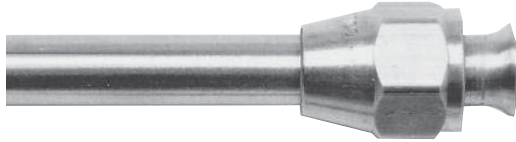

##### Type FF Flared Seal Fittings

Brass flared seal fittings are well adapted for low to medium pressure and resistant to mechanical pullout. Available for 3/8" and 1/2" diameter tubing with SAE 45° flare.

Diameter Tubing	Thread	Part Number
3/8"	5/8"-18	FTG-124-101
1/2"	3/4"-16	FTG-124-104

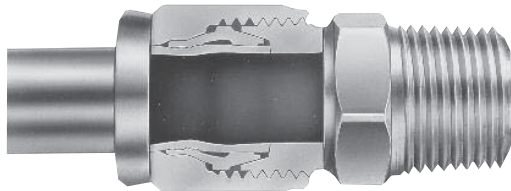

##### Type HS Hi-Seal Fittings

Hi-seal brass fittings are highly dependable under the most adverse conditions. For reliable and trouble-free service with ease of installation, we strongly recommend hi-seal fittings. Available for 3/8" and 1/2" diameter tubing. Male thread is 1/2" NPT for 1/2" tube and 3/8" tube.

Diameter Tubing	Part Number
3/8"	FTG-118-124
1/2"	FTG-118-116



##### Type RA 90° Copper Elbow

90° copper elbow is brazed to the Cast-In Heater cooling tube extension with additional tube extension for connecting cooling lines with compression and/or flared fittings. Available for 3/8" and 1/2" diameter tubing. If required, specify.

Diameter Tubing	Part Number
3/8"	FTG-127-102
1/2"	FTG-127-103

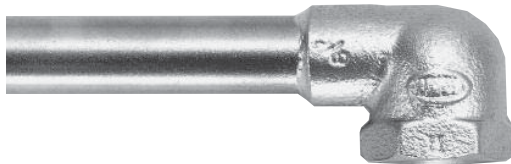

##### Type RT Cast Brass 90° Threaded Elbow

90° threaded elbow is brazed to the cooling tube extension, providing an easy and quick method for connecting cooling lines. Recommended to be factory installed to assure good braze seals. Available for 3/8" and 1/2" NPT internal threads. If required, specify.

Diameter Tubing	NPT	Part Number
1/2"	3/8"	FTG-125-101
1/2"	1/2"	FTG-125-102



##### Type R3 Straight Threaded Copper Fitting

Straight threaded fitting is brazed to the cooling tube extensions, providing an easy and quick method for connecting cooling lines. Recommended to be factory installed to assure good braze seals. Available for 3/8" and 1/2" diameter tubing with internal threads. If required, specify.

Diameter Tubing	NPT	Part Number
3/8"	3/8"	FTG-131-103
1/2"	3/8"	FTG-131-102
1/2"	1/2"	FTG-131-101



## Cast-In Heaters

### Cooling Tube Accessories

#### Installation Accessories for Liquid-Cooled Cast-In Band Heaters

##### Stock Tubing for Cooling Lines

Cooling Line Tubing can be used to connect the Tempco Cast-In heat/cool bands to the plumbing system of your extruder. Tubing is available in 6'8" lengths for U.P.S. shipments and up to 20' lengths for truck shipments. Barlow's formula below was used to calculate Working Pressure in the table.

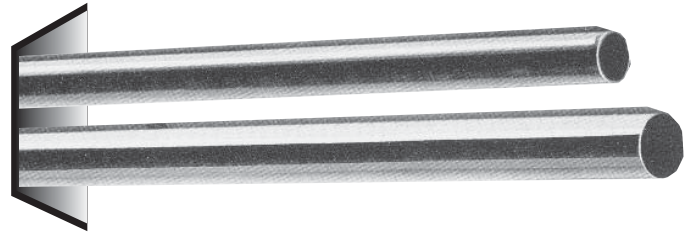

$$\text{Maximum Working Pressure (PSIG)} = \frac{2 \times \text{Material Strength (PSI at Room Temperature)} \times \text{Wall Thickness of Tube (in)}}{\text{OD of Tube (in)} \times \text{SF (Safety Factor of 1.5 to 10 depending on application)}}$$

Tubing Diameter (in)	Material	Wall Thickness (in)	Burst Pressure (PSI)	Working Pressure (Safety Factor 4) (PSI)	Material Strength (PSI)	Volume (in <sup>3</sup> /ft)	Part Number
1/4	304 SS	0.028	11200	2800	75000	0.3547	TUB-101-130
3/8	304 SS	0.035	14000	3500	75000	0.8767	TUB-101-108
1/2	304 SS	0.049	14700	3675	75000	1.5231	TUB-101-110
1/2	304 SS	0.065	19500	4875	75000	1.2903	TUB-101-122
1/2	Incoloy	0.049	17052	4263	87000	1.5231	TUB-111-108

##### Flexible Teflon® Wire Braided Hose

Flexible Teflon® Wire Braided Hose provides an excellent means of connecting Cast-In Heaters to the extruder plumbing system. This style of hose meets the demands of medium to tight bending radius requirements. The stainless steel braid protects the Teflon® hose from any harsh mechanical conditions that may be present.



A variety of brass male and female threaded fittings can be incorporated onto the hose, making it a practical choice for use in conjunction with Tempco's Style RC Non-Exposed Fittings and other available fittings.

Rigid brass adapter fittings as listed below are used to mate the base hose assembly to your existing installation. This allows for the installation of the rigid NPT coupling into the plumbing system and then attaching the swivel fitting on the hose, making assembly relatively easy. Remember to use Teflon® tape or equivalent.

**Standard Hose:** Size 8 (1/2") .405" I.D., .549" O.D.

**Operating Pressure:** 2000 PSI

**Burst Pressure:** 8000 PSI

##### Adapter Fittings for Flexible Teflon® Wire Braid Hose

Rigid brass adapter fittings are used to mate the base hose assembly to your existing installation.

T1	T2	Part Number
1/2" male 37° SAE flare	1/2"-14 NPT male	FTG-161-103
1/2" male 37° SAE flare	1/2"-14 NPT female	FTG-161-102
1/2" male 37° SAE flare	3/8"-18 NPT male	FTG-161-104
1/2" male 37° SAE flare	3/8"-18 NPT female	FTG-161-105



# Cast-In Heaters



## Electrical Termination Options

### Standard Tubular Heater Terminations for Cast-In Heaters

Select the termination style that meets your requirements for space, accessibility and reliability.

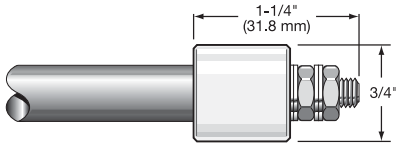

#### Type S Standard Unless Otherwise Specified

Heavy Duty Ceramic Insulators.  
 .315" diameter heater has 8-32 screw terminals.  
 .430" diameter heater has 10-32 screw terminals.

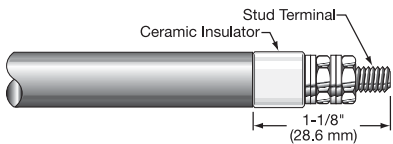

#### Type T7

Ceramic insulator is the same diameter as the heating element.  
 .260" diameter heater has 6-32 screw terminals.  
 .315" diameter heater has 8-32 screw terminals.  
 .430" diameter heater has 10-32 screw terminals.

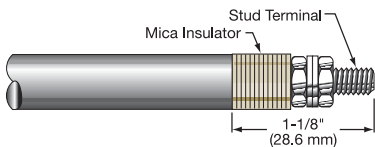

#### Type T

Mica insulator is the same diameter as the heating element.  
 .260" diameter heater has 6-32 screw terminals.  
 .315" diameter heater has 8-32 screw terminals.  
 .430" diameter heater has 10-32 screw terminals.

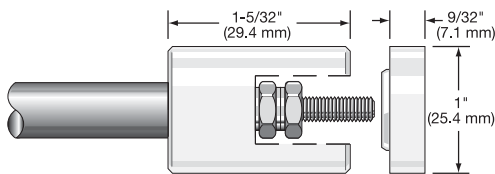

#### Type C4

Heavy duty ceramic insulator with terminal cover.  
 .315" diameter heater has 10-32 screw terminals.  
 .430" diameter heater has 10-32 screw terminals.



#### TYPE P—Plain Pin

Plain terminal pin. Specify Length "L." Standard 1/2" (12.7 mm) pin length.

Element Diameter		Nominal Pin Diameter	
in	mm	in	mm
.260	6.6	.091	2.3
.315	8.0	.100	2.5
.430	10.9	.120	3.0

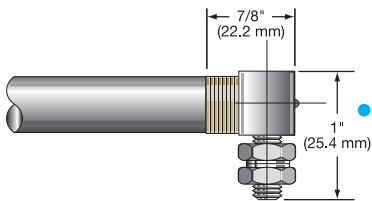

#### Type R

Mica washers with 90° blockhead screw terminal with 10-32 screw threads. Available for .315" and .430" diameter heaters.

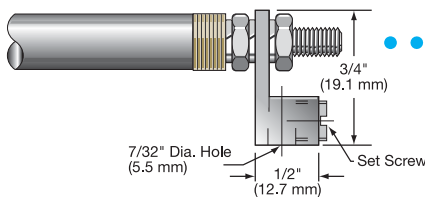

#### Type R2

Mica washers with blockhead and through hole for lead wire connection. Eliminates the use of ring terminals. Available for .315" and .430" diameter heaters. Accepts 6-14 gauge wire.

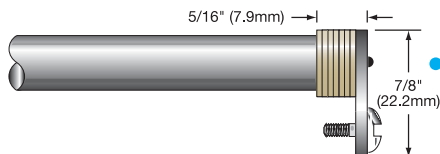

#### Type E

Right-angle lug welded to pin with mica washer insulators and 10-32 binding head screw. Available for .260", .315" and .430" diameter heaters.



### Standard Tubular Heater Terminations for Cast-In Heaters

Select the termination style that meets your requirements for space, accessibility and reliability.

#### Type L & L9

Terminal lug spot welded to pin with 10-32 binding head screw. Available for .260", .315" and .430" diameter heaters. Type L represents straight; Type L9 represents 90° to pin. Specify lug orientation.

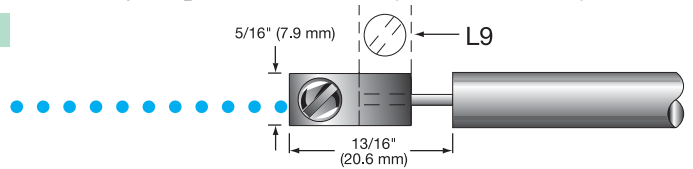

#### Type SF & SF9

Quick-disconnect spade tabs spot welded to pin. Available for .260", .315" and .430" diameter heaters. Type SF represents straight. Type SF9 represents 90° to pin. Specify tab orientation.

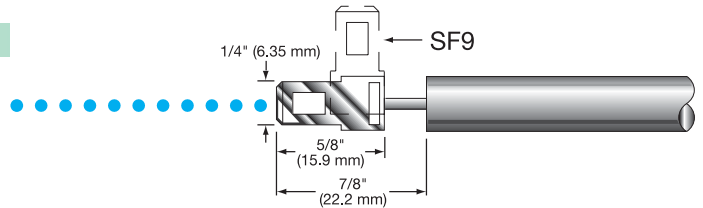

#### Type F

Flexible lead: insulated stranded wire crimped to cold pin. Crimp connection is insulated with fiberglass sleeving. Available for .260", .315" and .430" diameter heaters. Wire insulation rated to 250°C, 450°C optional. Specify lead length.



#### Type R1

Flexible Armor Cable provides excellent protection to lead wires against abrasion and contaminants. Available for .260", .315" and .430" diameter heaters. Specify cable length and lead length. Style may vary from depiction depending on heater diameter and cable diameter used.



#### Type R1A

Stainless Steel Wire Overbraid provides flexibility and excellent protection to lead wires against abrasion. Available for .260", .315" and .430" diameter heaters. Specify stainless steel wire overbraid length and lead length. Style may vary from depiction depending on heater diameter and braid diameter used.



#### Type MR

Moisture resistant shrink strain relief and lead wire with or without stainless steel overbraid. Available for .260", .315" and .430" diameter heaters. Specify lead wire and overbraid length. Maximum operating temperature is 350°F (177°C).

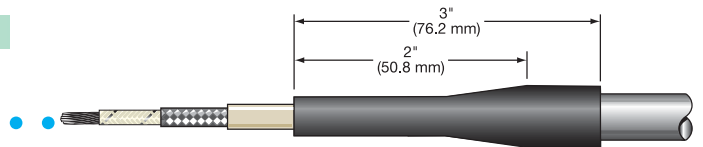

#### Type TS

Contamination seal shrink-down Teflon® sleeving over the heater and lead wire splice. Provides a good moisture resistant seal. Maximum operating temperature 500°F (260°C). Available for .260", .315" and .430" and diameter heaters. Specify lead length.

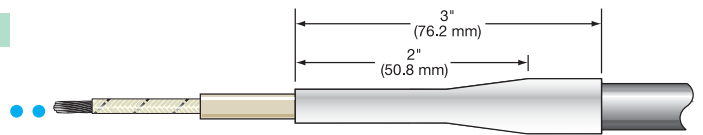

#### Type H

Ceramic to metal hermetic seal screw terminal. Maximum operating temperature is 1000°F (538°C).

	.260"	.315"	.430"
Diameter	.260"	.315"	.430"
"A" Dim.	1-11/16"	1-11/16"	2-1/8"
Thread	8-32	10-32	1/4-28

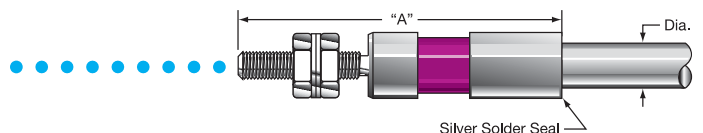



## Cast-In Heaters

### Electrical Termination Housings



### General Purpose Terminal Protection Boxes For Cast-In Heaters

#### Standard Box Type C2

Terminal Boxes provide a simple and economical means to eliminate exposed heater terminals and live electrical wiring, protecting employees from potential electrical shock. They also eliminate electrical shorts that can result from exposed wiring on Cast-In Heater installations.

Type C2 is an individual terminal box for protecting the terminals on each Cast-In Band Heater half. It is also used on many other Cast-In Heater designs with one set of heater terminals. The C2 box design requires a flat pad on half-round castings or a flat surface on other casting designs for mounting. It is made from heavy gauge, rust-resistant sheet metal. The cover is removable for easy access to terminals. The box has two 7/8" diameter knockouts opposite each other for standard 1/2" BX connectors.

To simplify installation, Cast-In Heaters fitted with boxes can be factory pre-wired with high temperature lead wire that can be protected with armor cable. If one of these options is required, **specify terminal box type, lead wire and cable length**. Satisfies NEMA 1 requirements.

Standard C2 box size: L = 4" W = 2-1/2" H = 2-1/8"

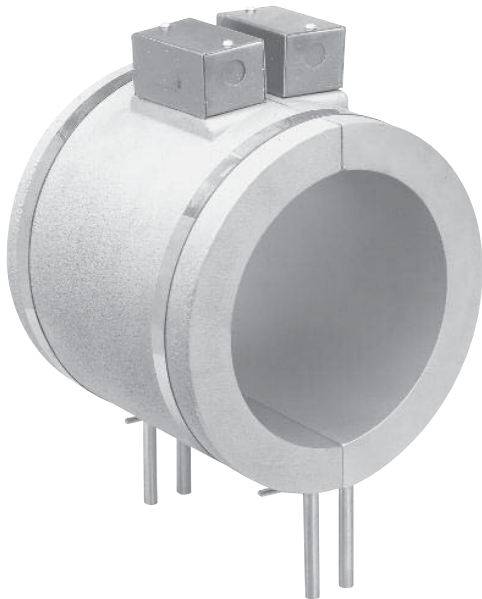

#### Terminal Protection for Both Heater Halves Type C7

Type C7 terminal boxes are made from rust-resistant sheet metal. The C7 base is fixed to the clamping straps. The box has two 7/8" diameter knockouts opposite each other for standard 1/2" BX connectors. The cover is removable, providing easy access to the screw terminals for electrical wiring.

To simplify installation, Cast-In Heaters fitted with boxes can be factory pre-wired with high temperature lead wire, protected with armor cable. If either one of these options is required, **specify terminal box type, lead wire and cable length**. Satisfies NEMA 1 requirements.

C7 Terminal Box Size varies with dimensions of casting.

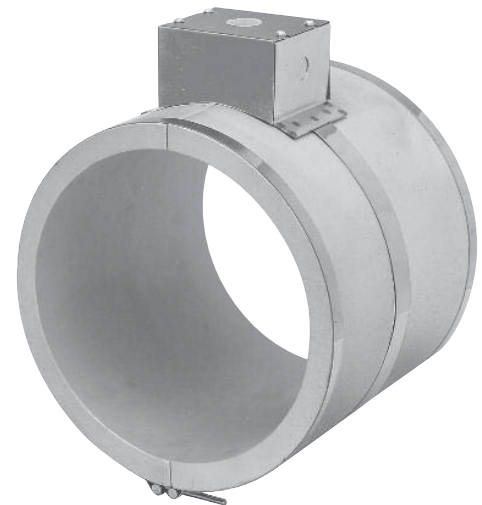

#### Quick-Disconnect High Temperature Cup and Box Assembly Type P2

Quick-Disconnect Cup assemblies provide the simplest and safest means for applying power to any type of Cast-In Heater installation. The box extends over the screw terminals on both Cast-In Band Heater halves. The combination of prewired cup and box assembly, along with factory prewired high temperature lead wire protected with armor cable, eliminates live exposed heater terminals and electrical wiring, protecting employees from electrical shock and the possibility of electrical shorts due to exposed wiring.

If prewired plugs are required, **specify length of lead wire and cable**.

Rated 250V maximum, 15 Amp maximum

Terminal Box Size varies with dimensions of casting.

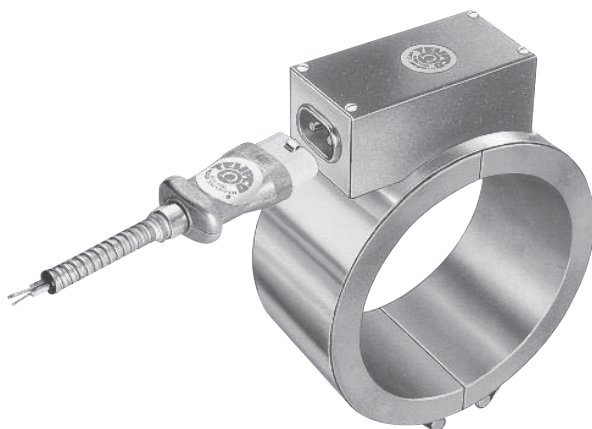



## Cast-In Heaters

### Electrical Termination Housings

#### Terminal Protection Boxes for Cast-In Heaters

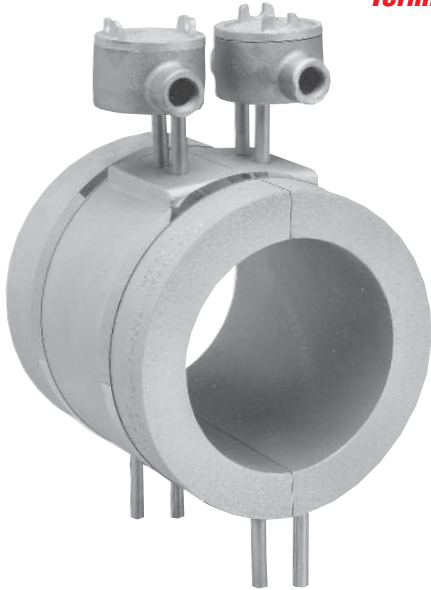

##### Type EP Explosion and Moisture Resistant Box

Cast iron explosion and moisture resistant boxes should be used in areas where the surrounding air may become contaminated with combustible gases or a high humidity level may exist. Installation requires one box per Cast-In Heater half and they are brazed to the tubular heater. The standard box has one 1/2" NPT hub.

**Optional:** Two hubs per box available. Cast-In Heater fitted with boxes can be factory prewired with high temperature lead wire, protected with special armor cable. If either of these options is required, please specify the following:

- Number of hubs
- Cable type
- Lead wire length
- Cable length

##### Type MPR Moisture Resistant Box

This design has a moisture resistant die cast aluminum box with a non-removable polyurethane gasket in the lid. Lid is secured with captive stainless steel screws. Body and lid are painted in basic industrial gray; interior contains copper ground screw. Box is mounted to a plate that is brazed to the element. Available in a wide variety of sizes.

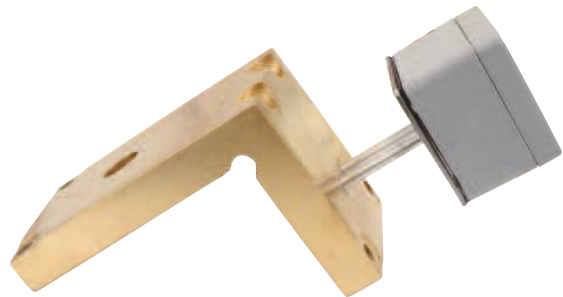

##### Type MR1 Moisture Resistant Box with Perforated Shield

This design incorporates the MPR housing style along with a perforated tube shielding unheated extensions of the tubular heating elements. This feature provides mechanical strength to the element extension and prevents overheating of the terminals, reducing possible premature failure from corrosion and oxidation.

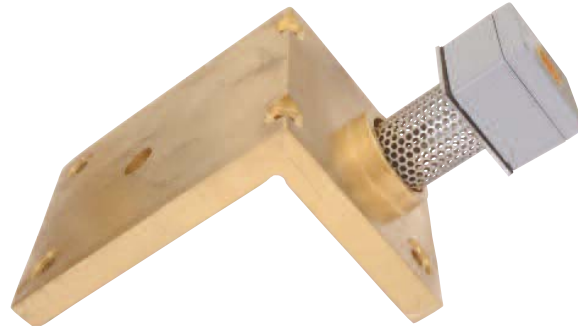

##### Type CB1

A Cast Aluminum Box is used to protect and secure lead wire terminations on narrower designs.

**Exposed electrical wiring on cast-in heater installations is a violation of Electrical Safety Codes including O.S.H.A.**

# Cast-In Heaters



## Liquid-Cooled

### Cast-In Band Heater Selection for Plastics Extrusion & Downstream Equipment

The Cast-In Band Heater listings on the following pages constitute a small segment of the thousands of Cast-In Band Heaters we have produced for plastics processing equipment. So that we may assist you in selecting the exact heater replacement for your machine, adhere to the following instructions:

1. Measure the O.D. of your barrel, which in turn will be the I.D. of the heater.
2. Measure the width of your heater.
3. Check the wattage and voltage rating per half or per segment. This information is normally stamped on the heater.
4. Establish heater cooling function, if any. If water cooled, measure length and diameter of cooling tube extensions. Cooling tube extensions are 3" long, and 1/2" x .049 O.D. wall thickness unless otherwise specified. If air cooled, Cast-In Band will have fins.
5. Check for special features such as: thermocouple clearance holes, drill and tapped holes, vent cutouts and terminal boxes.
6. There are two methods for securing a Cast-In Band Heater to a barrel: separate clamping straps or nut and bolt clamping.
7. Once you have established this information, proceed to match your heater description with one of our standard Cast-In Band Heaters. Starting with the I.D., read across the chart until you have a perfect match. Wattage can vary up to 15% either way with little or no effect to your process.

### Stock and Standard (Non-Stock) Liquid-Cooled Cast-In Band Heaters for Plastics Extrusion

I.D. in	O.D. in	Length in	Material	Watts Each Half	Volts Each Half	Phase	Termination Type	Terminal Box Type	Cooling Tube	Cooling Termination	Clamping	Cast-In Heater Part Number
2.25	4	17	Bronze	2000	480	1	R1	None	None	None	Strap	CBH08136
2.25	4.25	5	Bronze	1200	480	1	R1A	None	None	None	Strap	CBH08421
2.375	4.375	22	Brass	500	240	1	T7	EP	None	None	Bolt	CBH14001
2.5	4	6.25	Alum 319	750	208	1	F	None	None	None	Strap	CBH09711
2.75	4.75	2	Bronze	450	230	1	R2	None	None	None	Strap	CBH09227
3	4.5	2.5	Brass	350	120	1	E	None	None	None	Strap	CBH08847
3	4.75	4.5	Bronze	500	120	1	T7	None	None	None	Bolt	CBH05210
3	5	5.5	Alum 319	1000	230	1	T	None	None	None	Strap	CBH03097
3	5	5.5	Bronze	1000	230	1	T	None	None	None	Strap	CBH06726
3.125	4.625	3	Alum 319	400	220	1	R1	None	None	None	Strap	CBH06992
3.15	4.25	2	Brass	250	110	1	R1A	None	None	None	Strap	CBH08696
3.25	6.25	10	Alum 319	750	115	1	S	None	Single	None	Strap	CBH09445
3.5	6	17	Bronze	1250	208	1	R1	None	None	None	Strap	CBH04875
3.5	6.5	7.375	Alum 319	1500	230	1	S	None	Single	None	Strap	CBH10460
3.51	5.5	3.5	Alum 319	250	120	1	C4	None	None	None	Strap	CBH13189
3.8	6.55	3.75	Brass	1000	460	1	T7	EP	Single	HS	Strap	CBH12488

#### Key for Abbreviations found under the Termination Type Column

- |   |   |
|---|---|
| <b>C4</b> = Screw Terminal with Ceramic Cover | <b>R1A</b> = Stainless Steel Wire Overbraid                 |
| <b>E</b> = Right-Angle Lug                    | <b>R2</b> = Blockhead Screw Terminal                        |
| <b>F</b> = Flexible Lead Wire                 | <b>S</b> = Screw Terminal with Heavy Duty Ceramic Insulator |
| <b>R</b> = 90° Blockhead Screw Terminal       | <b>T</b> = Screw Terminal with Mica Insulator               |
| <b>R1</b> = Flexible Armor Cable              | <b>T7</b> = Screw Terminal with Ceramic Insulator           |

#### Key for Abbreviations found under the Terminal Box Type Column

- |  |  |
|--|--|
| <b>C2</b> = Standard Box                       | <b>EP</b> = Explosion and Moisture Resistant       |
| <b>C7</b> = Single Box over both Heater Halves | <b>MR1</b> = Moisture Proof with Perforated Shield |
| <b>CB1</b> = Cast Aluminum Box                 |  |

#### Key for Abbreviations found under the Cooling Termination Column

- |                              |   |
|------------------------------|---|
| <b>HS</b> = Hi-Seal Fittings | <b>RC</b> = Non-Exposed Cooling Tubes/Recessed NPT Fittings |
|------------------------------|---|



# Cast-In Heaters

## Liquid-Cooled

### Stock and Standard (Non-Stock) Liquid-Cooled Cast-In Band Heaters for Plastics Extrusion

Stock Items Are Shown In RED

I.D. in	O.D. in	Length in	Material	Watts Each Half	Volts Each Half	Phase	Termination Type	Terminal Box Type	Cooling Tube	Cooling Termination	Clamping	Cast-In Heater Part Number
3.99	5.25	4.312	Brass	600	240	1	R1	None	None	None	Strap	CBH04768
4	7	7.5	Alum 319	1000	115	1	T7	None	Single	None	Strap	CBH08859
4	7.5	7.5	Alum 319	1500	190	3	S	None	Single	RC	Strap	CBH06278
4.33	8.33	6.89	Bronze	600	230	1	C4	None	None	None	Bolt	CBH10533
4.331	5.831	6.89	Alum 319	600	230	1	C4	None	None	None	Bolt	CBH08244
4.331	8.331	6.89	Bronze	1300	230	1	C4	None	None	None	Bolt	CBH11210
4.5	6	9	Alum 356	1700	230	1	T7	None	None	None	Strap	CBH08756
4.5	7	4.375	Alum 319	810	240	1	E	None	Single	None	Strap	CBH01320
4.502	7	4.375	Bronze	810	190	1	R	None	Single	None	Strap	CBH06735
4.625	7.5	4	Bronze	1000	230	1	R1A	None	Single	None	Strap	CBH07254
4.75	6	24.25	Alum 319	N/A	N/A	N/A	N/A	None	Single	None	Strap	CBH09388
5.249	8.749	13.5	Alum 319	3750	230	3	S	None	Single	None	Strap	CBH05105
5.5	6.875	13.5	Alum 356	2250	230	1	T	None	None	None	Strap	CBH08088
5.5	6.875	18	Alum 356	3000	230	1	T	None	None	None	Strap	CBH08089
5.5	7.5	3.375	Bronze	1700	240	1	S	None	None	None	Strap	CBH04614
5.5	8	4	Alum 356	750	230	1	T	None	Single	None	Strap	CBH09056
5.5	8	8	Alum 356	1500	230	1	T	None	Single	None	Strap	CBH09278
5.5	8	13.5	Alum 319	2500	240	1	T	None	Single	None	Strap	CBH07489
5.5	8.75	5.5	Bronze	1050	200	1	R	None	Single	None	Strap	CBH06201
5.5	8.75	5.5	Alum 319	1050	230	1	R	None	Single	None	Strap	CBH01023
5.5	8.75	5.5	Bronze	1400	200	1	R	None	Single	None	Strap	CBH06202
5.5	9	10.5	Alum 319	3000	200	3	C4	None	Single	RC	Strap	CBH13928
6	8.5	6	Alum 356	2000	240	1	T7	C2	Single	None	Bolt	CBH14096
6.25	9.75	13.625	Alum 319	3000	230	1	R	None	Single	None	Strap	CBH01266
6.25	10	15.875	Alum 319	5000	230	1	S	None	Single	None	Bolt	CBH01726
6.299	9.45	2.56	Bronze	1250	240	1	T	MR1	Single	None	Bolt	CBH10318
6.3	8.656	14.563	Brass	5000	220	1	C4	None	None	None	Bolt	CBH06407
6.3	8.656	18.5	Brass	4500	220	1	C4	None	None	None	Bolt	CBH06409
6.3	9.813	15.75	Alum 319	5000	240	1	C4	None	Single	RC	Strap	CBH03737
6.5	8.5	4	Alum 319	900	230	1	S	None	Single	None	Strap	CBH03964
6.5	8.5	9	Alum 356	2000	230	1	T	None	Single	None	Strap	CBH09152
6.5	9	4	Alum 356	900	230	1	T	None	Single	None	Strap	CBH09049
6.5	9	8	Alum 356	1700	230	1	T	None	Single	None	Strap	CBH09050
6.5	9	11	Alum 356	2300	240	1	T	None	Single	None	Strap	CBH09129
6.5	9	18	Alum 356	3800	240	1	T	None	Single	None	Strap	CBH07310
6.5	9.75	7.75	Bronze	1800	190	1	R	None	Single	None	Strap	CBH05840
6.5	9.75	7.75	Alum 319	1800	230	1	R	None	Single	None	Strap	CBH01066
6.5	9.75	7.75	Bronze	2200	190	1	R	None	Single	None	Strap	CBH10749
6.5	9.75	7.75	Alum 319	2500	230	1	R	None	Single	None	Strap	CBH04401
6.5	10	8.5	Alum 319	1300	240	1	T7	None	Single	RC	Strap	CBH13353
6.5	10	11	Alum 319	1685	240	1	T7	None	Single	RC	Strap	CBH13396
6.5	10	11	Alum 356	2300	240	1	T7	None	Single	None	Bolt	CBH10742
6.5	10	18	Alum 319	2755	240	1	T7	None	Single	RC	Strap	CBH13341
6.5	10	18	Alum 356	3800	240	1	T7	None	Single	None	Bolt	CBH10741
6.5	10.5	3.281	Alum 319	1000	240	1	T7	EP	None	None	Bolt	CBH11254
6.625	10.125	6	Alum 319	1550	230	1	R	None	Single	None	Strap	CBH02138
6.625	10.125	8.5	Alum 319	2200	240	1	T	None	Single	None	Strap	CBH04393
6.635	9.875	17.5	Alum 319	4360	240	1	S	None	Single	None	Bolt	CBH06070



**Note: Made-to-Order Manufacturing:**

For sizes, ratings, terminations and/or features not listed, Tempco will manufacture a Cast-In Heater to your specifications. State quantity, watts, volts and full heater description with all the appropriate specifications and features required. See Ordering Information on page 3-63.

**Customer Assistance:**

If you have a special application requiring a custom manufactured Cast-In Band Heater or need assistance selecting one of our standard heaters for a new or existing installation, consult Thermal Devices with your requirements. We offer complete engineering services and support, working with you every step of the way to ensure customer satisfaction.

# Cast-In Heaters



## Liquid-Cooled

### Stock and Standard (Non-Stock) Liquid-Cooled Cast-In Band Heaters for Plastics Extrusion

Continued from previous page...

Stock Items Are Shown In RED

I.D. in	O.D. in	Length in	Material	Watts Each Half	Volts Each Half	Phase	Termination Type	Terminal Box Type	Cooling Tube	Cooling Termination	Clamping	Cast-In Heater Part Number
6.999	10.499	18	Alum 319	6000	230	3	S	None	Single	None	Strap	CBH05138
6.999	10.499	18	Alum 319	8000	230	3	S	None	Single	None	Strap	CBH09529
7.283	8.779	8.228	Alum 319	1300	230	1	C4	None	None	None	Bolt	CBH08232
7.283	9.659	8.228	Bronze	3700	230	1	C4	None	None	None	Bolt	CBH09953
7.5	10	4	Alum 356	900	230	1	T	None	Single	None	Strap	CBH09074
7.5	10	8	Alum 356	1700	230	1	T	None	Single	None	Strap	CBH09048
7.5	10	10	Alum 319	2150	240	1	T	None	Single	None	Strap	CBH07595
7.5	10	10	Alum 356	3225	240	1	T	None	Single	None	Strap	CBH09142
7.5	10	17.5	Alum 319	3750	240	1	T	None	Single	None	Strap	CBH12380
7.5	10	17.5	Alum 356	3750	240	1	T	None	Single	None	Strap	CBH09052
7.5	10	17.5	Alum 319	5625	240	1	T	None	Single	None	Strap	CBH12089
7.5	10	17.5	Alum 356	5625	240	1	T	None	Single	None	Strap	CBH09141
7.5	10.5	6	Alum 319	1500	230	1	C4	None	Single	None	Strap	CBH04607
7.5	10.5	10.25	Bronze	2085	200	1	S	C2	Single	None	Strap	CBH09904
7.5	10.5	10.25	Alum 319	2085	230	1	S	C2	Single	None	Strap	CBH01079
7.5	10.5	10.25	Alum 319	2085	230	1	S	C2	Dual	None	Strap	CBH02414
7.5	10.5	10.25	Bronze	3000	200	1	S	C2	Single	None	Strap	CBH09906
7.5	10.5	10.25	Alum 319	3000	230	1	S	C2	Single	None	Strap	CBH03778
7.5	11	10	Alum 319	1550	240	1	T7	None	Single	RC	Strap	CBH13274
7.5	11	10	Alum 356	2150	240	1	T7	None	Single	None	Bolt	CBH10743
7.5	11	10	Alum 356	3225	240	1	T7	None	Single	None	Bolt	CBH10768
7.5	11	16.5	Alum 319	5100	230	1	R	None	Single	None	Strap	CBH02351
7.5	11	16.5	Alum 319	5100	230	1	R	None	Single	None	Strap	CBH02878
7.5	11	16.5	Alum 319	5100	230	1	R	None	Single	RC	Strap	CBH06763
7.5	11	17.5	Alum 319	2650	240	1	T7	None	Single	RC	Strap	CBH13273
7.5	11	17.5	Alum 319	3750	240	1	R	C2	Single	None	Bolt	CBH10510
7.5	11	17.5	Alum 356	3750	240	1	T7	None	Single	None	Bolt	CBH10744
7.5	11	17.5	Alum 356	5625	240	1	S	None	Single	None	Bolt	CBH10686
7.5	11	18	Alum 319	5000	230	1	S	None	Single	None	Strap	CBH07153
7.56	11	22	Alum 319	6500	230	1	S	None	Single	None	Strap	CBH06168
7.56	11.125	18	Alum 319	4950	230	1	S	None	Single	None	Strap	CBH02240
7.625	11.125	12	Alum 319	2000	240	1	S	None	Single	None	Strap	CBH09378
7.625	11.125	14.375	Alum 319	3500	230	1	R	None	Single	None	Strap	CBH01026
7.625	11.125	14.375	Alum 319	3500	240	1	R	None	Single	None	Strap	CBH01094
7.625	11.125	14.375	Alum 319	3500	460	1	R	None	Single	None	Strap	CBH01206
7.625	11.125	18	Alum 319	3500	230	1	R	None	Single	None	Strap	CBH01140
7.625	11.125	18	Alum 319	3500	230	1	R	None	Single	None	Strap	CBH01143
7.625	11.125	18	Alum 319	3500	230	1	R	None	Dual	None	Strap	CBH07322
7.71	11.25	15	Alum 319	4600	220	1	S	None	Single	None	Bolt	CBH09595
8	11	11.5	Alum 319	2000	240	1	S	None	Single	RC	Strap	CBH06630
8	11	12.75	Alum 319	2875	240	1	S	None	Single	RC	Strap	CBH06647
8	11.5	9	Alum 319	1500	240	1	R	C2	Single	RC	Bolt	CBH08236
8.005	11.5	24.375	Alum 319	4500	480	1	C4	None	Single	HS	Strap	CBH09729
8.125	11.625	9	Alum 319	1500	240	1	T7	None	Single	RC	Strap	CBH13243
8.125	11.625	14	Alum 356	3275	240	3	T7	None	Single	None	Bolt	CBH10682
8.125	11.625	20	Alum 356	4675	240	3	T7	None	Single	None	Bolt	CBH10683
8.25	11.75	13	Alum 319	5500	460	1	R	None	Single	None	Strap	CBH02460
8.25	11.75	15.75	Alum 319	7000	460	1	R	None	Single	None	Strap	CBH02245

#### Key for Abbreviations found under the Termination Type Column

- C4** = Screw Terminal with Ceramic Cover
- E** = Right-Angle Lug
- F** = Flexible Lead Wire
- R** = 90° Blockhead Screw Terminal
- R1** = Flexible Armor Cable
- R1A** = Stainless Steel Wire Overbraid
- R2** = Blockhead Screw Terminal
- S** = Screw Terminal with Heavy Duty Ceramic Insulator
- T** = Screw Terminal with Mica Insulator
- T7** = Screw Terminal with Ceramic Insulator

#### Key for Abbreviations found under the Terminal Box Type Column

- C2** = Standard Box
- C7** = Single Box over both Heater Halves
- CB1** = Cast Aluminum Box
- EP** = Explosion and Moisture Resistant
- MR1** = Moisture Proof with Perforated Shield

#### Key for Abbreviations found under the Cooling Termination Column

- HS** = Hi-Seal Fittings
- RC** = Non-Exposed Cooling Tubes/Recessed NPT Fittings



# Cast-In Heaters

## Liquid-Cooled

### Stock and Standard (Non-Stock) Liquid-Cooled Cast-In Band Heaters for Plastics Extrusion

Stock Items Are Shown In **RED**

I.D. in	O.D. in	Length in	Material	Watts Each Half	Volts Each Half	Phase	Termination Type	Terminal Box Type	Cooling Tube	Cooling Termination	Clamping	Cast-In Heater Part Number
8.268	11.768	21.457	Alum 319	7500	220	3	C4	None	Single	RC	Strap	CBH03794
8.5	12	8.75	Alum 319	2900	460	1	T7	None	Single	None	Strap	CBH07043
8.5	12	8.75	Alum 319	3000	230	1	R	None	Single	None	Strap	CBH01444
8.51	11.75	18.25	Alum 319	5900	240	3	S	None	Single	None	Bolt	CBH06068
8.661	12.244	11.024	Alum 319	3400	230	1	R1A	None	Single	RC	Bolt	CBH11606
8.666	12.25	11.625	Alum 319	3400	240	1	R1A	None	Single	RC	Bolt	CBH07586
9	12.5	12.5	Alum 319	3750	240	1	C4	None	Single	RC	Bolt	CBH09779
9.05	12.55	15.98	Alum 319	5600	230	1	R1A	None	Single	RC	Bolt	CBH08396
9.055	12.563	16	Alum 319	5750	220	1	S	None	Single	None	Bolt	CBH09999
9.312	12.625	11	Alum 319	3750	230	1	C4	None	Dual	RC	Strap	CBH07949
9.312	12.625	11	Alum 319	3750	230	1	S	C2	Single	None	Strap	<b>CBH01108</b>
9.313	12.625	11	Alum 319	3750	230	1	R	None	Single	None	Strap	CBH01273
9.313	12.625	11	Alum 319	4950	230	1	S	C2	Single	None	Strap	<b>CBH01133</b>
9.5	12	12	Alum 319	3900	230	1	T7	None	Single	None	Strap	CBH12118
9.5	12	12	Alum 356	3900	230	1	T	None	Single	None	Strap	CBH09221
9.5	12	12	Bronze	3900	230	1	T	None	Single	None	Strap	CBH11491
9.5	12	16	Alum 356	5150	240	1	T	None	Single	None	Strap	CBH09126
9.5	12	24.5	Alum 356	7850	240	1	T	None	Single	None	Strap	CBH09127
9.5	12	24.5	Brass	11750	240	1	T7	None	Single	RC	Strap	CBH08350
9.5	13	8.5	Alum 319	4000	288	1	R	None	Single	RC	Bolt	CBH12533
9.5	13	11.5	Alum 319	2575	240	1	T7	None	Single	RC	Strap	CBH13354
9.5	13	13	Alum 319	5250	460	3	S	None	Single	None	Bolt	CBH08749
9.5	13	16	Alum 319	3580	240	1	T7	None	Single	RC	Strap	CBH13342
9.5	13	16	Alum 356	5150	240	3	T7	None	Single	None	Bolt	CBH10746
9.5	13	16	Alum 356	5150	240	1	T7	None	Single	None	Bolt	CBH10767
9.5	13	16	Alum 356	7750	240	1	T7	None	Single	None	Bolt	CBH10688
9.5	13	20.25	Alum 319	7500	240	1	C4	None	Single	RC	Bolt	CBH12958
9.5	13	24.5	Alum 319	5485	240	1	T7	None	Single	RC	Strap	CBH13371
9.5	13	24.5	Alum 356	7850	240	1	T7	None	Single	None	Bolt	CBH10689
9.5	13	24.5	Alum 356	7850	240	3	T7	None	Single	None	Bolt	CBH10745
9.5	13	24.5	Alum 356	11750	240	1	T7	None	Single	None	Bolt	CBH10690
9.5	13	27.75	Alum 319	12000	230	3	S	None	Single	None	Bolt	<b>CBH01528</b>
9.5	13	27.75	Alum 319	12000	230	3	S	None	Dual	None	Strap	CBH08104
9.75	12.75	24	Alum 319	9185	240	1	S	None	Single	None	Strap	<b>CBH02183</b>
9.75	13.25	9	Alum 319	3100	230	1	R	None	Single	None	Strap	CBH01532
9.75	13.25	11	Alum 319	3500	230	1	R	None	Single	None	Strap	CBH02461
9.75	13.25	11	Alum 319	3500	250	1	R	None	Single	None	Strap	CBH02692
9.75	13.25	11	Alum 319	4500	230	1	R	None	Single	RC	Strap	<b>CBH03873</b>
9.75	13.25	12	Alum 319	4500	230	1	R	None	Single	None	Strap	CBH01453
9.75	13.375	19.438	Alum 319	6000	230	1	R	None	Single	None	Strap	<b>CBH01144</b>
9.75	13.375	19.438	Alum 319	6000	230	1	S	None	Single	None	Strap	CBH01221
9.75	13.375	23.875	Alum 319	6000	230	1	R	None	Single	None	Strap	<b>CBH01077</b>
9.76	13	12.25	Alum 319	5000	240	3	S	None	Single	None	Bolt	<b>CBH06069</b>
9.842	12.188	13.375	Brass	3500	220	1	C4	None	None	None	Bolt	CBH06408
9.875	13	8.5	Alum 319	2000	240	1	E	None	Single	RC	Strap	CBH06648
9.875	13	12.25	Alum 319	4500	240	1	S	None	Single	RC	Strap	CBH06094
9.875	13.375	8.5	Alum 319	2000	240	1	R	C2	Single	RC	Bolt	CBH08955
10	13.5	12	Alum 319	6480	230	3	S	None	Single	None	Strap	CBH05102

**CONTINUED**

### Made-to-Order Manufacturing

For sizes, ratings, terminations and/or features not listed, Tempco will manufacture a Cast-In Heater to your specifications. State quantity, watts, volts and full heater description with all the appropriate specifications and features required. See Ordering Information on page 3-63.

### Customer Assistance

If you have a special application requiring a custom manufactured Cast-In Band Heater or need assistance selecting one of our standard heaters for a new or existing installation, consult Thermal Devices with your requirements. We offer complete engineering services and support, working with you every step of the way to ensure customer satisfaction.

# Cast-In Heaters



## Liquid-Cooled

### Stock and Standard (Non-Stock) Liquid-Cooled Cast-In Band Heaters for Plastics Extrusion

Continued from previous page...

Stock Items Are Shown In **RED**

I.D. in	O.D. in	Length in	Material	Watts Each Half	Volts Each Half	Phase	Termination Type	Terminal Box Type	Cooling Tube	Cooling Termination	Clamping	Cast-In Heater Part Number
10	13.5	12	Bronze	6480	230	3	S	None	Single	None	Strap	CBH08755
10	13.5	12	Alum 319	6480	240	3	S	None	Dual	RC	Strap	CBH07168
10	13.5	12	Alum 319	6480	290	3	S	None	Single	None	Strap	CBH05120
10.03	13.53	24.9	Alum 319	6000	480	1	C4	None	Single	RC	Strap	CBH06260
10.039	13.535	13	Alum 319	6000	220	3	C4	None	Single	RC	Strap	CBH04378
10.236	11.438	6.313	Alum 319	N/A	N/A	N/A	N/A	None	Single	None	Strap	CBH09288
10.5	14	10	Alum 319	2900	240	1	T7	None	Single	RC	Strap	CBH13499
10.5	14	21	Alum 356	11500	240	3	T7	None	Single	None	Bolt	CBH10685
10.625	12.625	10.5	Bronze	7000	480	3	T7	Rose	None	None	Strap	CBH07880
11.024	14.606	13.976	Alum 319	6050	230	1	R1A	None	Single	RC	Bolt	CBH08121
11.024	14.606	14.252	Alum 319	6250	230	1	R1A	None	Single	RC	Bolt	CBH11237
11.41	14.92	7.48	Alum 319	3313	230	1	R1A	None	Single	RC	Bolt	CBH08394
11.41	14.92	12.28	Alum 319	5425	230	1	R1A	None	Single	RC	Bolt	CBH08395
11.5	14.75	11.625	Alum 319	4700	230	1	S	C2	Single	None	Strap	<b>CBH01136</b>
12	15.5	11.5	Alum 319	4500	240	1	C4	None	Single	RC	Bolt	CBH09363
12.25	16.5	12.25	Alum 319	5500	230	1	S	None	Dual	None	Bolt	CBH06827
12.25	16.5	12.25	Alum 319	5500	230	1	S	None	Dual	RC	Bolt	CBH12665
12.5	16	11	Alum 319	7500	460	1	T7	C2	Single	RC	Strap	CBH10490
12.5	16	14	Alum 319	7500	460	1	T7	C2	Single	RC	Strap	CBH10489
12.5	16	14	Bronze	10000	460	1	S	None	Single	None	Strap	CBH02869
12.5	16	15	Alum 319	8750	240	1	R	None	Single	None	Strap	CBH01731
12.5	16	28	Alum 319	15000	480	3	S	None	Single	RC	Bolt	CBH07693
12.598	13.85	9.449	Alum 319	N/A	N/A	N/A	N/A	None	Single	None	Strap	CBH09287
12.598	16.181	16.653	Alum 319	8400	230	1	R1A	None	Single	RC	Bolt	CBH08122
12.996	16.5	13.75	Alum 319	6750	460	1	R	None	Single	None	Strap	CBH10840
13.5	17.25	26.5	Alum 319	10000	460	1	R	None	Single	HS	Strap	CBH01685
14	17.5	13.75	Alum 319	6250	240	1	C4	None	Single	RC	Bolt	CBH14211
14.567	18.189	17.874	Alum 319	10500	460	3	T7	Rose	Single	RC	Bolt	CBH10043
15	18.5	10	Alum 319	5500	240	1	S	None	Dual	None	Strap	CBH03477
15.354	17.354	4	Bronze	3000	240	1	R1A	CB1	None	None	Bolt	CBH08619
15.354	17.354	6	Bronze	3500	240	1	R1A	CB1	None	None	Bolt	CBH08618
15.75	17.75	2.5	Bronze	2800	240	1	T7	EP	None	None	Strap	CBH09753
16.142	18.142	7.875	Alum 319	6875	480	3	R1A	None	None	None	Strap	CBH10563
20.669	22.669	2	Alum 319	2500	220	1	S	C7	None	None	Strap	CBH04057
27	30	4	Alum 319	5000	480	1	E	Rose	None	None	Strap	CBH06807

### Made-to-Order Manufacturing

For sizes, ratings, terminations and/or features not listed, Tempco will manufacture a Cast-In Heater to your specifications. State quantity, watts, volts and full heater description with all the appropriate specifications and features required. See Ordering Information on page 3-63.

### Customer Assistance

If you have a special application requiring a custom manufactured Cast-In Band Heater or need assistance selecting one of our standard heaters for a new or existing installation, consult Thermal Devices with your requirements. We offer complete engineering services and support, working with you every step of the way to ensure customer satisfaction.

#### Key for Abbreviations found under the Termination Type Column

- C4** = Screw Terminal with Ceramic Cover
- E** = Right-Angle Lug
- F** = Flexible Lead Wire
- R** = 90° Blockhead Screw Terminal
- R1** = Flexible Armor Cable
- R1A** = Stainless Steel Wire Overbraid
- R2** = Blockhead Screw Terminal
- S** = Screw Terminal with Heavy Duty Ceramic Insulator
- T** = Screw Terminal with Mica Insulator
- T7** = Screw Terminal with Ceramic Insulator

#### Key for Abbreviations found under the Terminal Box Type Column

- C2** = Standard Box
- C7** = Single Box over both Heater Halves
- CB1** = Cast Aluminum Box
- EP** = Explosion and Moisture Resistant
- MR1** = Moisture Proof with Perforated Shield

#### Key for Abbreviations found under the Cooling Termination Column

- HS** = Hi-Seal Fittings
- RC** = Non-Exposed Cooling Tubes/Recessed NPT Fittings